

# the **WORLD** of **WIRELESS** from

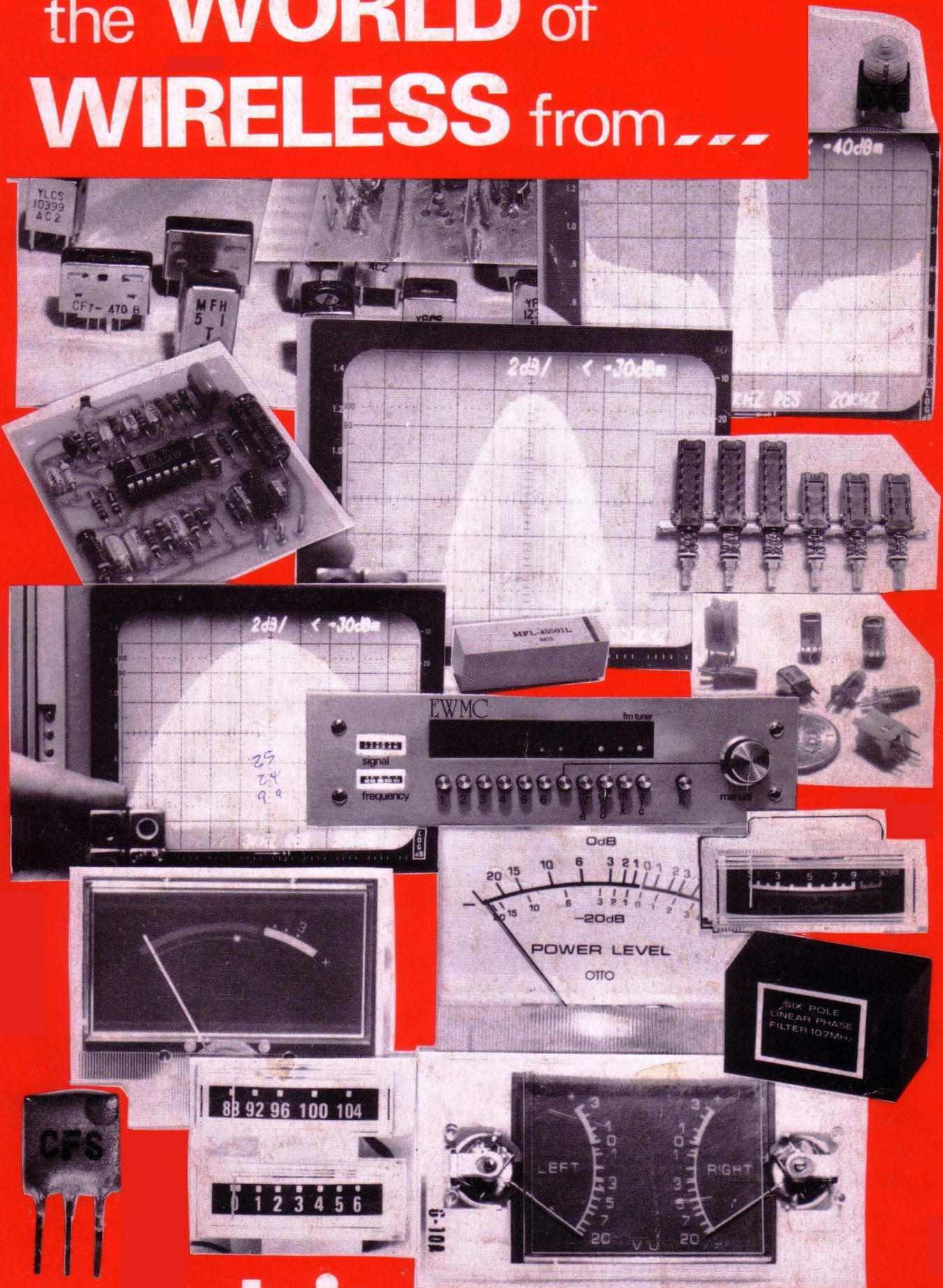

# ambit international 1978

Tecknowledgey: number 1

2 Gresham Road, Brentwood, Essex CM14 4HN (tel. 0277-216029)

## **1 Prices and Advertisements**

All prices published are offered as an invitation to purchase, and are thus not intended to form an irrevokable basis for a contract of sale (or purchase).

Every endeavour will be made to ensure that published prices will be maintained whenever possible, but please note that we reserve the right to alter published prices and specifications without notice. Advertisements in monthly publications are generally submitted 8 to 10 weeks in advance of publication, and are thus subject to occasional amendment by the time of publication.

## **2 Guarantee**

All goods are supplied in a condition 'fit for the purpose intended'. If any component or article supplied is proven to be faulty at the time of supply, then it will be either replaced, or repaired as necessary. Such is the nature of modern non-mechanical electronic components, that failure once satisfactory functioning has been achieved is extremely unlikely, unless affected by an external factor outside the maximum tolerances of the device concerned. All semiconductors supplied by Ambit have been thoroughly tested during the manufacturing process, and it is nearly impossible that any failure will occur in a correctly assembled application. Experience of production and statistical analysis of failures consistently reveals soldering, incorrect assembly and incorrect application of power, form over 95% of all equipment failure. (In non-mechanical systems).

A statistical analysis of IC failures reveals a failure rate, expressed as a percentage, of less than 0.05%, where no external cause of malfunction could be traced. Partial failures - ie excessive shot noise - are more common than a total failure to operate, and represent about 0.8% maximum.

Our warranty extends only to the cost of goods supplied, no consequential liability whatsoever can be accepted beyond this value, unless otherwise agreed and stated in writing by this company.

## **3 Accuracy of Information**

Whilst every effort is made to ensure the complete accuracy of all material published by Ambit, we cannot accept any liability, consequential or otherwise, for any errors that escape our attention. Persons noticing any errors are invited to advise us, in order that they may be investigated, and corrected where required.

## **4 VAT**

Value Added Tax is chargeable on all UK inland supplies. In most instances this is 12½%, but where a rate 8% is indicated, the price is marked with an asterisk \*.

## **5 Postage**

As a general rule, UK inland orders should include a postage and packing fee of 25p per order. Where additional money is required to cover the cost of carriage of bulky items, this will be indicated in the price list.

Overseas orders should include a minimum of 50p for postage, any extra than is required will be credited - or may be supplied in a number of components - such as BC108s - where we are advised to do so.

## **6 Supply times**

The vast majority of items in our catalogue will be available on an 'Ex-Stock' basis. Where this is the case, we endeavour to despatch the goods on the day the order is received. However, where pressure of work builds up, we occasionally require 48 hours for components - kits and modules may take longer, since these are built and tested on a batch principle, where production takes place, on average, in monthly cycles.

## **7 Enquiries and Suggestions**

We are always pleased to answer enquiries relating to products we supply. Please observe the following rules to ensure a satisfactory reply:

- a) Always include an SAE that will be large enough to take the information sought.
- b) Address enquiries to the Enquiry Service, NOT to 'The Manager' or 'Sales Department'
- c) Please make certain your enquiry cannot be answered by simple reference to the catalogue data.

## **8 Repair and technical services**

Never undertake a complex project unless you feel completely confident of your ability to sort out the minor problems concerning soldering, component location etc., that inevitably occur. (Unless you are very lucky.) Our repair service is a strictly non-profit making exercise in good customer relations, and we ask you to use it sparingly if it is to continue on the present basis. If possible, arrange to turn up in person with your problem(s) and we will try to fix it on the spot - and since well over 80% of all problems advised to us are simple soldering or assembly confusions, this is usually quite possible. Please do not return goods to us without previously contacting us with details of the problems, in case a written or telephonic diagnosis is possible.

The technical resources of the company are available for electronic design, prototype work, evaluation etc. The rates chargeable vary according to the nature of the project, but please anticipate a minimum of £4 -£5 per hour. This is still only one third of the rate paid by the Legal Aid scheme to solicitors, and represents excellent value in professional services ! Electronics engineers, and engineers in general are notoriously badly remunerated in this country - at present.

## **9 Callers**

During usual shopping hours, and quite frequently until 7,30pm (phone first, though!), we are open to callers. 2 Gresham Road is only 200 yards from Brentwood Station. (Eastern Region BR). Parking is available outside at ALL times for over 30 cars - on a restricted stay basis. Callers will also find our special offer boxes, and a number of items that have not found space in this catalogue.

## **10 Account Customers**

In brief, monthly account facilities are available to companies, schools, colleges, research organizations etc. The account terms are published separately, and are available on request. The processing charge per order is 50p, and the minimum order level for a/c purposes is £7.50 ex. VAT and processing charge.

Access orders are accepted from individuals, in either writing, or phone call form, or by personal call.

We may have got it all wrong, but we get the distinct feeling that there isn't a magazine on the market at the present, that pays much attention to wireless.

The more the term 'Wireless' appears in the title, the less wireless construction/discussion seems to appear dotted amongst the adverts for everything from fur coats to carpet.

Why? After all, electronics is almost exclusively derived from a history stuffed full of the stuff. Marconi marked the start of the era with his various experiments, and now the publications claiming to extol his brainchild cover just about everything *but* wireless!

And when wireless *does* make an appearance, it is as some historical feature, explaining the delights of bygone days, valves, and frequency allocations long since ceased.

This is probably beginning to sound a little bit cynical - particularly to a couple of publications who must be finding a tingling sensation in their ears - but it is aimed at being a serious investigation into the demise of the general art of wireless. Granted there are many companies engaged professionally in the production of exotic types of communication systems - but good old down-to-earth wireless has very little to do with satellite reception stations, fixed channel communications in the GHz bands and low power communications equipment that seem to use the same basic circuits from one design to the next.

Apart from the unimaginative approach of the broadcast and professional designers, the enthusiast has now fallen under the powerful spell of the "Black-box" syndrome. The Far East provides, and the enthusiast/amateur hangs up his imagination and skills to utter stereotype gibberish into square enclosures, bearing the mystic legends of the East, such as "Yaesu", "Trio", "Inoue" and others.

Asking a few enthusiasts why this should be so, a fairly predictable response emerges:

"I don't have the time to design my own circuits"  
"It's too much bother to shop around for the bits"

And in fact, the same basic reaction emerges from those questioned in the professional business of consumer and communications electronics. Everyone is smothered in all manner of literature explaining and endorsing the delights of microprocessors, CMOS, MOS op-amps, digital this, and digital that - but nothing very substantial ever appears to fire the imagination with wireless.

In the past 5 years or so, the technology of wireless - in terms of labour saving integration - has not been very much in evidence. Many ICs, with the notable exception of the famous CA3089E series, merely gathered up a few transistors in one package, and simply relied upon the mystique of the "IC" to mask the fact that the performance really wasn't cost effective with existing discrete approaches.

Early radio ICs were notoriously unstable in practise, and whilst the test circuit, surrounded with acres of earth plane was quite workable, the real applications with switches and other components - simply were not!

However, the past year has seen a few revelations, with a family of devices for consumer applications that employ the techniques normally associated with costly communications circuits. Four quadrant multiplier mixers are to be found in the VHF front end system, the TDA1062 - cheap AM/FM portable systems like the TDA1083, and the TDA1220. Single IC noise blanking is now feasible with the KB4423, for mono and stereo. And, of course, TOKO have responded with an increased range of low cost ceramic IF filters, mechanical filters and molded VHF coils.

The net result of this is that the time to design a wireless has been dramatically reduced. It may not be a purist's idea of circuit design, but running up a design with a TDA1062 for the VHF/HF input and converter stages, followed by the TDA1083 for the second conversion, if and audio stages comprises a complete radio, with a real cost effectiveness in terms of performance gains versus

the discrete alternatives. Fortunately, (for us), radio still requires coils and filters - and despite advances in SAW technology, these devices remain costly and burdened with insertion losses of 15dB+, making them an amusing little curiosity without any practical benefit - other than in some specific professional applications.

So although we haven't yet arrived at the instant radio - (just add water) - there has been a fairly major advance evident over the recent past. The second point raised, concerning the "shopping around" for parts, is one we are setting out to cover in this combination of catalogue and "magazine". Since we have always set out to be the wireless specialists in our product lines, we have tended to overlook the mundane things, like Rs and Cs.

With this issue, we aim to cover these areas too, again with values chosen for the types of circuits we promote, but ultimately we would like to be able to cover all eventualities. There is a danger, however, that our particular speciality may become lost and bogged down amidst all the triviality of 4k7 resistors - so we ask you to note the extra conditions concerning the purchase of passive components that appears on our price list.

To help make up your mind, we also offer an utterly unique service in reviewing radio products. We know it's unique, because we supply our reports back to the manufacturers for their analysis! If we appear biased, it's due to the fact that some manufacturers simply do not bother to answer letters or supply information about their product lines. (Are you receiving us there in Swindon, Plessey?)

**Which raises another point;** since in order to remain well informed, we ask anyone with a new product in radio - or simply anyone who has heard about something of interest - to let us have some details to include in our next review. We have no plans at present to launch into the style of a full blown, advertisement laden, glossy and technically insignificant publication - after the example of those run by a media more familiar with the promoting of cornflakes and soap powder. They make fine props for crooked chairs, and we suspect that engineers only look at them from a desire to make certain that they aren't missing anything startling and innovative.

**So** our aim is to produce some text of interest and benefit to that much neglected and under appreciated species known as the engineer. It may not necessarily be promotion as known and practised by those masters of the art of the greasy word and liquid lunch, but we have a feeling that sales must always start with the engineer and his basic approach to a design or specification. £400 worth of arty PR may send ripples of ecstasy down the copywriter's spine, but does it *really* get through to the engineer?

#### Things we are keen on in this issue include:

The amazing **one chip** communications receiver IC from Telefunken/Sprague and Hitachi - the TDA1083 series.

The superb RF/**balanced mixer/osc** for HF to VHF from Telefunken - the TDA1062.

The ULN2238, an 8DIL 800mW audio stage with no external components, and much wider voltage range than the LM380 - **operation down to 3v with low Iq.**

The TDA1220 from SGS, another one of the fine new breed of radio ICs with **balanced AM** stages.

TOKO's new LFY cascaded 4pole ceramic ladder filters, the KB4423 **noise eliminator IC** and much more.

TOKO's new **1-9v AM varicap triplet**, the KV1210, which promises better matching than the MVAM series, together with reduced cost and better Q in many applications.

The reference series tuner modules - now further in excess of broadcast standards than ever!

In fact, there is so much that is good and interesting in the new catalogue, that we warn you to lock up your cheque book and credit cards, or you may be tempted to try one of everything!



The Ambit range of low cost, ex-stock inductors includes a comprehensive range covering from 1uH to 120mH. A complete range in E24 series is available to special order, where a minimum order of 500 per value is requested. Sample quantities will be made available for pre-production purposes. Chokes listed here are held in quantity stocks, for immediate delivery. We anticipate that this selection should fill the majority of choke applications likely to arise.

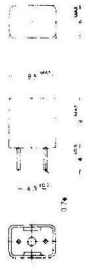

7BA

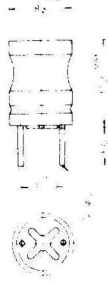

8RB

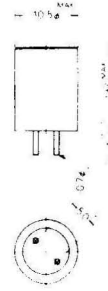

10RB

All dimensions shown in millimetres

TOKO Type		10RB 181LY-	Other	Inductance	Qu at Freq:		RΩ	I DC max. mA	Self resonant freq. MHz
7BA 144LY-	8RB 187LY-				MHz				
1R0				1uH	30	7.96	1.0	30	360
1R5				1.5uH	30	7.96	1.0	30	230
2R2				2.2uH	30	7.96	1.0	30	150
3R3				3.3uH	30	7.96	1.0	30	100
4R7				4.7uH	30	7.96	1.5	30	80
6R8				6.8uH	30	7.96	1.5	30	60
8R2				8.2uH	30	7.96	1.5	30	50
100				10uH	30	7.96	2.0	30	37
150				15uH	30	2.52	2.0	30	29
180				18uH	30	2.52	2.0	30	25
220				22uH	30	2.52	2.0	30	21
330				33uH	30	2.52	2.5	30	17
470				47uH	30	2.52	3.0	30	11.5
680				68uH	30	2.52	3.0	30	10
101				100uH	30	2.52	4.0	30	8
	101			100uH	80	.796	2.0	200	
	151			150uH	80	.796	2.0	200	
221				220uH	30	.796	6.0	30	5.5
	221			220uH	80	.796	3.0	200	
331				330uH	30	.796	6.0	30	4.5
	331			330uH	80	.796	4.0	200	
471				470uH	30	.796	9.0	30	4.0
	471			470uH	80	.796	4.0	200	
	681			680uH	80	.796	4.0	200	
751				750uH	30	.796	12.0	30	3.5
102				1mH	30	.796	14.0	30	3.0
	102			1mH	90	.252	6.0	150	
	152			1.5mH	90	.252	9.0	150	
	222			2.2mH	90	.252	13.0	100	
	472			4.7mH	90	.252	18.0	50	
		682		6.8mH	100	.1	7.5	35	
	103			10mH	100	.0796	40	40	
	153			15mH	100	.0796	60	40	
	223			22mH	100	.0796	80	30	
	333			33mH	100	.0796	80	30	
		333		33mH	100	.050	20	17	
		433		43mH	50	.050	100	20	.195
		513		51mH	100	.050	49	12	
		104		100mH	100	.050	63	9	
		124		120mH	100	.050	75	8	

Notes: The rated DC current is not necessarily an indication of the fusing value of DC current, but it is the DC current that affects the stated inductance by more than 20%. The above Qs are minimum values, the resistances quoted are maximum values.

#### Numbering system:

The chokes are stamped with the value, and tolerance, in the following form:

(144 H Y) 120 J (7BA indicated by prefix 144. Not stamped on choke)  
 H indicates ferrite type First two figures give value Third figure gives multiplier ie 10<sup>0</sup>  
 Y indicates 5mm pin spacing Final letter indicates tolerance J:5%, K:10%, M:20%. (All stock types 10% or better. Most are in fact 5% - 'J' types.)

[Many types of capacitor also employ a similar code - thus a ceramic plate capacitor marked '102' = 1nF]

We offer the world's largest range of signal inductors from TOKO. The types described here are selected from the vast range available, to represent the standard types commonly employed in the range 10kHz to 100MHz. Custom windings are available for orders of 1000 pieces or over, and if a suitable style is not shown here - please ask for further details.

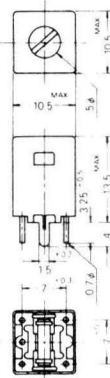
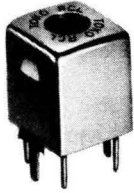
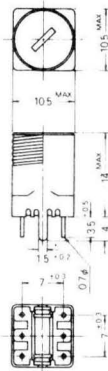
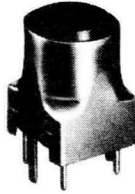
**10E & 10EZ****10P & 10PA**

These are the most commonly used style of coil. The 10E has a single bobbin winding, with cup core adjustment held in the base; the 10EZ is essentially identical, except that the cup core is held in plastic molding in the can. The 10E, 10EZ and 10P can be supplied with a single internal capacitor for IF applications. Up to three independent windings are possible, with a maximum pinout of 6.

The 10P and 10PA are available up to 36mH maximum inductance; the 10E is available with a maximum inductance of 2mH. Ferrites for Qs up to 180 are available, together with grades suitable for LF, MF, HF.

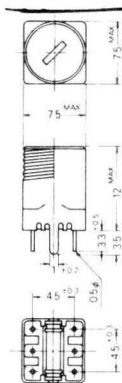
**7P (7E)**

The 7P, like the 10P in the larger format, is a single bobbin winding, with cup core adjustment held in the outer shielding can of the assembly. The 7E is essentially a scaled version of the 10E. Both the 7P and 7E are widely used in high density layouts for LF, MF, HF applications. A single internal capacitor may be included for IF applications, up to a maximum value of 180pF. Due to the miniaturized construction, the available Q of both types is generally some 10-20% lower than their 10mm format counterparts.

The overall dimensions of the 7P and 7E are identical.

The maximum inductance for the 7P style is 20mH, and 1mH for 7E.

Winding options as per 10E series.

7E not shown

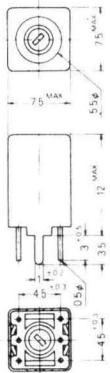
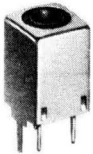
**7K (Sim. appearance to 7E)**

7K is an increasingly popular style used in custom applications for communications, radio control, and TV IFs. The basic area of operation is in the region 10MHz to 100MHz, with a maximum inductance of 10uH.

The construction differs from the 7P/7E, since the 7K uses a spiral former, with fixed cup core, and adjustable slug core, permitting fine adjustment, and excellent stability.

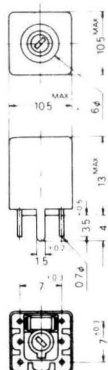
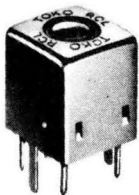
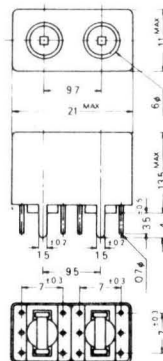
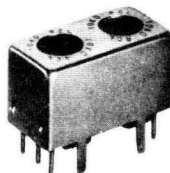
**10K****Double 10K (10WF)  
also double 10E (10WA)**

The 10K, and double 10K, are the standard choice for high stability FM and TV IFs. The construction is similar to the 7K: a spiral former, with fixed cup core, and adjustable slug. The maximum inductance for the single 10K is 50uH, with ferrites suitable for use from 2MHz to 100MHz. The double form is available with a maximum inductance of 25uH. In identical dimensions, a double 10E - the 10WA - is also available with a maximum inductance of 2mH per winding.

This compilation lists all the 'shelf standard types'. Other windings and configurations are available to special order, with a minimum order of 1000 pieces per item. A minimum order of 100 is occasionally possible at extra cost.

	Type no.	Use	Colour	Q	Int. CpF (or L)	Turns					Base No.
						1-2	2-3	1-3	4-6	other	
<b>10PA</b> for mpX	CAN1898HM	mpX	orange	50	7mH			396			1
	CAN1980BX	mpX	yellow	50	7mH	40		396		1-4:198½	5
	CAN1979A	mpX	white	50	11.75mH	257	257	514	257		3
	CAN1896HM	mpX	black	85	22mH	695					1
<b>10ME</b> Directly equiv. to above 10P	87BN134HM2	mpX	orange	55	7mH			349			1
	87BN135BX2	mpX	yellow	55	7mH	35	314	349	174		5
	87BN133ATO2	mpX	white	55	11.8mH	226	226	452	226		3
	87BN132HM2	mpX	black	100	22mH			618			1
	87BN1326HM	mpX	black	100	3.5mH	75					1
<b>10PA</b> misc	CAN1A350EK	LWrf	red	100	3.5mH	27	234	261	27		6
	CLNS30568Z	dolby	black	70	23mH			640			1
	CLNS30569Z	dolby	black	100	36mH			780			1
<b>10E/10EZ</b> for 455-470 kHz and MW/LW	YRCS11098AC2	1st amif	orange	90	180pF	140	25	165	4		6
	YRCS12374AC2	2nd if	yellow	90	180pF	127	38	165	6		6
	YRCS11100AC2	3rd if	black	140	180pF	104	36	140	20		6
	YHCS1A589R	am if	blue	150	180pF	15	125	140	6		6
	YHCS1A590R	am if	white	150	180pF	80	60	140	15		6
	YMCS2A740AAE	trap	brown	90	180pF			158			7
	YHCS17103DG	trap	white	140	180pF					2-6:149	8
	YMCS17104GO	if osc	yellow	110	180pF	98	67	165			2
	YHCS17105R2	3rd if	black	140	150pF*1	68	68	136	68		6
	YXNS6A139	lw pad	green	80	940uH					1-4:185	9
	YXNS6A140HM	lw pad	red	80	120uH			64			1
	YXRS18576AQ	mw osc	green	120	100uH			59	36		4
	YMRS80046N	mw osc	blue	70	158uH	2	79	81	9		6
	YMRS16726ZMS	mw osc	red	130	158uH	2	[3-4:83]			[5-6:9]	10
	YXRS17065	mw osc	red	80	180uH	3	77	80	12		6
	RWR331208N	mw rf	red	70	330uH	2	92	94	8		6
	RWOG6A6408	mw rf	red	80	360uH	95	3	98	12		6
	YXNS30450NK	mpX	blue	80	2mH				270		11
<b>10WA</b> double tuned	WFDC11115P	am if	pink	80	200pF	107				3-4:45	12
	WFDC11115S	am if	blue	80	200pF	[8-7:5, 8-6:152, 5-9:3]					
<b>7P</b> for 455-470 kHz IFTs	7MCS2197R	am if	blue	110	180pF	15	125	140	6		6
	7MCS2198R	am if	black	110	180pF	104	36	140	20		6
	7MCS2199DC	am if	white	110	180pF	80	60	140	15		6
	7MCS2194AAE	trap	brown	110	180pF			140			7
	<b>7E</b> 455-470kHz Radio control etc. IFTs.	LMC4100A	am if	yellow	105	150pF					
LMC4101A		am if	white	105	150pF						6
LMC4102A		am if	black	105	150pF						6
LMC4200A		am if	yellow	60	150pF	164	41	205	4		6
LMC4201A		am if	white	60	150pF	143	62	205	4		6
LMC4202A		am if	black	60	150pF	134	74	208	42		6
LLC238		am if	white	70	150pF	143	62	205	8		6
LLC4827		am if	yellow	70	150pF	126	79	205	10		6
LLC4828		am if	black	70	150pF	153	52	205	26		6
<b>10K</b> FM IFs, detectors 10.7MHz	KALS4520A	fm if	red	100	50pF	8	7	15	1		6
	KACS1506A	fm if	black	100	51pF	3	12	15	2		6
	KAC6184A	fm if	black	65	82pF	10	3	13	3		6
	TKAC34342	fm if	black	70	51pF			15	1		4
	TKAC34343	trap	black	70	51pF					3-4:15	13
	KACSK586HM	fm det	pink	100	82pF			12			1
	KAC8448PJQ	fm det	pink	65	68pF				11		14
	KAC8449SZ	fm det	blue	65	68pF	7	7	14	1		6
<b>10WF</b> double tuned	125LCS30035	fm if	pink	75	82pF			12			15
	125LCS30036	fm if	blue	75	82pF					6-8:13	15
<b>7P &amp; 7E</b> fm ifs 10.7MHz	119LC30099N	fm if	orange	90	82pF	8	2	10	4		6
	85FC4402SEJ	fm if	blue	100	100pF	6	6	12	1		3
<b>10K</b> Coils for shortwave	KANK3333R	sw1 rf	violet	60	45uH	14	41	55	4		6
	KANK3334R	sw2 rf	yellow	85	5.5uH	7	11	18	3		6
	KANK3335R	sw3 rf	pink	85	1.2uH	4	4	8	2		6
	KAN3426R	sw1 osc	white	65	38uH	3	48	51	4		6
	KANK3337R	sw2 osc	green	50	5uH	2	25	27	3		6
	KANK3428R	sw3 osc	blue	60	1.1uH	2	10	12	3		6
	K2027 (unshlded)	sw2 rf	none	90	9uH	3	25	28	6		3
	<b>10E</b> fm if	94AES30465N	fm if	brown	75	120pF	6	3	9	1	

\*1 To obtain a double tuned IF stage, couple pin 2 of the 589 to pin 6 of the 590 via 120pF. Input across pins 1&3 on the 590, output across pins 4&6 of the 590. Remember to ground pin 4 of the 590, and pin 1 of the 589.

## Base connections:

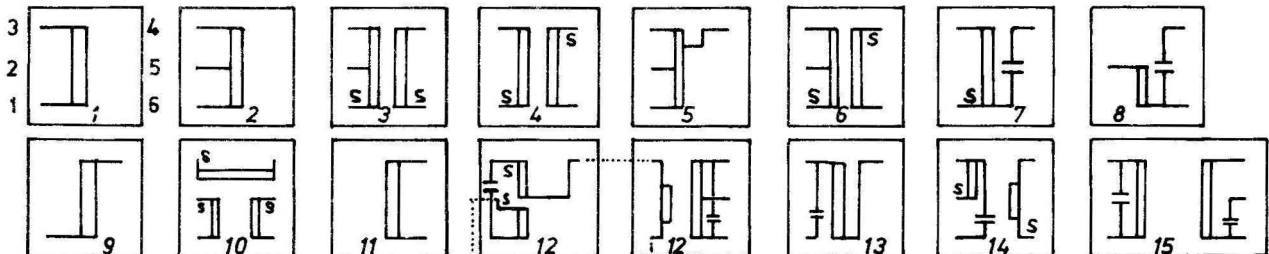

Signal coils Special functions: FM discriminators, TV IFs, and Misc.

Combinations of the IFs shown overleaf are used to perform functions of double tuned IFs, detectors etc. Listed here are the necessary interconnection details, together with the remaining 'standard' coils for TV.

**Double tuned AM IF stage**

Many combinations of standard AM IF can be coupled together to form a bandpass pair. Best symmetrical response will be achieved by coupling windings of equal impedances. Over coupling will lead to 'double hump' characteristics, and under coupling will simply loose signal unnecessarily - unless an exceptionally narrow bandwidth is required, in which case a ceramic or mechanical filter stage would probably be a better choice.

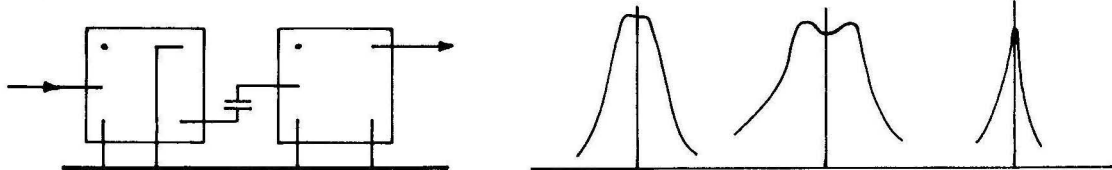

**FM ratio detectors**

The best all round detector for FM is still the basic ratio detector (in discrete systems, portables etc.) The incoming IF signal should be limited for best AM rejection.

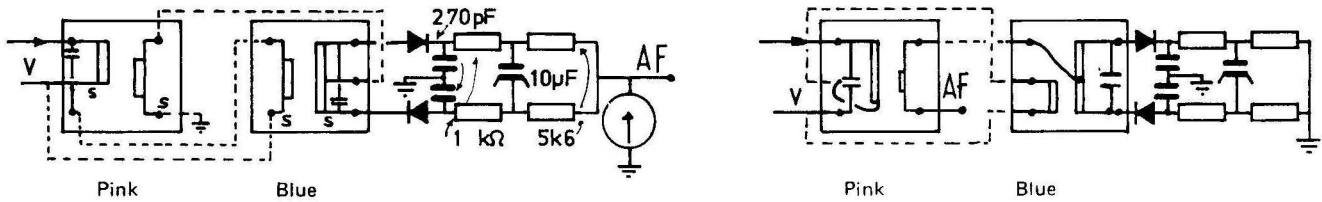

The standard 8448/8449 (10K) 10.7MHz (TKAC8448PJQ/KAC8449SZ)

Q:65

The standard 10516/10517 (10E) 10.7MHz (94ACS10516PJQ/94FCS10517STP2)

Q:80

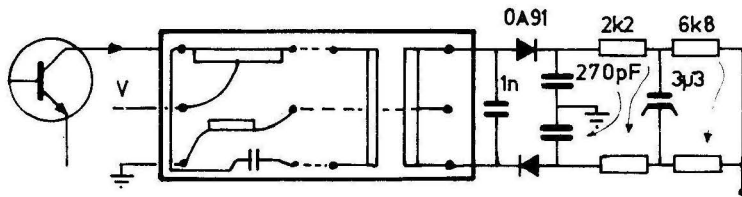

The circuits shown here illustrate the various configurations of the ratio detector. As you will see, it is possible to extract demodulated AF in two ways - and in both instances, a centre zero tuning meter may be driven from the same point. (Remember to use a high impedance meter, or series resistor in the case of a microammeter). Where the AF level is too high, this indicates that the Q of the unit is probably excessive, and should be damped by a resistor - as this will also improve linearity. The AF DC shift also accurately reflects the conditions necessary for an AFC function, though remember to check the AFC reference voltage on the tunerhead used, since it may be necessary to raise the reference voltage on the ratio-det. from its nominal of 0v on tune.

For 455/470kHz applications, the WRHC1A516/7

A Q of 100 means that for deviations greater than 7kHz, it may be desirable to reduce the audio output, by damping the tuned circuit with a resistor, until the correct level is achieved.

**TV coils: Video IF, colour sub carrier, and sound**





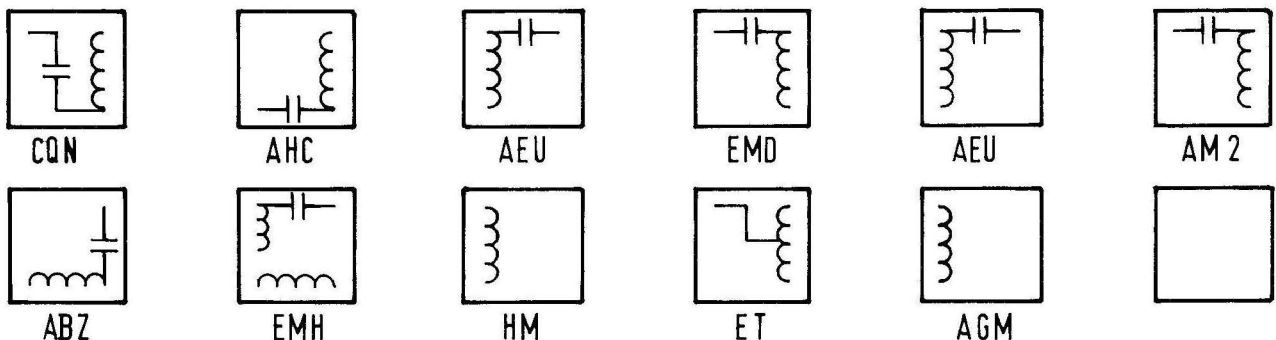





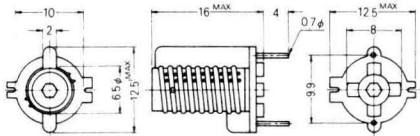

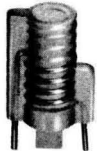
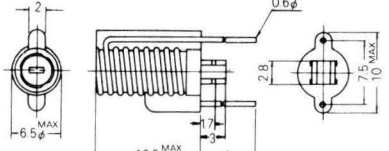

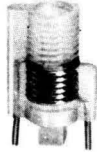
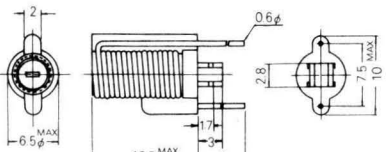
Coil type number	Colour	Tuning Capacitor	Frequency	Qu	Siemns type	Turns					
						1-3	2-3	1-3	1-6	4-6	3-4
TKXCA34732CQN	White	27pF internal	36MHz	85	D1N						9
KXCAK3347AHC	White	27pF internal	36MHz	85	D3N						9
TKXCAK3346AEU	White	39pF internal	41.4MHz	80	D4N			6			9
TKXCA34735EMD	White	82pF internal	31.9MHz	68	D5N						6
KXCAK3345AEU	White	27pF internal	31.9MHz	85	{D5N}	11					
KXCAK3344AM2	White	27pF internal	40.4MHz	80	D6N					7	
KXCAK2499ABZ	White	12pF internal	33.4MHz	75	D7N				16		
TXCA34909EMH	White	27pF internal	37MHz	65	D8/9		9		4		
MKANSK1731HM	Black	560pF external	6MHz	75	A1	8					
KANFK2495ET	---	1160pF external	4.43MHz	35	A2					10	5
BKANK3360AGM	Pink	1000pF external	5.5MHz	41	E2	7					

The above coil system is designed for applications in connection with most IC video amps., including TDA440, TDA4400, TDA4420 etc. It is anticipated that further additions to the range will be made available in due course. Also included are coils for TV sound (intercarrier) detection in connection with the TBA120 series.

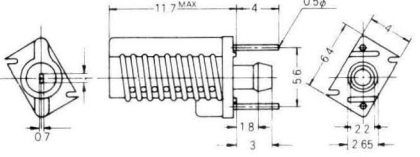

Rigid coils for VHF

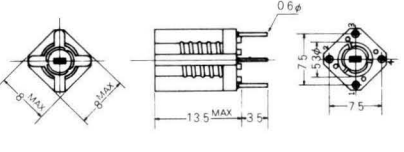
TOKO molded coil series

Type	Form	Dimensions (mm)	Tuning Method	Range MHz 1 MHz 10 MHz 100	L Range	Qu (typ.)	Tap & Sec. coil
S18					0.03μH ~ 0.4μH	100~200 at 58MHz 160~220 at 100MHz	Pri.; 1 tap; Sec.; None
MC115					0.03μH ~ 0.20μH	50~160 at 58MHz 110~180 at 100MHz	No tap & no Sec.
MC116					0.03μH ~ 0.48μH	50~140 at 58MHz 110~140 at 100MHz	No tap & no Sec.
MC108					0.03μH ~ 0.17μH	130 ~ 190 at 100MHz	Single Winding only; no tap
MC111					0.03μH ~ 0.50μH	50~140 at 58MHz 110~140 at 100MHz	Single Winding, 2 taps possible; Sec. Available

A full range of the S18 series coils is held in stock, and these are listed below. Of the other types, sample and small quantities are available from stock in styles, MC115, MC116 and MC111. An additional publication, entitled 'Molded coils for VHF' is available at 15p, and lists all standard types of these and others, together with full electrical and mechanical detail. Trimmers for the hexagonal ferrite cores, and slot types are available in molded nylon from stock.

Core Material	Ordering Code No.	Colour Code	Centre Frequency MHz	Tuning Range Capacitor pF	L (Ref) uH	Qu. Min.	Turns	TOKO PART NUMBER
A	301AN-0100	White	100	85 (3%)	0.03	100	1½	M-20160
L	-0200	Red	100	51 (3%)	0.05	100	2½	M-20002
U	-0300	Orange	100	32.7 (3%)	0.064	85	3½	M-20003
M	-0400	Yellow	100	31 (3%)	0.082	75	4½	M-20006
I	-0500	Green	100	25 (3%)	0.098	95	5½	M-20158
N	-0600	Blue	100	21 (1.5%)	0.12	90	6½	M-20004
I	-0700	Violet	100	17.8 (1.5%)	0.141	90	7½	M-20007
U	-0800	White	100	15 (1.5%)	0.168	90	8½	M-20156
F	301KN-0100	White	44	210 (6%)	0.06	120	1½	M-20162
E	-0200	Red	54	107 (6%)	0.08	68	2½	M-20161
R	-0300	Orange	58	60 (6%)	0.12	150	3½	M-25025
R	-0400	Yellow	75	27.7 (3%)	0.16	100	4½	M-20066
I	-0500	Green	65	27 (3%)	0.27	100	5½	M-20067
T	-0600	Blue	58	26 (1.5%)	0.27	100	6½	M-20068
E	-0700	Violet	58	21.8 (3%)	0.34	180	7½	M-20159
30-60 MHz	-0800	White	58	19 (1.5%)	0.40	155	8½	M-25232

The ceramic filters described here are designed for use in conjunction with one or more L/C tuned circuits at the preceding stage(s). Ceramic filters offer both high selectivity, combined with no adjustment requirements, and low cost. To obtain the best results, always terminate the filters as shown in the specification tables. Too high a termination resistance will result in narrowing, and peaking of the filter, and vice-versa. Please note the now obsolete SFG10.7 is replaced by two cascaded CFSE/SFE type filters for FM applications.

CFSE

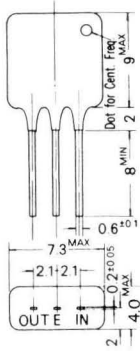

- A-10.70MHz ±30kHz
- B-10.67MHz ±30kHz
- C-10.73MHz ±30kHz
- D-10.64MHz ±30kHz
- E-10.76MHz ±30kHz

CFS  
10.7MHz

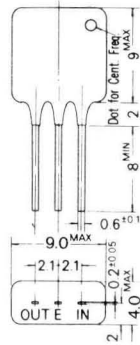

- A-10.70MHz ±35kHz
- B-10.67MHz ±35kHz
- C-10.73MHz ±35kHz
- D-10.64MHz ±35kHz
- E-10.76MHz ±35kHz

LFY

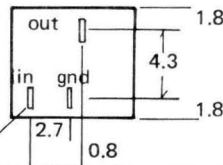
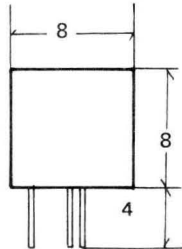

SFD

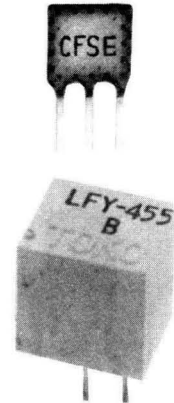
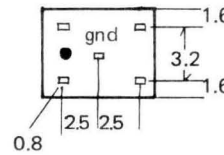
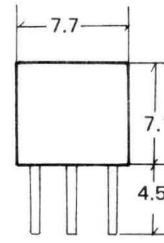

Specifications

Type	Centre frequency	Response	Loss	Input/output impedance	Spurious responses
CFSE / SFE107	see chart	-3dB: 280±50kHz -20dB: <600kHz	<6dB	330 ohms	>30dB [7-50MHz]
CFS107	see chart	-3dB: 300±50kHz -20dB: <650kHz	<6dB	330 ohms	>30dB [7-50MHz]
SFE6.0	6.0MHz ±70kHz	-3dB: >150kHz	<8dB	470 ohms	>25dB [5-8MHz]
LFY455B	455±1 kHz	-6dB: >6kHz -40dB: <9kHz	<6dB	2K ohms	
LFY455D	455±1.5kHz	-6dB: >12kHz -40dB: <25kHz	<6dB	2K ohms	
SFD455B	455±2kHz	-3dB: 4.5±1kHz	<9dB	3K ohms	
SFD470B	470±2kHz	-26dB: <10kHz			
SFD460B	460±2kHz	-20dB: <+10kHz			

Applications

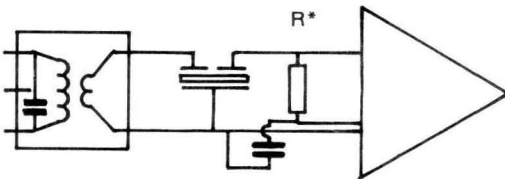

The CFSE filter is especially characterized for group delay constant with good stereo reception. The CFS is more suitable in mono and 'roofing' applications.

The CFS/SFE series

When used in FM/TV applications, always remember that the ceramic filter is quite transparent to local oscillator signals, at about 100MHz. For this reason, it is essential that one or more tuned circuits be used to prevent LO leakage from affecting the operation of the IF stages following the filters. Most IC amplifiers have an input loading stage resistor (R\*), and this should not necessarily be the value shown in the above table for the filter concerned, but it should take into account the input impedance of the IC itself. The uA753, for example, already uses a correctly terminated 330 ohm input, and requires no R.

The LFY

This recent development combines the highest density selectivity yet achieved. The input/output impedance is easily matched in semiconductor applications - but remember that some LC selectivity will also be required to tailor skirt responses.

Specially adapted types are available in quantity, for OEMs requiring variations of bandwidth, centre frequency etc.

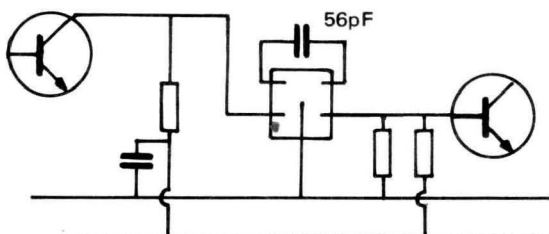
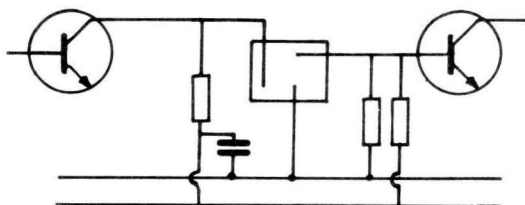

The SFD is a long established ceramic block filter for AM IFs. A 56pF external capacitor is required for neutralization, and coupling the two internal ceramic resonators.

Remember that simply adding stage after stage of selectivity, will not necessarily result in the desired bandpass response, due to the variations in centre frequency, accentuation of passband ripples, and general shrinkage effects. It is generally better to employ a single high selectivity filter block, such as the MFL, MFH etc.

**CFT**  
455 kHz

455 kHz  $\pm$  3.5 kHz

**CFU**  
455 kHz

455 kHz  $\pm$  3.5 kHz

**CFX**  
455 kHz

455 kHz  $\pm$  3.5 k

**CFM2 miniature mechanical filter unit**

Drawn actual size, the CFM2 is a recent development that offers high selectivity in a very small space. The unit makes an ideal interstage coupling, and may be cascaded

selectivity curves

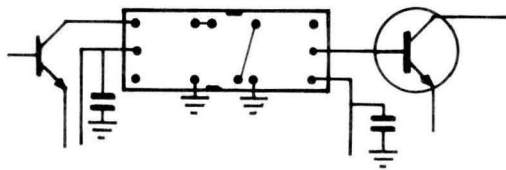

The CFT series connections

The CFT series of miniature ceramic filters, with a single ceramic element between an input, and an output matching transformer.

Centre frequency	CFT455B: 455kHz	CFT455C: 455kHz
-6dB bandwidth	8kHz	6kHz
Selectivity at $\pm$ 9kHz	>19dB	>28dB
Input impedance	300k	300k
Output impedance	5k/50pF	5k/50pF
Passband ripple	<1.5dB	<1.5dB

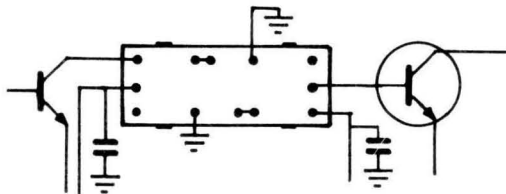

The CFU series connections

The CFU series are slightly scaled up versions of the CFT series, being based on 10mm matching transformers, as opposed to 7mm types.

Centre frequency	CFU050D: 470kHz
-6dB bandwidth	6kHz
Selectivity at $\pm$ 9kHz	>25dB
Input impedance	300k
Output impedance	5k/50pF
Passband ripple	<1.5dB

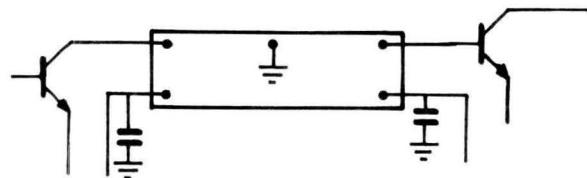

The CFX series connections

The CFX range are double ceramic filters, with input/output matching transformers. A single CFX exhibits the equivalent selectivity of 6 single tuned IFTs

Centre frequency	CFX014: 455kHz
-6dB bandwidth	5.5kHz
Selectivity at $\pm$ 9kHz	>40dB
Input impedance	50k
Output impedance	5k/50pF
Passband ripple	<1dB

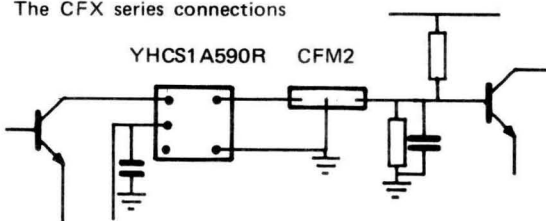

The CFM 2

The CFM2 is a recent development, based on TOKO's existing low cost mechanical filter technology. The unit is similar in size to the CFS FM types, and thus lends itself to miniaturized receiver applications. It may be readily cascaded (using matched units) to provide selectivity tailored to individual requirements.

Centre frequency	CFM455B: 455kHz
-6dB bandwidth	6kHz
Selectivity at $\pm$ 9kHz	>16dB [30dB with MT]
Input impedance	1k5 [150k with MT]
Output impedance	2k0
Insertion loss	<6dB
Ripple in passband	<6dB

**Important note:**

The filters described in this catalogue represent stock lines. For OEM requirements, many different centre frequencies (eg 460 - 468 - 462kHz) and different bandwidths are available to suit customer requirements. A minimum order quantity may apply, but samples are usually available within 2/3 weeks.

**General**

The HT series of mechanical filters are well established as the leading cost-effective solution to small size highly selective filters. They are suitable for use in all types of radio, from quality portable radio to CB and communication transceivers.

The filter is made from a high quality alloy "H" shaped resonator, encapsulated within a shield case that also includes the input matching transformer. The HT series are also supplied with an output matching transformer.

**Features**

Flexible termination impedances, combined with trimmable input/output circuits enable optimum performance to be achieved at all times.

Established quality and reliability, complemented by the range of TOKO coils and signal inductors.

**Physical dimensions in mm:**

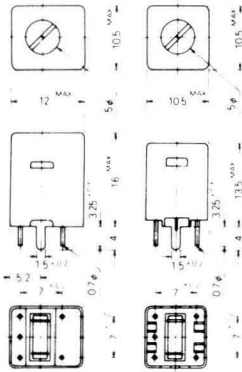

**Base connections:**

**MFH-T**

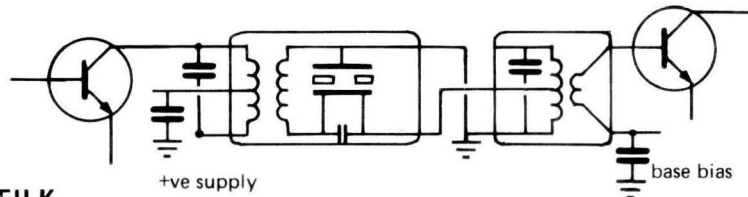

**MFH-K**

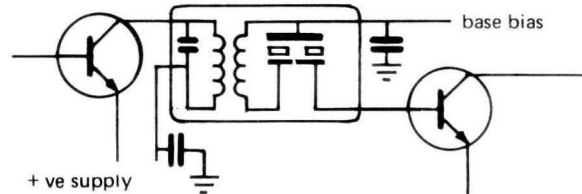

**Test circuits**

$$\text{Insertion loss} = \frac{10 \log R2 \left[ \frac{E1}{E2} \right]^2}{4R1}$$

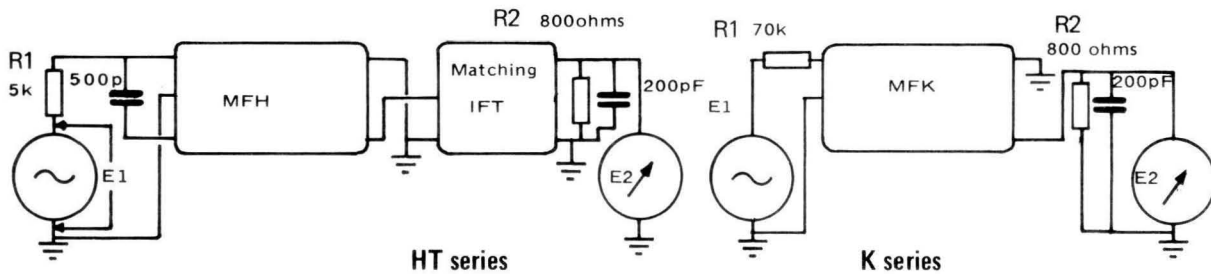

**Response curves:**

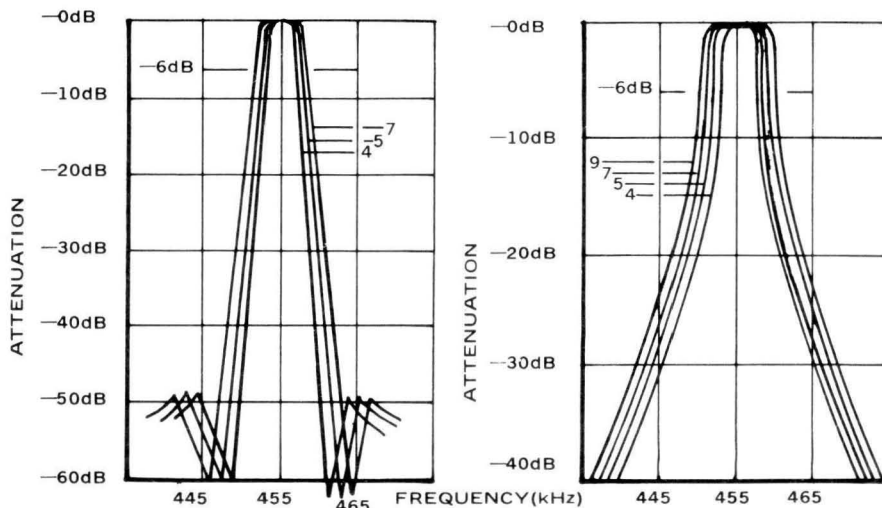

**Specifications of HT and HK series:**

Type	Centre frequency	Bandwidth (-6dB)	Selectivity	Ripple in passband
MFH41T	455±1kHz	4 (+1 -0.5) kHz	> 40dB	<1dB
MFH51T	..	5 (+1 -0.5) kHz	(±8 kHz)	<1dB
MFH71T	..	7 (±1) kHz	>22dB(±6kHz)	<1dB
MFH40K	..	4 (+1 -0.5) kHz	>20dB(±6kHz)	<1dB
MFH50K	..	5 (+1 -0.5) kHz	>25dB(±10kHz)	<1dB
MFH70K	..	7 (±1) kHz	>22dB(±10kHz)	<1dB
MFH90K	..	9 (±1) kHz		

**General**

The MFL mechanical filter has been developed as a low cost SSB filter in both generator, and receiver applications. It is constructed from 6 mechanical elements, and housed in a PC mounting plastic case.

**Features**

The MFL combines high performance, an extremely smooth passband and small size at a highly economical price. Input and output matching transformers ensure easy matching, with impedances that are commonly associated with silicon transistor or IC circuitry. It thus provides an unprecedented combination of price and performance for the communications, CB and amateur markets.

**Dimensions in mm:**

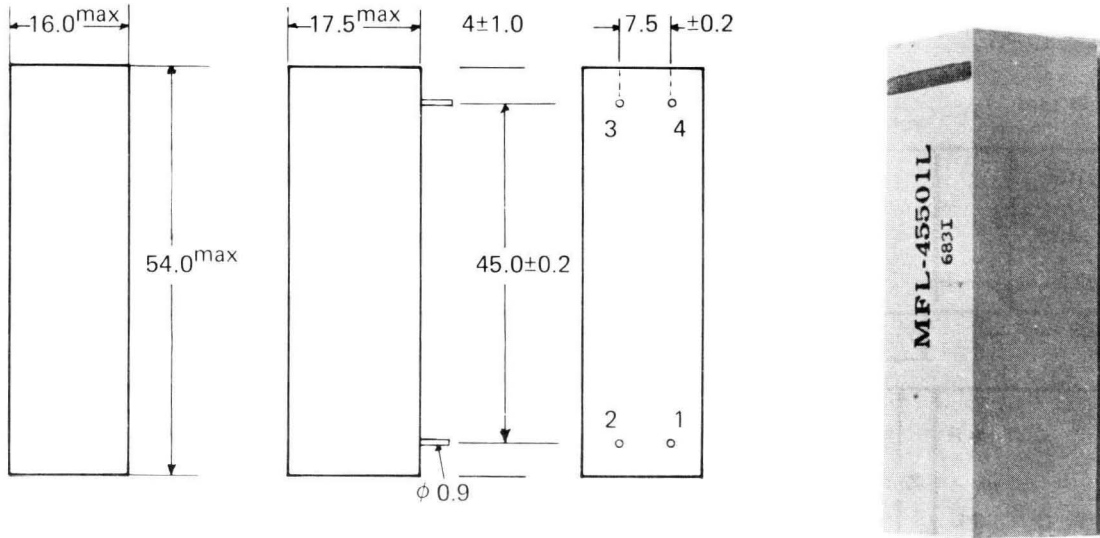

**Characteristic curve with matching transformer**

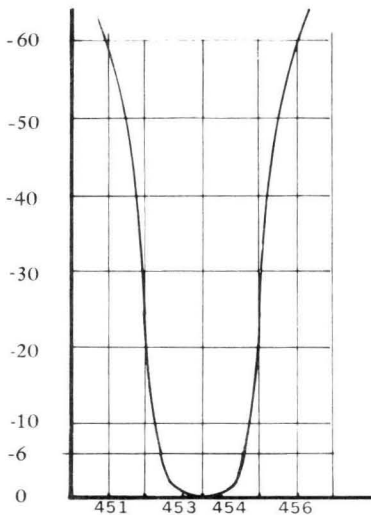

**Standard connection with matching transformer**

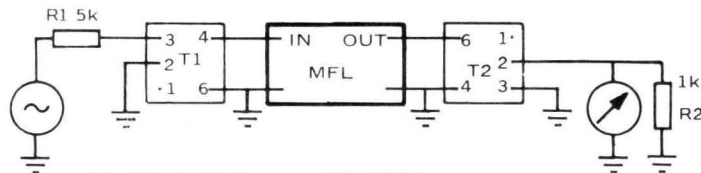

T1: RMC41996N, T2: RMC4197N  

$$\text{Insertion loss (dB)} = 10 \log \frac{R2 [E1]^2}{4R1 [E2]}$$

**without matching transformer**

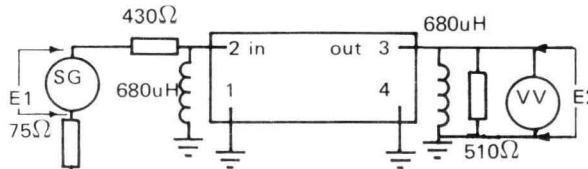

$$\text{Insertion loss (dB)} = 20 \log \frac{E1}{2E2}$$
  
 (E1 unloaded value)

**Electrical specification:**

Parameter	Minimum	Typical	Maximum	Notes
Centre Frequency	453.20kHz	453.50kHz	453.80kHz	for 455kHz carrier
Bandwidth at -6dB	1.8 kHz	2.1 kHz		
Attenuation at 455kHz	18dB	26dB		Without T1 and T2 With T1 and T2
450kHz	60dB	68dB		
456kHz	45dB	58dB		
Passband ripple		1dB	2dB	
Insertion loss		10dB	12dB	
Input/output impedance		500Ω 5k/1k		

Pilot tone and bias trap filters TOKO 190/170BLR series

Despite attempts to produce ICs with no 19/38kHz leakthrough in stereo multiplex decoder systems, the absence of a purpose made twin notch and low pass filter, such as the 170/190 BLR series, is still the prime cause of trouble in many recording applications. Too much pilot leakage to the amplifier will also lead to annoying intermodulation problems, and in some instances, an unexplained amplifier and loudspeaker overload. Note that these filters must be resistively terminated to avoid ripple and unwanted peaking in the passband. The 170 series offer twin stereo 19 & 38kHz notches, plus a general low pass function above 15kHz. The 190 series are single channel units, also available as combined MPX and trap filters for use in Dolby processor circuits.

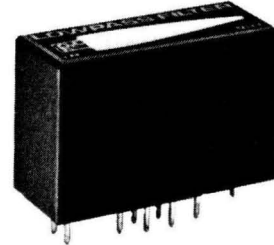
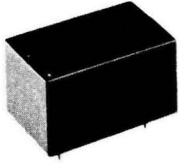

Dimensions in mm

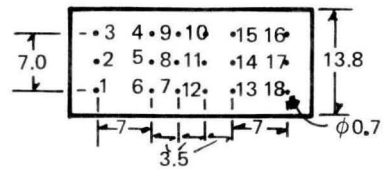
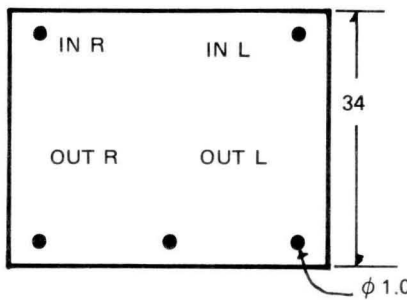
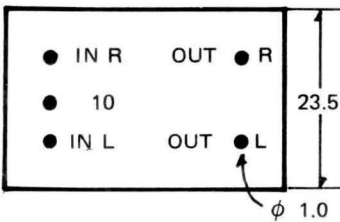
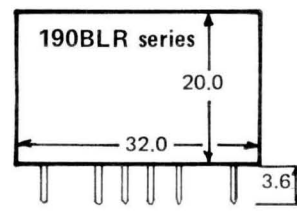
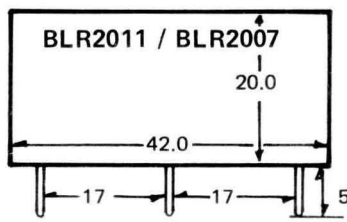
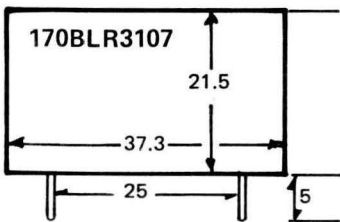

a: Dolby out, b: Dolby in

Base connections

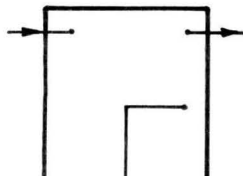
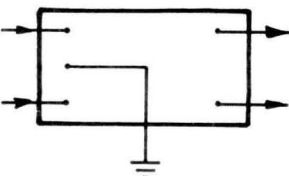

Configuration of MPX filters

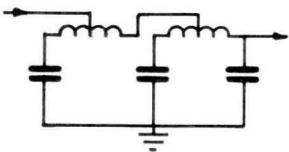

-trap filters

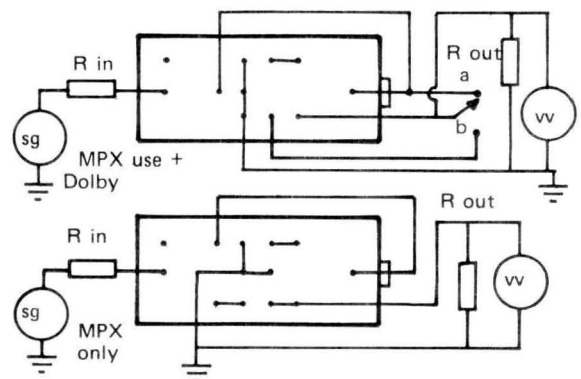
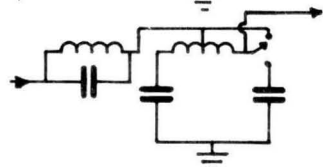

TOKO type	Use	Attenuation relative to 0dB/400Hz (15kHz max, others min.)							Impedance	
		15kHz	19kHz	38kHz	23kHz	60kHz	85kHz	100kHz	in	out
190BLR3107N	stereo mpX	1.2	26	50					4k7	4k7
2x190BLR3107N	cascaded	1.2	45	75	44	65	63	63	4k7	4k7
BLR2007	stereo mpX	3	20	55					3k0	3k0
BLR2011	stereo mpX	1.0	30	30					1k1	4k7
190BLR3152	mpX	1.2	30	52					4k7	4k7
190BLR3154	mpX	2.0	30	60					4k7	3k0
190BLR3157	mpX	3.0	37	60					4k7	3k0
190BLR3172	Dolby	1.0	32	20	14		65		3k3	5k6
190BLR3177	Dolby	1.0	32	20	14			68	3k3	5k6
190BLR3180	Dolby	1.0	32	20	14	62			3k3	5k6
BLR3107 modified	mpX	0.1	21	61					4k7*	4k7

\* Fed from 2k4 resistive into 2k2 with 2.2nF in parallel on input side only. Standard 170BLR3107N used.

The sudden upsurge in 'linear phase filters' may confuse some of you who had just been educated to imagine that ceramic IF filters were the word in FM IF selectivity. Especially since most linear phase filter characteristics appear somewhat wider than the ceramic filters they are replacing.

The reason is twofold, basically the linear phase filter with its flat group delay is less likely to distort the extremes of the complex multiplex transmission, which requires a passband of some 200 to 300kHz for best results. Otherwise, the trouble will manifest itself in variable group delays, which will upset the relative phases of the pilot tone, the 38kHz sub carrier and its associated sidebands, resulting in a general lowering of the maximum separation and an increase in THD at high frequencies. The wide bandwidth is thus desirable, but in some instances where channel separation is inadequate, it will lead to 'birdies' due to the mixing effects of adjacent carriers and pilot tones. The designer must therefore anticipate these problems, and include a 55kHz low pass filter between detector and decoder. Secondly, the linear phase filter has a reliable and accurate centre frequency, facilitating easy applications with all forms of frequency counter display, and synthesizer. Modern ceramic filters of the CFSE family are almost as good

in most major parameters, and possess a far lower insertion loss - but all types of ceramic filter require an LC tuned circuit to precede their application, since an entirely ceramic filter would not possess adequate 'out-of-band' attenuation. Finally, the long term stability of the LC linear phase characteristics of its LC construction will tend to track those in the LC detector stages.

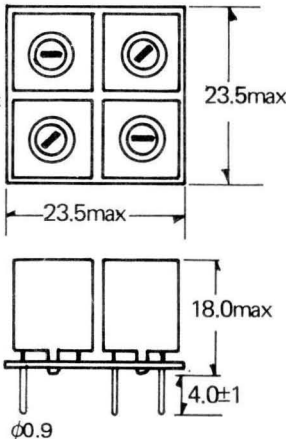
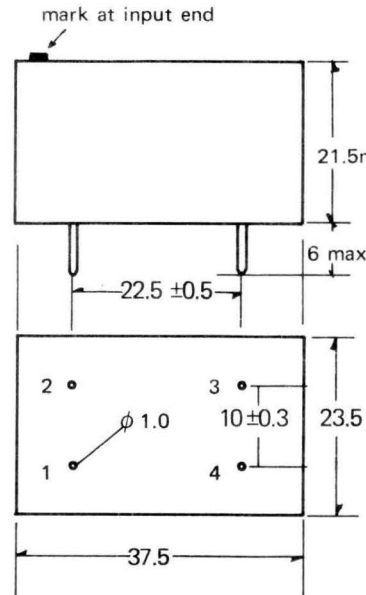
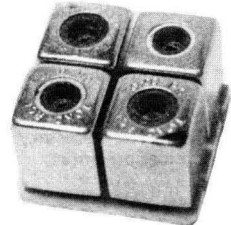
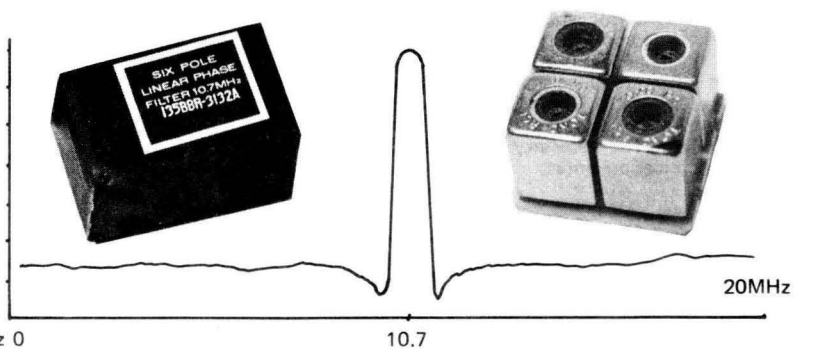
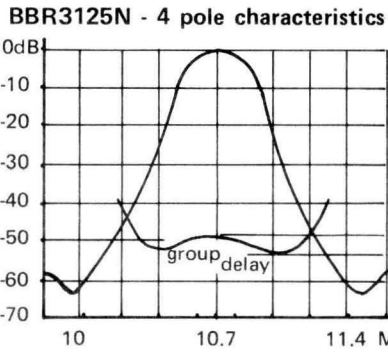
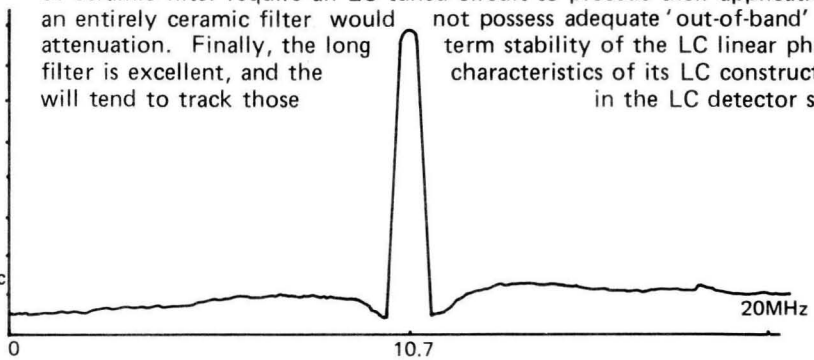
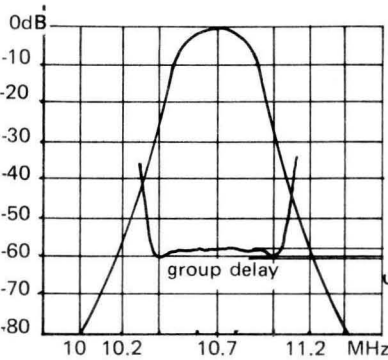

- 1 Ground
- 2 Input
- 3 ground
- 4 Output

NB A DC path exists between input and output

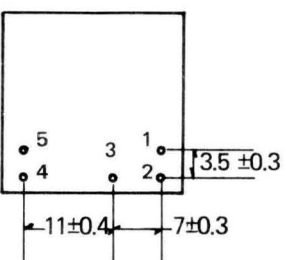

- 1 Signal in
- 2 Signal earth
- 3 Earth
- 4 Output earth
- 5 Output signal

Specifications			
Type	BBR: -3dB BW	Group delay	Impedance
			in out
3132A	240kHz	>0.5uSec	1kΩ 560Ω
3125N	230kHz	>0.5uSec	330Ω 330Ω

Notes:  
 The group delay is given for the following bandwidths  
 3132A: ± 175kHz 3125N: ± 150kHz  
 The insertion loss, for a correctly terminated filter :  
 3132A: max. 16dB, typically 13dB  
 3125N: max. 14dB, typically 10dB

Test circuit notes

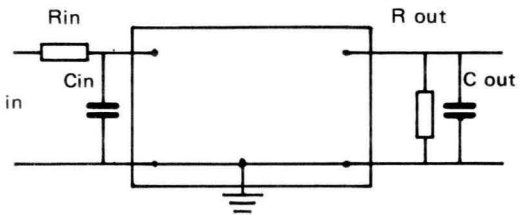

The input impedances given in the table above do not include the additional capacity required for a perfect match. The additional capacity must take into account all circuit strays.

- BBR3132A Cin / Cout = 10pF
- BBR3125N Cin = 5pF Cout = 30pF

**The HA1137W**

There has been a lot written about the new CA3189E recently, but here is largely the same device - available since 1975 from Ambit ! The major feature of the CA3189E is the new deviation muting system, and the very same system is employed in the HA1137W, in fact the HA1137W is a direct pin replacement for the CA3089E series, and may be used in many instances to uprate existing CA3089E circuits by simple substitution. This is not to say that the CA3189E does not have any advantages, because certain aspects of the new design are distinctly improved, permitting easier application due to the lower frequency response of the IF circuits of the CA3189E. However, we will continue to offer all three variations of the CA3089E, since each will continue to appear in published circuits for years to come - and due to the flexibility of application possibilities, each has relative merits in certain designs.

The overall muting performance of the HA1137W is still probably the best, and we are pleased to announce a second source of this particular design from Kyodo. The choice of the quadrature components is crucial, but more information relating to applications can be read in our section on the modules which employ this family of FM devices. It is interesting to note that the CA3089E family is the most widely used specific function linear IC ever designed, and we can state quite categorically that Ambit is more familiar with all the variations and their application, than other company in the world. We will be supplying further information in the data/magazine feature section of this, and subsequent catalogues. The CA3089E series is superior to virtually all other FM IF devices yet announced.

**Typical dynamic characteristics**

Current consumption	mute on	32mA
input limiting voltage	-3dB limiting	12uV
recovered audio voltage	30% mod only	100mVrms
THD	30% mod	0.1%
S/N ratio	30% mod	60dB
AM rejection	30% mod	45dB
Muting sensitivity	V12=1.4	18uV
Muting bandwidth	15k*	95kHz
Muting attenuation	V5=2	60dB

\*resistor between pins 7 and 10

Note these readings are related to a practical deviation of 22.5kHz, and should not be directly compared with figures obtained with 75kHz deviation.

For application at narrow deviation, the quadrature feed choke between pins 8 & 9 should be increased to 120uH and the damping resistor from pins 9 & 10 should be omitted.

Further notes on the CA3089E etc. are available when the device is purchased. Most application notes are applicable to all members of the family ie 3089/1137/3189.

Please note that at lower frequencies of operation, the internal coupling capacitors for the AGC and mute functions may not be sufficiently large to permit correct operation of these aspects of the IC. The necessary additional circuitry is included in our application notes.

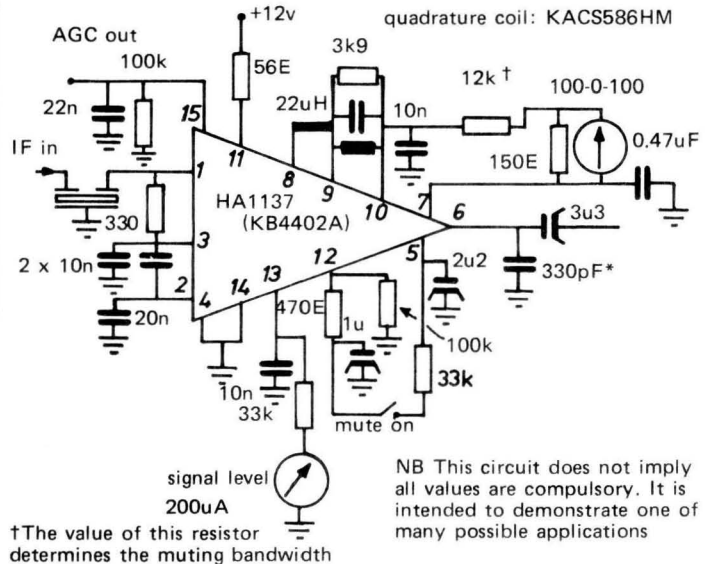

NB This circuit does not imply all values are compulsory. It is intended to demonstrate one of many possible applications

**The HA1197**

AM radio design has been more static than FM design over the past few years. Early attempts at combining all AM functions into one IC were distinctly unfavourable - the TAD100 and TAD110 were notoriously difficult to work with. Even the more popular device from SGS, the TBA651, is not recommended for the beginner, since layout and stability considerations require much patient experiment to optimize. But moreover, most AM ICs offer little advantage over a discrete circuit, using three or four transistors.

The HA1197 is the first significant advance in AM radio design, since the exceptional AGC and low THD are not readily duplicated in discrete form. The IC also feeds a signal level meter, which provides a really useful reading when checking relative signal strengths. Despite the internal detector, it is possible to use the device with an IF output, by simply omitting the RF decoupling capacitor at the audio output stage. (C107 at pin 12). This point must be well located away from the IF inputs, since the high level of IF signal can readily cause feedback instability - always feed this IF into a low impedance to keep the RF voltage low. The IF signal is rectified at pin 12, but a single IFT will regenerate a full IF signal for NBFM/SSB demodulation in a subsequent stage.

**Typical dynamic characteristics**

Current consumption	Vcc12v	15mA
Signal to noise ratio	74dBu in	53dB
	34dBu ..	33.5dB
THD	74dBu 90%mod	0.8%
	100dBu 30%mod	0.4%
AGC range	10dB AF shift	75dB
Output voltage	74dBu in	250mV
Meter current	100dBu in	240uA

All modulation levels taken as 30%, except where stated

The HA1197 will work with its internal oscillator up to 60 or 70MHz - but it is not recommended to employ the internal oscillator much above 14MHz, if best stability is to be obtained. With an external oscillator, applications at 50MHz have worked very well, offering an input sensitivity of 4-10uV to the IC pin 2. When injecting an external oscillator, a level of some 250mV p-p injected at pin 6 is recommended. Alternatively, a higher level oscillation injected into pin 7, with the RF stage coupled into pin 6, instead of pin 7.

The resistor in series with the IF admittor circuit (pins 9 & 13), may be reduced progressively - or replaced by a preset of 500 ohms, and this will bring up the level of IF gain - probably to the point of instability. This is not a suitable point for a panel control.

All types of TOKO filters are suitable for the IF stages, remember to precede ceramic filters with an LC stage. The IF stages will operate at up to 10.7MHz with no apparent loss of performance, but the layout requirements become far more stringent when working at these frequencies. We are always pleased to hear about customer's applications, and will be printing such circuits in subsequent issues - so if you have an interesting application, please write and advise us.

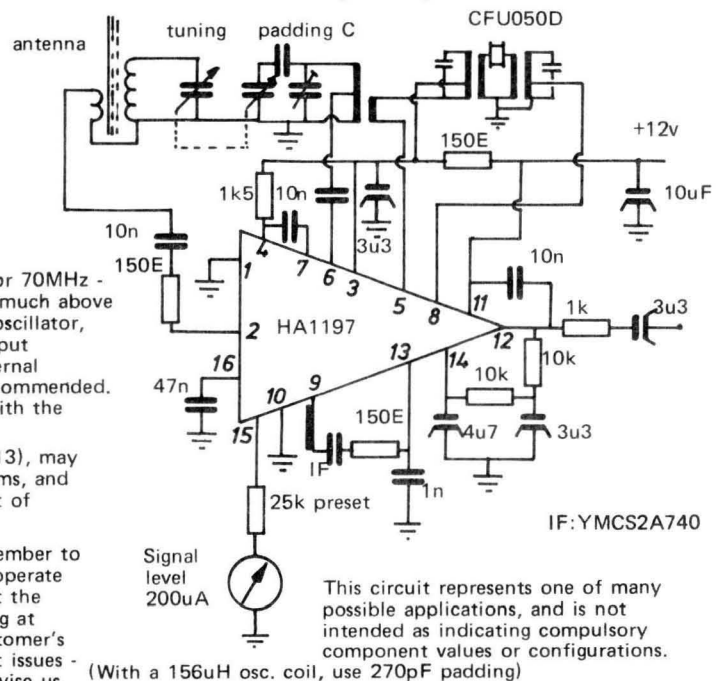

This circuit represents one of many possible applications, and is not intended as indicating compulsory component values or configurations. (With a 156uH osc. coil, use 270pF padding)



**Versatile audio**

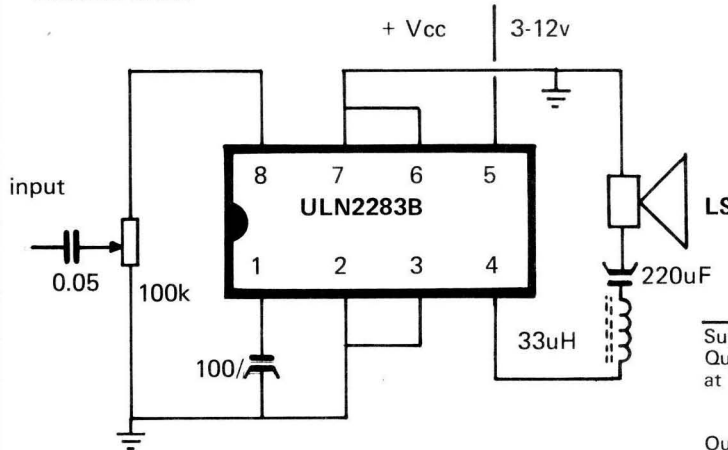

In the field of minimal external parts count audio the LM380 has been foremost for the past three years (did you notice we were the first to offer it for general sale ?) However, the LM380N does not generally operate below 8 or 9v Vcc.

So the new ULN2283B is an ideal alternative in many applications - since it operates from 3 to 12v at a minimal quiescent current.

	min	typ	max	
Supply voltage	3.0	6	12.5	volts
Quiescent current at Vcc 6v	8		12	mA
12v	14		20	mA
9v	10		14	mA
Output:12v/16ohms		875		mW

Voltage gain typ 43dB

The bias decoupling point at pin 1 requires a capacitor with a minimum voltage rating of 3 - and in many applications where power output is kept low, this capacitor may be reduced to as little as 10uF - but since the output stage is class AB, current peaks occur on volume peaks, and must not be allowed to re-enter the voltage amplification stages via the power supply line. The output coupling capacitor may similarly be reduced in size where full bass response is not considered essential - as in many battery applications, the speakers used would not respond in any case.

Notes: This IC is basically the same audio amplifier as used in the TDA1083 radio IC system. In cases where a low cost stereo portable radio is desired, the ULN2283B makes an ideally compatible 2nd channel amplifier. The voltage range makes this device ideal in battery operated equipment of all types - but in a radio environment, the same output lead RF decoupling precautions should be taken as suggested for the AF output of the TDA1083.

**Varicap tuning of AM: The latest installment**

Ever since Motorola announced the first low cost AM tuning diodes, the MVAM1 and MVAM2, interest has been running high with set manufacturers - but this has not yet been converted into a vast number of models on the market featuring this uniquely flexible and "programmable" approach to tuning. The mass-production problems surrounding the MVAM series centre largely on production spreads - which make reliable tracking and scale alignment a problem. The fact that until this new diode from TOKO, tuning voltages in excess of 12v were always considered necessary to be able to tune the MW and LW with a sufficient margin for the requirements of the market. So, now we have TOKO's KV1210 - the first to do the trick with only 9v ! This means operation in car radio is possible: and particularly important is the fact that most synthesiser systems for AM currently under development by GI, Hitachi and others, have a phase detector output that directly drives into this system - without an extra interface. As an additional benefit, the technique employed in the KV1210 has raised the Q of the device, and produced closer production tolerances in practise. The diode is presented as an integral triplet, with 1.5% matching - which has been met in the samples seen so far, with better than 1% being typical.

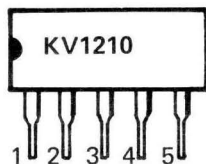

systems for AM currently under development by GI, Hitachi and others, have a phase detector output that directly drives into this system - without an extra interface. As an additional benefit, the technique employed in the KV1210 has raised the Q of the device, and produced closer production tolerances in practise. The diode is presented as an integral triplet, with 1.5% matching - which has been met in the samples seen so far, with better than 1% being typical.

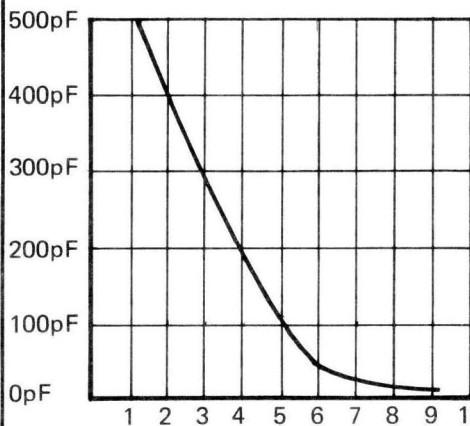

- Pin assignment:
- 1 Anode 1
  - 2 Common cathode
  - 3 Anode 2
  - 4 Common cathode
  - 5 Anode 3

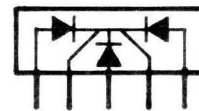

Parameter	min	typ	max	unit	
Reverse voltage			20	V	
Reverse current			100	nA	
Inter-terminal capacitance	Vbias 1v	400	500	560	pF
	Vbias 9v		35	pF	
Capacity ratio	C1v/C9v	15:1		(at 1MHz)	
Stray inter-terminal capacity		0.2		pF	
Q at Vbias 1v and 1MHz	200				

The temperature coefficient is typically 1000 ppm/°C at 1v bias

The 'spare' tuning ratio of the KV1210 permits tuning over the range 2-9v, thus assisting Q and overload characteristics at low frequencies. Theoretically, the necessary ratio to tune 525-1605kHz is approx 11 - but stray layout and trimmer capacitance increases this 'minimum' to a widely accepted datum of 15:1. To track an oscillator coil of 110uH nominal inductance, the oscillator section should be fed in series with 370-430pF - though the final value will depend on strays etc.

As an alternative to trimmer capacitors, and in order to keep all residual capacity as low as possible, the same arrangement as proposed in the TDA1062 BAnd 2 FM tunerhead is suggested.

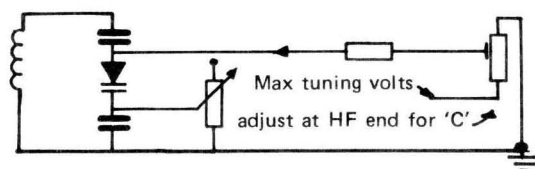

Typical circuit application

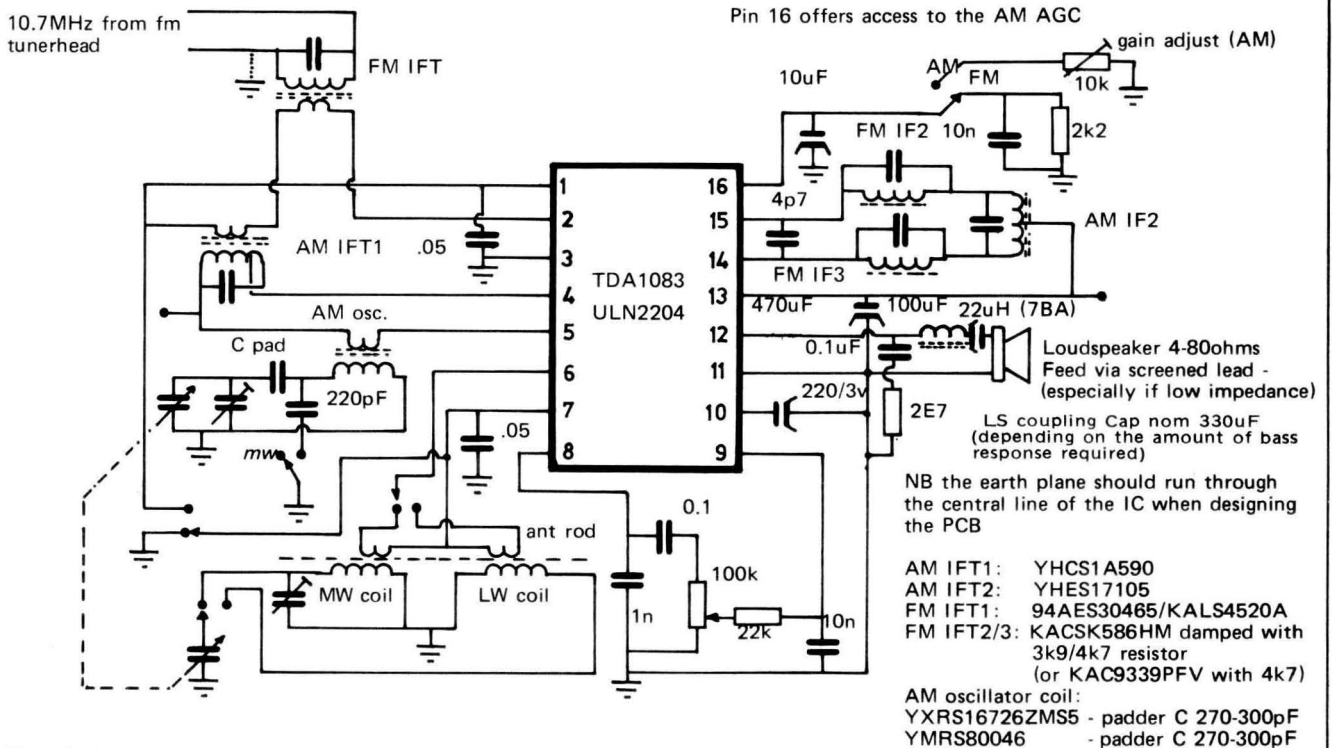

Description:

Electrical specification

Antenna for MW/LW: Ambit ET476/F14 18cms

Characteristics	Test Conditions	Typical Spec	Comments
<b>FM mode</b>			
f in:10.7MHz 75kHz dev. 400Hz modulation			
Input limiting threshold	10mV rms input	40uV	2-3uV when combined with simple two transistor front end circuit
Output THD	10mV rms input/30% AM	1.0%	
AM rejection	10mV rms input/30% AM	40dB	
<b>AM mode</b>			
fin:1MHz, IF:455kHz, 30%/400Hz modulation			
Sensitivity	for max. volume	9.0uV	The high sensitivity permits use of a TOKO IF filter whilst maintaining good overall gain
Overload distortion	80% AM	10mV	
Useable sensitivity		20uV	
<b>Audio amplifier</b>			
at 400Hz			
Gain		43dB	Quiescent I 10mA am/ 12mA fm 13mA am/ 16mA fm
Output power	Vcc 9.0v, 10% THD	800mW	
	Vcc 6.0v, 10%	250mW	

This is undoubtedly an IC with a big future in 1978 - the first really useable combined RF/IF/AF device that keeps all external components to a minimum, and maintains excellent performance in a superhet configuration. However, the design is a tried and tested one, since an American manufacturer has made over a million radios in the past couple of years, when the design was exclusively their own. We now offer this IC, together with a suitable selection of the World's finest coils and filters.

The device works down to an exceptionally low Vcc - typically only 2 volts - and it draws a very minimal current (under quiescent conditions). Overall current drain is obviously largely a function of volume level. We are interested to learn of any uses for the TDA1083/ULN2204 in the fields of hand-held communications equipment and radio control, and hope to be publishing further details of our own developments in future issues.

The stability of the circuit depends on layout - and in the case of the TDA1083, layout is not as critical as has been the case with all previous attempts at an "all-in-one" radio IC. The earth plane should run through the centre of the IC layout, and the speaker leads must be fed from a screened cable - but the intelligent layout of pin functions leads to a naturally satisfactory layout that is indicated by the circuit diagram itself. A choke of 22uH should be placed in series with the AF output on pin 12, since the negative current peaks from the AF amplifier can create a small spurious oscillation between 18 and 22MHz, that must be suppressed to prevent harmonic interference on FM. This applies specifically where loudspeakers of 16 ohms and below are used.

Simple low current two stage Band II tunerhead

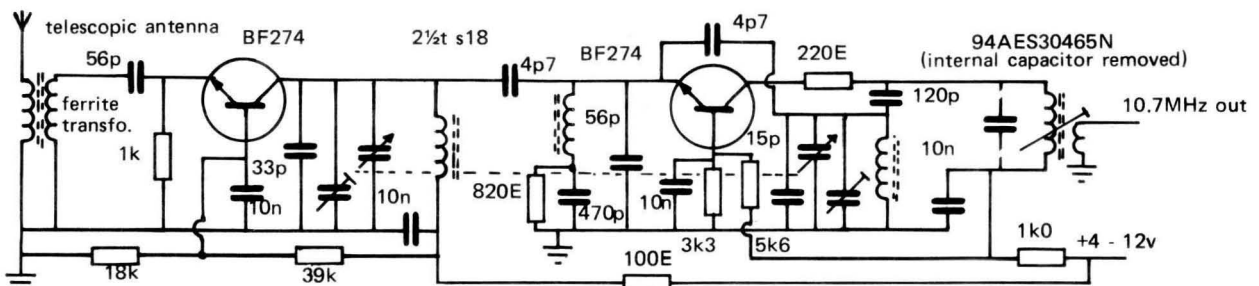

Tuning capacitor: 3.5 to 20pF per section ( or varicap)

In general applications, the BF595/BF395 is better suited than BF274, which occasionally show instability, due to their much higher ft characteristics.

See pages 53 to 57 for further information on the TDA 1083

The first complete VHF tunerhead semiconductor package to be successfully integrated into one IC package

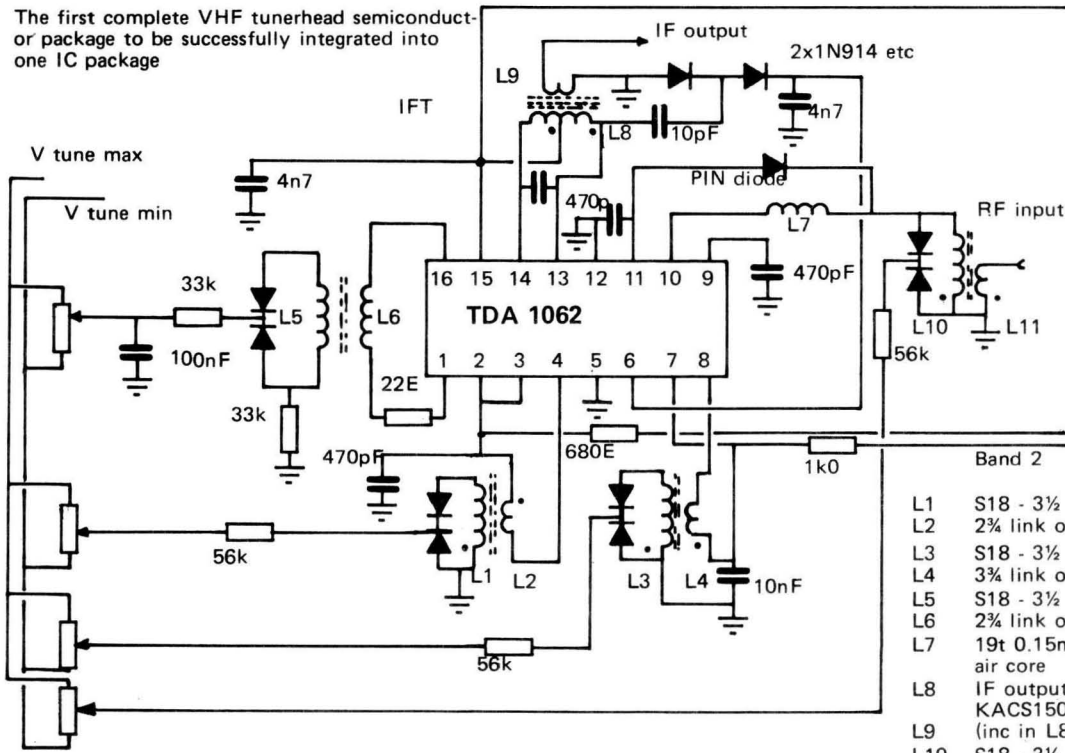

- L1 S18 - 3½ turn
- L2 2¼ link on L1
- L3 S18 - 3½ turn
- L4 3¼ link on L2
- L5 S18 - 3½ turn
- L6 2¼ link on L5
- L7 19t 0.15mm 3.5mm diameter air core
- L8 IF output coil [10.7MHz] KACS1506A (300 ohms) (inc in L8)
- L9
- L10 S18 - 3½ turn
- L11 1 turn link on L10

all presets  
100k lin

All TOKO S18 VHF molded coils to be used with VHF ferrite core  
L1 spaced 1.3cm[centres]from L3

**General**

The TDA1062 represents a real breakthrough in tunerhead design. VHF 'front ends' have traditionally been the black art of FM receiver design - and whilst the TDA1062 is a very much more predictable and workable approach than most discrete designs - it cannot completely override the considerations of good layout technique, shielding and short signal paths. The RF and mixer circuits will operate to frequencies in excess of 200MHz - the upper limit is primarily limited by the stability of the external layout - and the excellent characteristics of the internal double balanced mixer, coupled with the built in AGC facility, give the TDA1062 an exceptional large signal handling capability. Of great interest is the novel tuning system with varicaps, where the absence of trimmer capacitors permits the complete band of 88 to 108MHz to be tuned with just 2 - 7.5v bias. This compression of the tuning voltage range offers many advantages - immediately it will be seen that operation from a fluctuating 12v supply is quite feasible - but it also means that the stability and purity of the tuning voltage rail is emphasized, where a small error would create approx 3 times the hum/noise that would otherwise appear in a more conventional 20v bias system. Where 20v of tuning bias is available, however, the upper frequency range of the unit is greatly extended allowing reception into the aircraft band.

Characteristics:		Min	Typ	Max	Comments
at 25°C ambient, 10v supply, 95MHz					
Supply current	mA		30		
Supply voltage range	V	9		15	
Operating temp range	t°C	-25		+85	to +125 in storage
Tuning range from 2 - 7.5v bias	MHz	88		108	
Power amplification	dB		30		50 ohm source and load
Noise figure	dB		5.5		
IF bandwidth	MHz		0.5		
RF Bandwidth	MHz		1.7		
Image rejection	dB		80		Exceptional
IF rejection	dB		100		
Half IF rejection	dB		90		
Ultimate quieting	dB		70		
Oscillator pulling for 0dBm input	kHz		10		
Antenna input at AGC threshold	dBm		-30		With external PIN diode AGC
Oscillator radiation at antenna input	dBm		-60		7mV at the antenna
Tracking 88-108MHz	dB		1.5		Circuit uses most linear region of BB104

Typical layout viewed from top, as seen in the AMBIT 91062 tunerhead board. By changing the coil set, this board may be used to cover from 30 - 200MHz. See TDA1062 additional data for more design information covering all aspects of the unit's performance.

The additional track on the input coil is for input windings where 300/75 ohm windings are required.

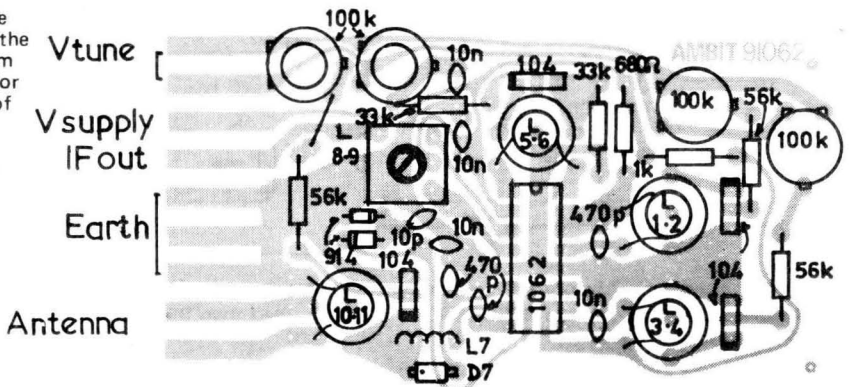

The MC1310P, CA1310E, SN76115N, HA1156W, KB4400, XR1310, SL1310 etc etc. Basic PLL mpX decoder

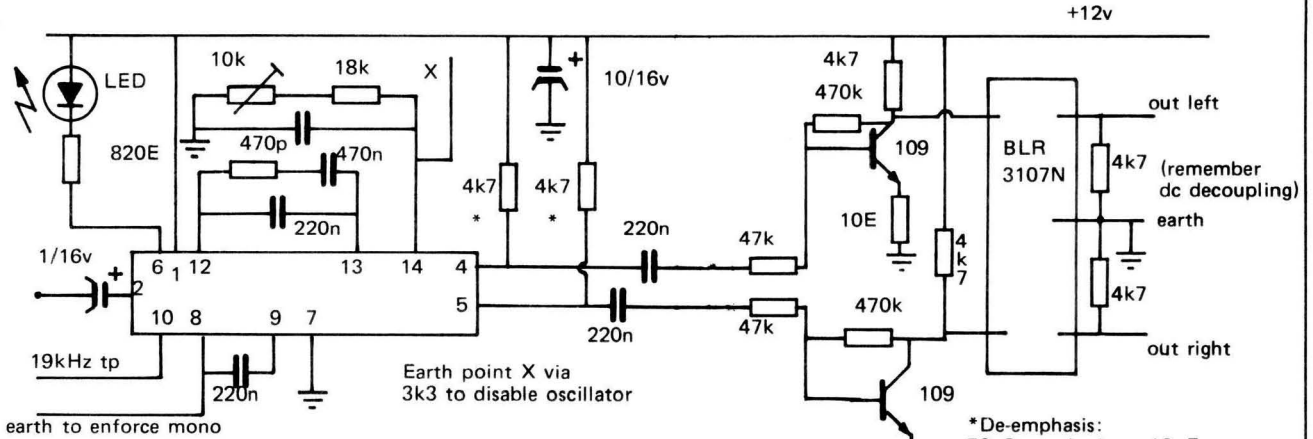

Much has been said and written about the MC1310 and its ilk, and so we will not go into great detail here - more data available on purchase of the IC or decoder module/kit

Input impedance	50k ohms	Supply voltage	8-16v DC
Channel separation	40dB at 1kHz	Supply current	13mA (no lamp)
Stereo THD	.3% max at 1kHz	Max input	1.3v rms
Output V	560mV in		
Pilot level to switch	16mV		
S/N ratio	76dB		

\*De-emphasis:  
50uS standard use 10nF  
75uS use in parallel with 4k7 on both channels

The one and only RCA CA3090AQ - the 'other' original PLL MPX decoder with never quite the same popularity as the 1310

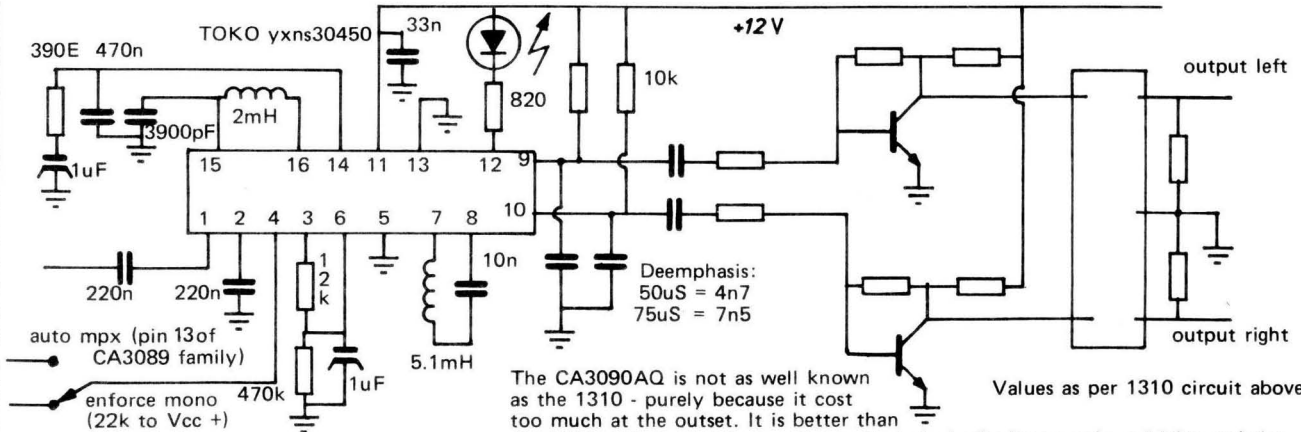

The CA3090AQ is not as well known as the 1310 - purely because it cost too much at the outset. It is better than the 1310 series in most respects, particularly in the improved sensitivity and the auto stereo switch feature

Input impedance	50k
Channel sep.	40dB at 1kHz
Stereo THD	.2%
Output gain	6dB (before amp)
Pilot to switch	4mV

Max input	400mV composite	1.2v	Supply voltage	9-16v
Voltage to enable stereo at pin 4			Supply current	22mA (ex. lamp)
S/N ratio	78dB			

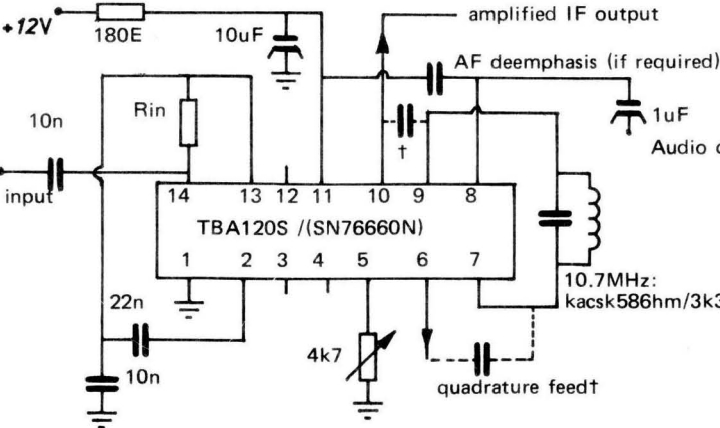

The capacitors marked † are not required at 6 and 10.7MHz in the TBA120S, as these are furnished internally.

Supply voltage range	6-18v dc
Supply current	15-20mA
IF voltage gain at 6MHz	68dB
IF voltage at limiting (6&10)	170 - 250mV
AF output voltage	700-1000mV
THD	3-4% (at the high AF level stated)
Input limiting voltage	30-60uV
Input impedance	40k/5pF
AM rejection at 10mV input	68dB

The TBA120/ 120S and SN76660N

This family represents one of the original series of FM IF amplifier and detectors - developed primarily with TV sound IFs in mind. The device includes an internal zener stabilized supply, and an audio output attenuator, operated from pin 5. This is a strictly DC control, and may thus be operated remotely if desired. As an IF/detector it has largely been superseded by the CA3089E, but in specialized applications, it still offers certain advantages, and excellent value.

The device may be used simply as an IF amplifier, where the internal DC coupling enables operation down to the bands used in ultrasonic and infra red remote controllers. The quadrature is simply a parallel resonant circuit, with Q arranged for the desired compromise between output and THD

The SN76660N is identical, except that the quadrature feed capacitors (†) are not internal. This allows access to the excellent balanced mixer within the IC, which may be used in a variety of applications from SSB to general IF mixer functions - and is quite one of the cheapest ways of finding such a facility.

Devices TBA120B are simply the SN76660N type supplied in 14 QIL. Devices denoted TBA120A and TBA120AS are also supplied in QIL packages. The internal 12v zener is from pin 12 to ground - those of you wishing to modify the application are advised to study the internal data - available on purchase of the IC

This is a high gain wideband device, and so the layout must be carefully chosen to observe good RF techniques - even when using the device at apparent low frequencies.



The Ca3123E/uA720/LM1820

Although primarily intended for applications as AM systems, this family is well suited to a variety of RF/IF gain applications, that include multifunction (AM/NBFM/SSB) operation in the region 0.1 to 30MHz (RF section) and up to 2MHz in the IF stages.

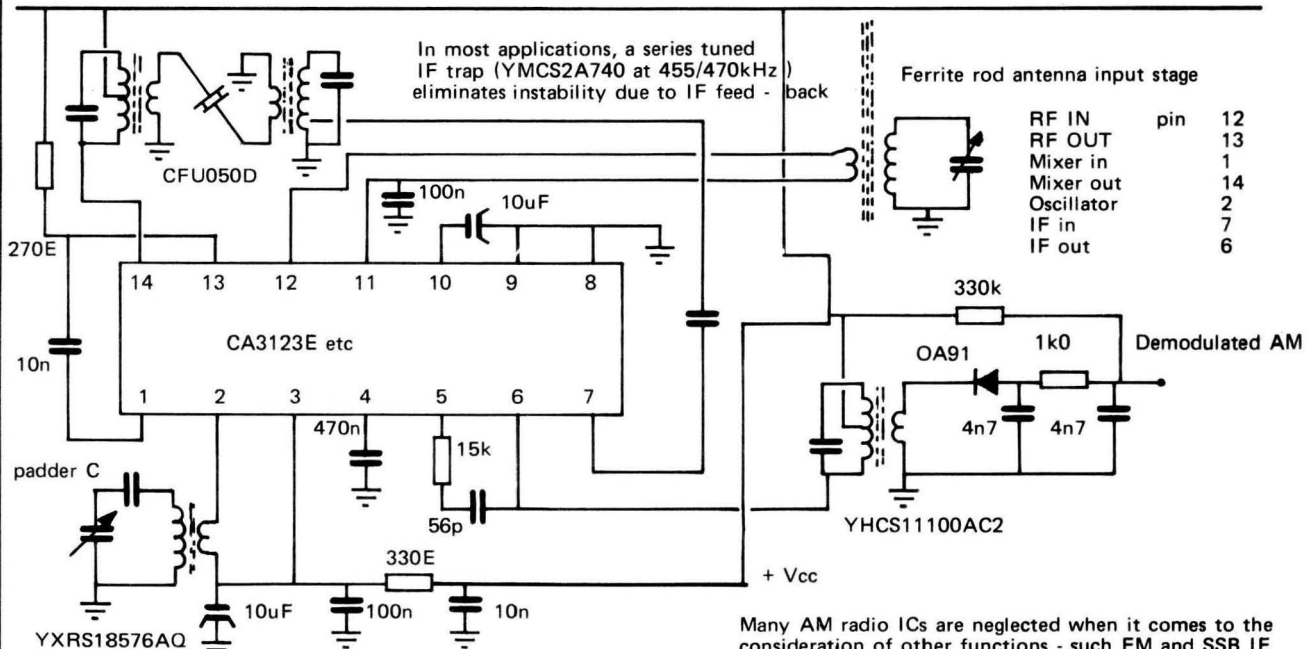

YXRS18576AQ (100uH for MW)

Specifications

Operating voltage range	V	7 to 16
Supply current	mA	14 to 22
RF section input R/C (pin 12)		1k/80pF
Mixer input R/C (pin 1)		1k4/8pF
IF input R/C (pin 7)		1k0/70pF
Transconductance of RF	mho	120m
of mixer	mho	2.5m
of IF	mho	90m

$$\text{Gain of a stage} = \frac{V_{out}}{V_{in}} = K_1 g_m R_L N K_2$$

where  $g_m$  is the transconductance, and  $K_1$  &  $K_2$  are the 6dB matching losses for output/input impedances.  $N = Z_{secondary} / Z_{primary}$

Many AM radio ICs are neglected when it comes to the consideration of other functions - such FM and SSB IF stages - when the basic AM radio IC is an excellent and well defined solution. Instead of using the peak detector diode - simply use the amplified IF at this point to drive into the relevant detector system.

This IC has a well designed bandwidth, with the RF and IF responses tailored their specific functions - not provided with a pointlessly wide frequency response that would only lead to uncontrollable instability in the long run. Under optimum matching conditions, 125dB of gain is possible, though in practical applications, this gain is reduced to avoid feedback instability problems. Full device data includes all the necessary design parameters for applications calculated from basic principles.

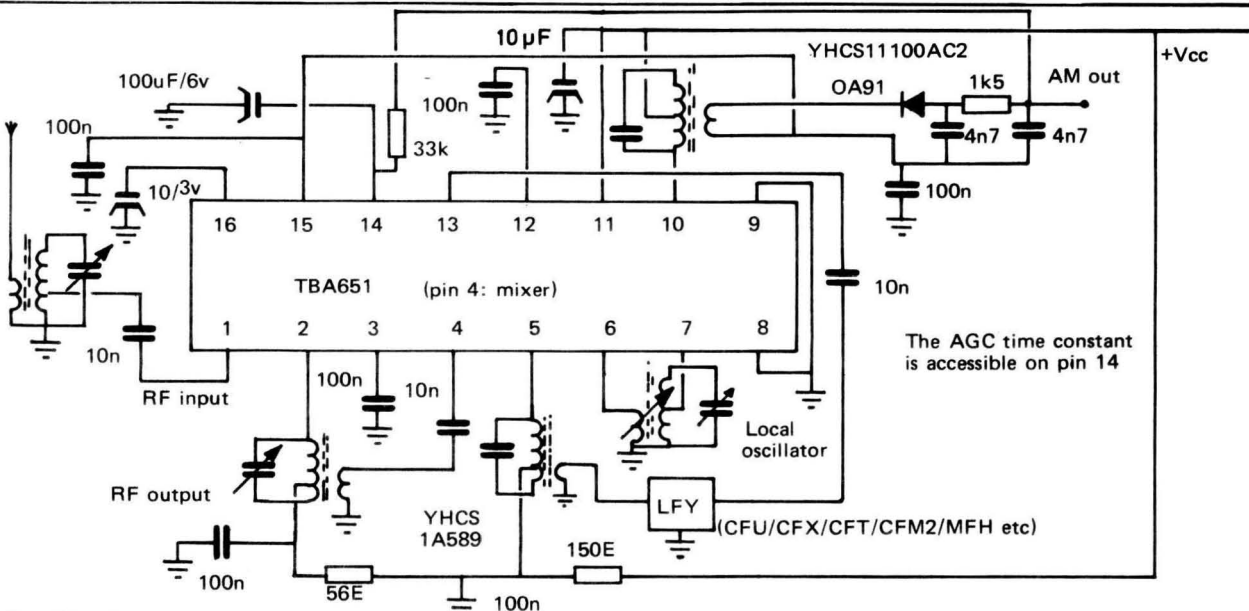

Specifications

Operating voltage range	V	6 to 18V
Supply current (12v supply)	mA	11.5
Input conductance of RF	$m\Omega^{-1}$	0.7
Mixer		0.4
IF		0.25
AF voltage (80% mod)	mV	500
S/N ratio for 10uV input	dB	26
Input range for 10dB AF change	dB	80

The IF output of both the TBA651, and the CA3123E is an open collector of the mixer stage. All types of filters may be used, but always drive the IF into an LC tuned circuit first, with secondary impedance to suit the chosen type of filter.

Like the CA3123E, the TBA651 is more than just an AM radio IC - but unlike the CA3123E, the TBA651 is wideband throughout, and thus requires very careful layout to achieve stable performance. The RF output stage tuned circuit at pin 2 should be kept to a low Q of about 40 - which may require an additional damping resistor across the tuned circuit.

The internal oscillator of the TBA651 is not suitable for HF work, so an external oscillator should be injected into pin 7. Pin 7 should be taken to ground via a 1k resistor, and pin 8 via 330 ohms, decoupled with 10nF. The internal oscillator is quite satisfactory up to frequencies of 4-5MHz, and requires a conventional oscillator coil - with either tapped primary, and secondary - or three separate winding format.

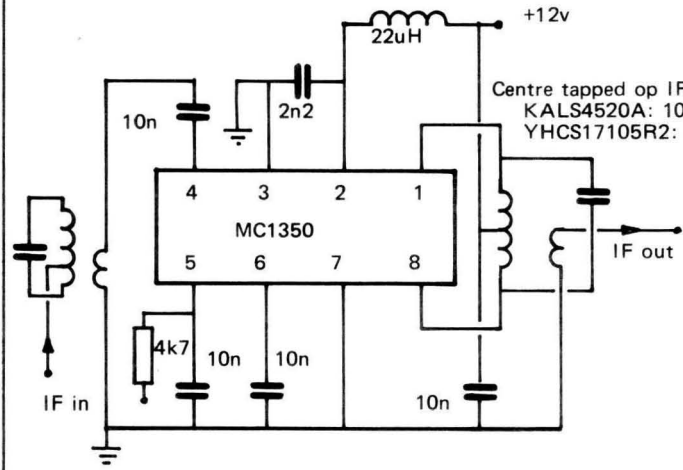

Gain control :  
Pin 5 via 4k7, for max gain 5v required  
-60dB agc at 7v bias

General:

The MC1350 is a gain controllable linear IF amplifier operating from LF to 60MHz. AGC is effected by increasing the voltage on pin 5 at an AGC current of between 100 and 200 uA. In common with all HF ICs, good layout is essential, with low impedance earthing at all decoupling points.

Specifications:	unit	min	typ	max
Operating voltage range	v	6	12	18
AGC voltage		as supply voltage		
Differential input	v	5		
AGC range	dB	60	68	
Power gain (pin 5 0v)	dB		48	
at 58MHz	dB		58	
at 10.7MHz	dB		62	
at 455kHz	dB			17
Total supply current	mA	14		
Single ended input C	pF	7.2		
S-E input admittance	mmho			
g <sub>11</sub> at 455kHz			.31	
10.7MHz			.36	
58MHz			.5	
b <sub>11</sub> 455kHz			.022	
10.7MHz			.50	
58MHz			2.75	

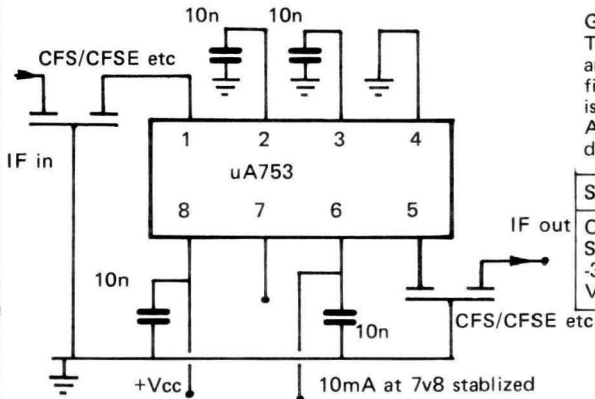

General:

The uA753 is a simple to use limiting IF gain block, specifically for FM IF amplifiers. The 330 ohms input/output terminations necessary for ceramic filter matching are provided within the IC itself. A low level output IF signal is provided at pin 7, before the final differential amplifier stage. A 7v8 thermally regulated and stabilized 10mA output is provided via the device internal regulator.

Specifications:	unit	min	typ	max
Operating voltage range	v	10		16
Supply current	mA	11	16	19
-3dB limiting threshold	uV		900	
Voltage gain at 10.7MHz	dB	40	50	56

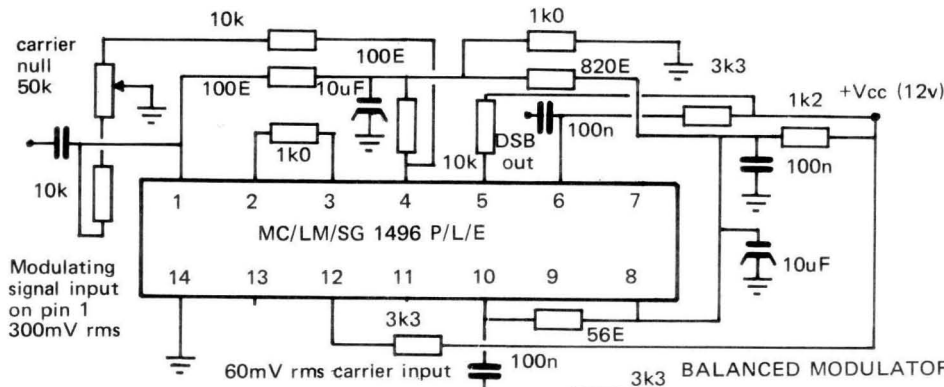

General:

The LM1496 series is a particularly effective balanced mixer, that may be used in a variety of applications to produce:  
AM modulators  
DSB modulators  
Synchronous demodulators  
SSB demodulators (product detectors)  
FM/Phase detection

The most popular use for the IC is probably in the product detector mode, where an SSB sensitivity of only 3uV (at 9MHz) is possible. The basic feature of this (and other balanced systems, being an excellent dynamic range. In this instance 90dB.

As a balanced modulator at 455kHz, the 1496 provides 65dB of carrier suppression, and when fed into a suitable SSB filter (the MFL has been used successfully), the resulting 455kHz SSB signal may be successfully mixed to the desired PA frequency.

Persons wishing to employ this device in custom designs are recommended to read the full data (50p) which gives many details of parameters and design considerations.

The circuits given here are quite workable in their own right, and are recommended as being the most effective and high performance means of achieving DSB generation, and SSB demodulation. Input/output connections may be made via IF transformers of a suitable frequency.

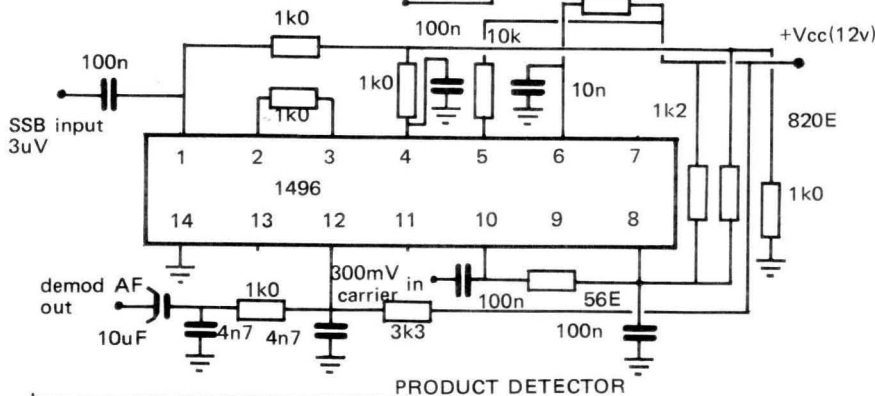

Specifications		
Supply voltage	V	10-30v
Supply current	mA	10
Carrier suppression	dB	65 at 500kHz
	dB	50 at 10MHz

Coupling capacitor values should be adjusted according to frequency range

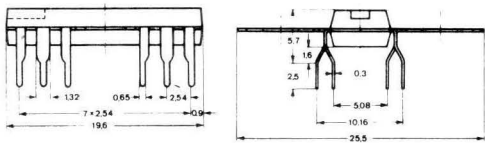

The TBA810AS and TCA940 are interchangeable audio power ICs - the only differences being the increased supply voltage capability of the TCA940, coupled with the increased output power of the TCA940

These ICs represent the "standards" of both amateur and industry, and are now manufactured by more sources than almost any other consumer linear IC. They are both short circuit protected outputs, operating from wide supply voltages, and consuming a minimal quiescent current under no-signal conditions.

Features

- ★ Thermal shut down
- ★ TBA810 : 7W rms at 10% THD
- ★ High sensitivity
- ★ High output current into 4 Ω
- ★ TCA940 : 10W rms at 10% THD
- ★ High input resistance

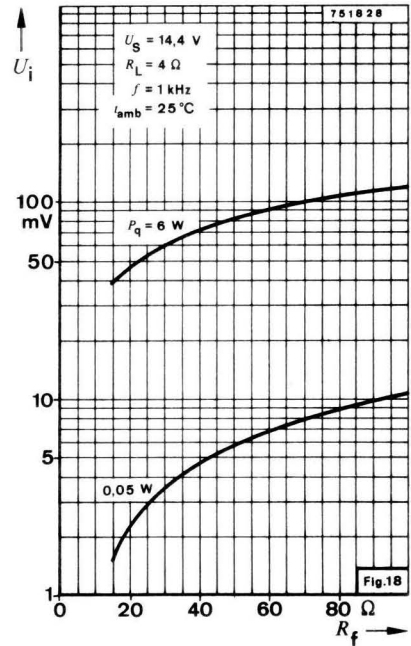
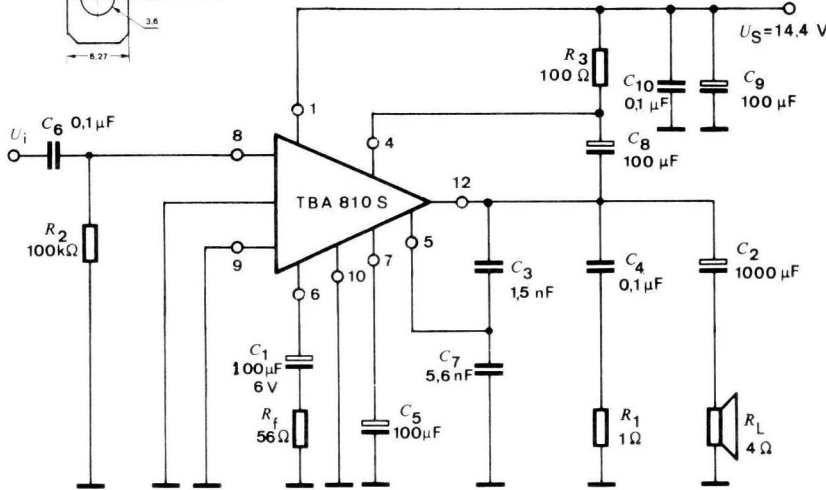
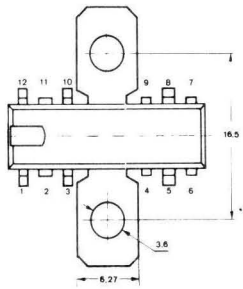

Specifications		Min	Typ	Max	
Parameter	TBA810AS - TCA940				
Supply voltage		4 6		20 24	V V
Quiescent output voltage with 14.4v supply		6.4	7.2	8	V
	18.0v	8.2	9.0	9.8	V
Quiescent drain current with 14.4v supply			12.0	20.0	mA
	24.0v		20.0	42.0	mA
Total supply current 6W / 4Ω / 14.4v supply			600		mA
	9W / 4Ω / 18v		770		mA
Thermal shut down temperature			120°C 110°C		
Supply voltage rejection ratio			48 45		dB dB
Output power : 4Ω/ 1kHz/ 10% thd	16.0v		7		W
80mV input	14.4v		6		W
	9.0v		2.5		W
	6.0v		1		W
	20.0v		10		W
90mV input	18.0v		9		W
	16.0v		7		W
Input resistance			5		MΩ
Input noise voltage			2 3		μV μV
Efficiency : 5W/ 14.4v/ 4Ω/ 1kHz			70		%
	9W/ 18.0v/ 4Ω/ 1kHz		65		%

When using these ICs, remember that they are layout critical, in much the same way as any HF device. The very heavy current drain means that low impedance, well designed earth paths are essential; pin 9 is the input earth, pin 10 the output earth, so ensure that pin 9 doesn't get to the circuit earth point through that of pin 10. In the same way, ensure that the output Zobell network earth is associated with the output earth at pin 10. The absence of this Zobell network will invariably lead to HF instability under heavy current drain conditions, and possibly ultrasonic instability causing the device to heat up rapidly, with no apparent audible effects.

Both the TBA810AS and the TCA940 are going to draw heavy current on signal peaks, and this means that the power supply voltage is likely to fluctuate considerably, unless care is taken to provide heavy current regulation. In battery equipment this is generally not possible, so make certain that any circuits associated with this are well decoupled in their own right's - or the effect is likely to be low frequency oscillation, peak distortion etc. Always remember to earth the tabs, and prevent HF signals from reaching the input - where they are likely to be unduly amplified, and create instability and inaudible overload problems.

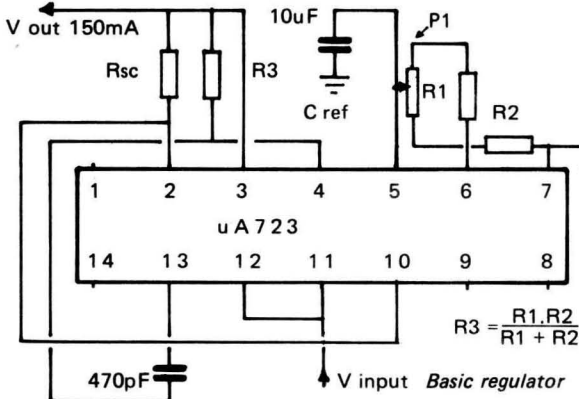

The 723 is the classic IC voltage regulator IC. With few external parts, the device can be made into a complete PSU of extremely high performance. Once again, remember that HF considerations apply, so good supply decoupling is necessary

**Specifications** uA723CN

Continuous input voltage	40	v
Power dissipation max.	660	mW
Operational temp range	0 - +70°	C
Line regulation Vin 12-15v	.01	%
12-40v	0.1	%
Load regulation load current 1mA-50mA	.03	%
Ripple rejection 50Hz to 10kHz	86	dB
Av. temp coeff. of output	.003	%/°C
Short circuit current limit (Rsc 10Ω)	65	mA
Output noise voltage C ref 10uF	2.5	uV
Standby current drain	1.3	mA
Input voltage range	9.5 - 40	v
Output voltage range	2.0 - 37	v
Input/output voltage differential	3.0 - 38	v

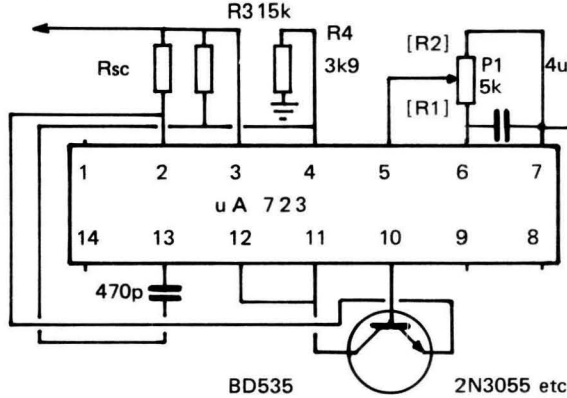

**Pin functions (DIL package)**

- 1: nc 2: current limit 3: current sense 4: Inv. input
- 5: non-inv. input 6: Vref 7: V- 8: nc 9: V zener
- 10: V out 11: Vc 12: V+ 13: Frequency comp
- 14: nc

The 723 output voltage is determined by the following in the basic regulator circuit:  $V_{ref} \frac{R1 + R2}{R2} = V_o$

and the current limit  $I_{limit} = \text{Sense voltage}/Rsc$

In the case of the pass transistor output version:

$$V_o = V_{ref} \frac{R2}{R4} \frac{R3 + R4}{R1 + R2}$$

Sense voltage = 0.66 v at 20° 0.57v at 75° (C)

(Full manufacturer's data (National) 5 pages)

Values chosen for 7 -35v output range

High current regulator with external NPN pass transistor

**78XX series three terminal voltage regulators**

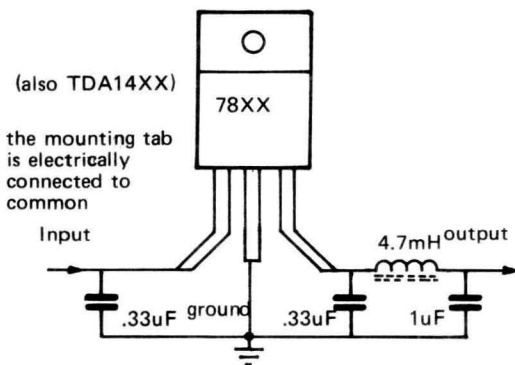

Three terminal voltage regulators are now well established as the leading means of achieving power regulation at fixed voltages. They are thermally protected and compensated - and apart from a tendency to produce RF noise, they are ideal for any application within their specification.

**Specifications**

PARAMETER	78XXC	78MXXC	78LXXC
Max load current	A 1	0.5	0.1
P dissipation free air	W 2*	1.0	0.7†
P .. inf heat sink	W 15	5	1.7
Max load regulation	% 2	2	2
Max line regulation	% 2	2	2
Max quiescent I	mA 8	8	6
Typical ripple rejection	dB 70	65	74
Typ. dropout voltage	V 1.5-2	1.5-2	1.5-2
Thermal resistance °C/W	4*	5*	40†
Max input voltage **	V 35	35	35

\* TO220 † TO92 \*\* 40v for 20 & 24v devices

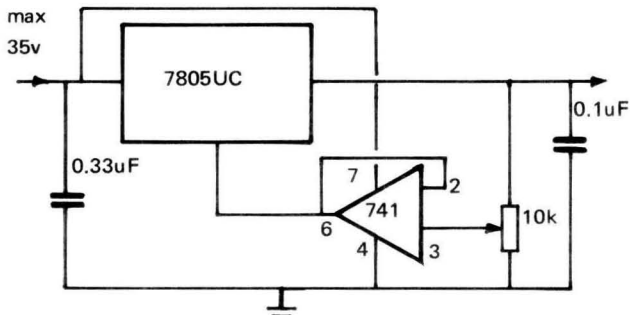

7 to 30v adjustable regulator  
Output current depends on heatsink of 7805

The three basic types offered here are positive voltage regulators where the main selection factor is the power dissipation sought. This is determined by subtracting the output voltage from the input voltage, and multiplying by the max current required.

eg 18volts in, 12v out at 200mA  
 $6 \times 0.2 = 1.2W$

which is either covered by the 7812UC in free air conditions or the 78M12UC with a small heatsink. The heatsink is derived from the heatsink transfer characteristics, given in the form of the numbers of degrees C by which the heatsink ambient temperature rises per watt dissipated.

The maximum junction temperature is not the case temperature ! Where the max. junction temperature is given as 125°C - this indicates the onset of the thermal shutdown, so always aim to achieve a case temperature of 100°C max to allow for rises in ambient temperature conditions.

Earthing, once again, deserves special attention. As a general rule it is best to earth the regulator circuit to the same point as the rectifier / transformer circuit. The 78XX series are just as prone to HF instability as any other linear gain system, and so please note the careful decoupling described above. The 'π' section LC filter shown is advised for PSUs in radio reception equipment, in DC and AF applications, simply use 1uF - though better ripple rejection may be achieved with 100 -470uF.

The rapid switching effects in silicon rectifier diodes may also lead to problems in PSU design, and when tracing noise in a PSU, do not overlook this possibility, and decouple each diode with 0.1uF ceramic discs .

Basic application

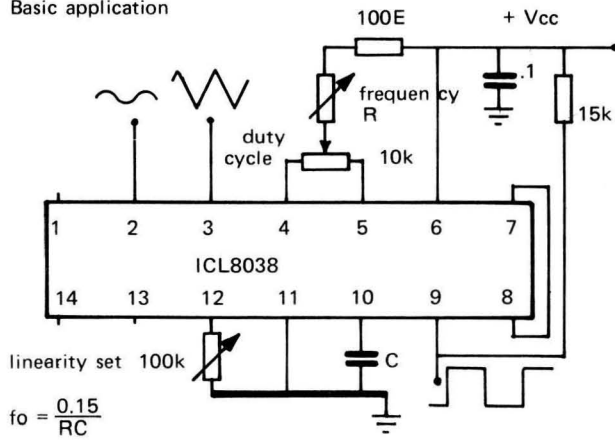

The 8038 is an exceptionally versatile waveform source for various applications in test equipment, musical sources, tone generation. Sine, square and triangle outputs are simultaneously available, with excellent amplitude stability.

Specifications

Characteristics	unit	min	typ	max
Supply voltage	V	10		30
Supply current	mA		12	20
Frequency range	Hz	.001		1M
FM linearity	%		0.2	
Square wave amplitude	xVcc		0.9	
Rise time	nS		100	
Fall time	nS		40	
Duty cycle adjustment	%	2		98
Triangle amplitude	xVcc		0.33	
Linearity	%		0.05	
Sine wave amplitude	xVcc	0.2	0.22	
THD in 1M	%		0.8	3

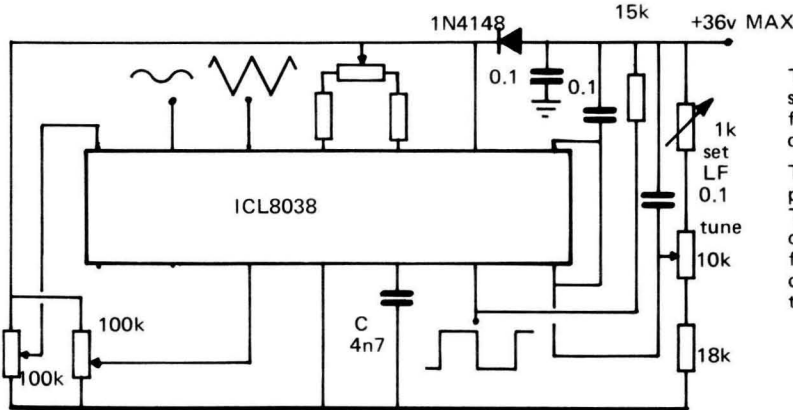

The circuit shown here represents a complete AF signal source. The outputs should be buffered in voltage followers, and provided with attenuators to suit the desired application

The 8038 may also be used as a linear FM source - or phase locked to a reference in synthesis applications. The sweep input (pin8) permits operation in a variety of effects modes - and consequently, the 8038 has frequently featured in circuits published over the past couple of years. (Ambit were the first to bring you the 8038 - now almost a 'standard' !)

sinewave linearity

20Hz to 20kHz audio oscillator

NE555

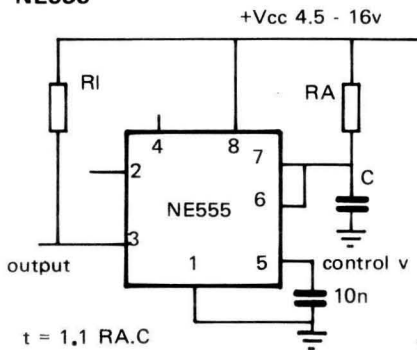

monostable - one-shot  
Time delay

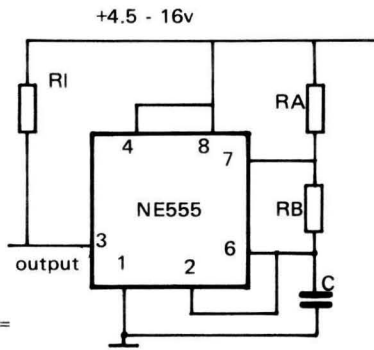
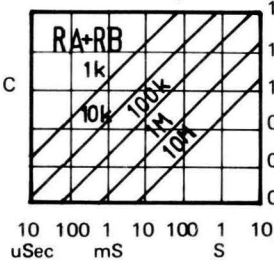

Frequency of operation  
multivibrator

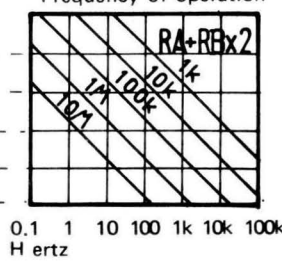

NE566

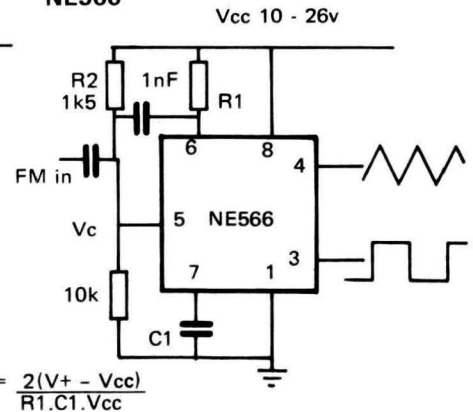

fo = 2(V+ - Vcc) / R1.C1.Vcc

The NE566V is a wide range triangle/square wave function generator which can also be modulated over a ten to one range by a suitable choice of components

The NE566 is widely used in-MF tone signalling and communications, and may be used in some 8038 applications where the sinewave output is superfluous.

The standard timer: microseconds to hours

Specifications	unit	min	typ	max
Supply voltage	v	4.5		16
Temperature drift	ppm/°C		150	
Supply voltage drift	%/V		0.01	
Threshold voltage	%Vcc		66	
Trigger voltage at Vcc 15v	V		5	
Trigger voltage at Vcc 5v	V		1.67	
Trigger current	uA		0.5	
Reset voltage	V	0.4	0.7	1.0
Current sink/source	mA		200	
Power dissipation	mW		600	

Parameters	min	typ	max
Supply voltage	V	10	10
Temp drift	ppm	200	
Supply current	mA	7	12.5
Max frequency	MHz	1	
Supply v drift	%/V	2	
Control terminal input impedance	ohm	1M	
output impedance	ohm	50	
Triangle output	V	2.4	
Square output	V	5.4	
Rise time	nS	20	
Fall time	nS	50	

pp Vcc 12  
pp Vcc 12

Basic configuration: (with Zobell network for high current loads)

The LM380

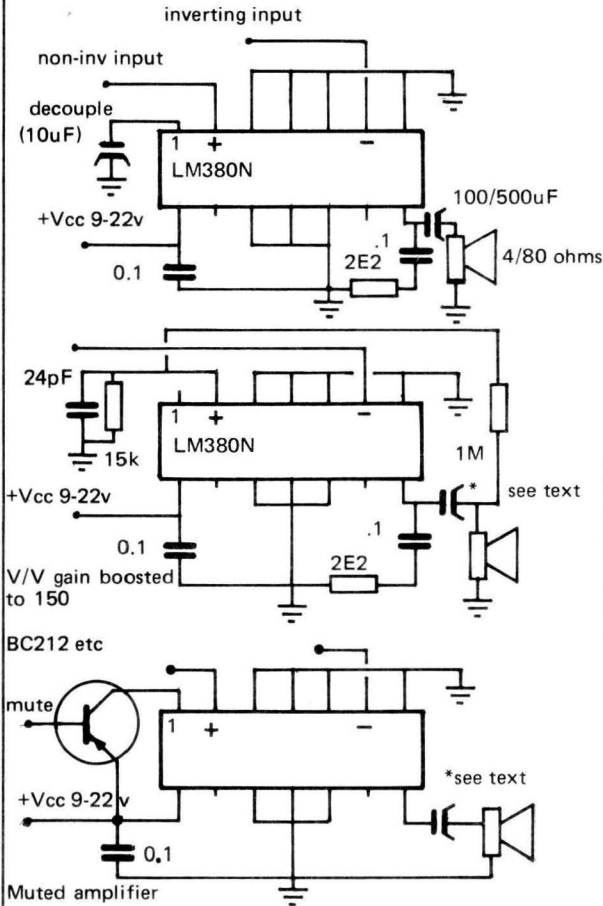

Of all the ICs introduced to the enthusiast/home constructor by Ambit, the LM380N is amongst the best known. It is one of the simplest and most effective means of delivering speaker volume power, providing up to 3W rms into 8Ω with a 20v supply. The basic configuration is shown here to include the zobell stability network at the output pin, which is particularly necessary when driving high current loads, to prevent HF instability. The value of the loudspeaker coupling capacitor (\*) depends on application - for in many test amplifier and communications applications it is not necessary to exceed 100uF since the bass frequencies lost thereby would only be wasted in excess current drain. Being basically class B, power drain is directly proportional to the level of volume selected. The two inputs correspond to the + and - input of an op-amp - and in many respects the action of the LM380 may be likened to the behaviour of an op-amp, except that gain here is internally fixed at 50 V/V. (Although this is shown as increased in the second application)

Pin 1 is a supply bypass point, and may be decoupled to provide additional hum rejection. It also permits the amplifier to be easily and effectively muted with the additional of a single external PNP transistor, by pulling pin 1 to the positive supply to mute.

Specifications

Parameter	unit	typ
Input resistance	k ohm	150
Bias current	nA	100
Gain	V/V	50
Output voltage swing	Vp/p	Vcc - 4
Quiescent supply current	mA	7
Quiescent output voltage		½Vcc
Bandwidth (2W into 8ohms)	kHz	65
Supply voltage	V	9 to 22
Short circuit current	A	1.3
THD	%	0.2

The device has both thermal, and current output limiting, making destruction difficult - though not impossible ! Reverse insertion into a socket with a low impedance power supply is hazardous. Adequate heatsinking is necessary to achieve max output before thermal shutdown occurs.

Power output into 4 ohms: 14v/2.5W, 12v/2W  
8 : 20v/3.5W, 12v/1.25W

[SL60745 alternative part number]

The LM381

The LM381 is an extremely high gain preamp for dual channel operation - the layout of pin functions is essentially symmetrical, allowing best channel isolation, and preventing feedback instability. Once again it may be likened to an op-amp, characterized for audio applications. It has very many HiFi applications in filter stages, preamps, tone controls etc., and also instrumentation applications, where the high gain is available over a wide bandwidth. An applications and design leaflet is available for 50p, with most formulae and worked examples applicable to various op-amp amplification stages.

Specifications at 14v Vcc

Parameter	unit	typ
Input resistance	ohm	100k (+ input) 200k (- input)
Open loop voltage gain (single ended)	V/V	320,000
Supply voltage range	v	9 - 40v
Supply current	mA	10
Output resistance (open loop)	ohm	150
Output current source	mA	8
Output current sink	mA	2
Output voltage swing	V	Vcc - 2
Small signal bandwidth	MHz	15
Power bandwidth 20v pp output	k Hz	75
Maximum input voltage for linear op	mV	300
Supply rejection ratio	dB	120
Channel separation	dB	60
THD with 75dB gain at 1kHz	%	0.1
Total equiv. input noise (Rs 600ohm)	uV rms	0.55
Noise figure	dB	1.0
	dB	1.3
	dB	1.6

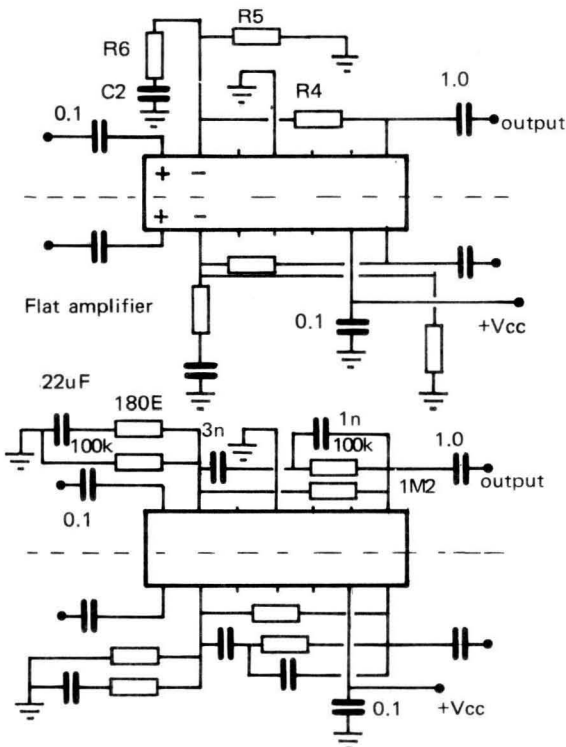

RIIA amplifier  
(Input should be loaded to suit cartridge impedance)

In view of the wide bandwidth of the LM381, a ferrite bead should be placed as near to the input pins as possible - and the power supply should be decoupled as close to pin 9 as possible via a 0.1uF. An additional capacitor (between pins 5/6 and 10/11) provides an HF rolloff facility - details of which are included in the LM381 application note.

Determining gain: in the 'Flat' (ie no frequency compensating feedback) configuration:

$$\frac{R4 + R6}{R6} \text{ and } C2 \text{ sets lower } -3\text{dB point where } C2 = \frac{1}{2\pi f_o R6}$$

$$C \text{ rolloff} = \frac{1}{2\pi f \cdot 2,600 \cdot 10^{A/20}}$$

where f is the HF -3dB point, A is the mid-band gain in dB

Pin functions

+Vcc 4 to 36v

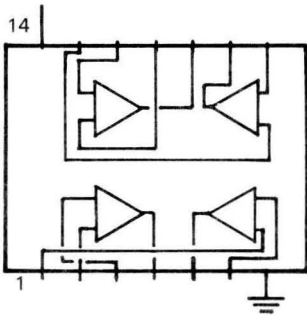

**The LM3900: general**

In the majority of op-amp configurations, the LM3900 offers a low cost alternative, together with less exacting supply voltage requirements. The universality of the LM3900 is almost unequalled in linear IC technology, and with a little thought, the LM3900 can be persuaded to perform a really vast number applications. Basically, it is an excellent audio processing device in simple amplification configurations, through to variable Q active filters. The presentation of four amplifiers in one package permits easy reduction in space requirements in quite complex circuits - and despite the apparent low cost, specialized audio op-amps costing far more have only marginal benefits.

**Specifications**

Parameters	Min	Typ	Max	Unit
Supply voltage	4	12	36	V
Supply current		6.2	10	mA
Open loop voltage gain at 100Hz	1.2	2.8		V/mV
Input R at inverting input		1		M ohm
Output resistance		8		k ohm
Input bias current		30	200	nA
Slew rate		0.5		V/uS
		20		V/uS
Output voltage swing		Vcc -1		V p-p
Output current capability (source)	6	10		mA
Output current capability (sink)	0.5	1.3		mA
PSU rejection ratio		70		dB

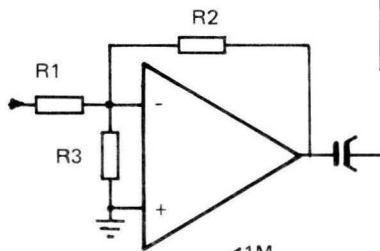

Application 1 V<sub>BE</sub> Biasing

$$V_{out} (DC) = 0.5 \left(1 + \frac{R2}{R3}\right) \quad \text{Amplification } (V) = \frac{R2}{R1}$$

This is the basic AF amplifier - select value to set V<sub>out</sub> (DC) between the supply voltage for best dynamic range. Frequency compensation in the feedback loop can be designed for RIAA etc equalizations.

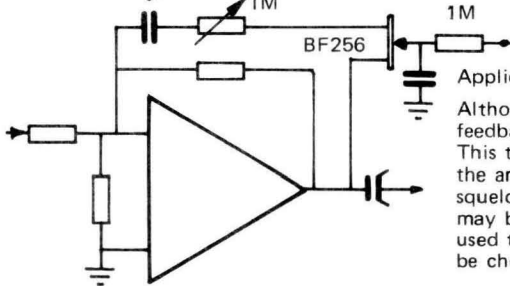

Application 2 Voltage controlled gain

Although the configuration is essentially similar to that of the basic AC gain stage, the feedback (AC) includes a voltage controlled resistor, in the shape of the BF256FET. This type of amplifier is useful in a variety of situations: talk over in mixers - where the amplified mic signal is rectified to produce the necessary control voltage, linear squelch in radio receiver applications, where the input time constant on the FET gate may be adjusted for the rate of change of attenuation desired; the 1M pot may be used to adjust the degree of gain reduction desired, and the capacitor in series may be chosen to suit the frequency characteristic desired.

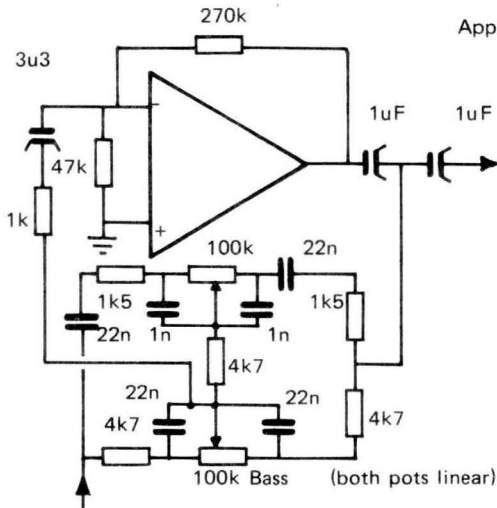

Application three active tone control

The values shown here (with a 12v supply) offer approx. ±17dB of tone control.

**A complete mixer with prefade/talk over/tone control/VU**

This complete circuit is scheduled to appear in one of our subsequent issues, and provides a complete stereo control preamp for disco applications, sound distribution, home movie sound mixing etc.

The block diagram omits many of the necessary components, and is only intended as a guide.

Every amplification function is performed inside an LM3900 section, and provides an overall THD better than 0.1% ! One of the great advantages of using the LM3900 is the pre-settability of the various gain stage amplifications, and the wide dynamic range available

due to the output swing capability of the basic LM3900 gain stage. The prefade monitor is switched between the various input amplifier outputs, and fed separately to a monitor PA of the desired level.

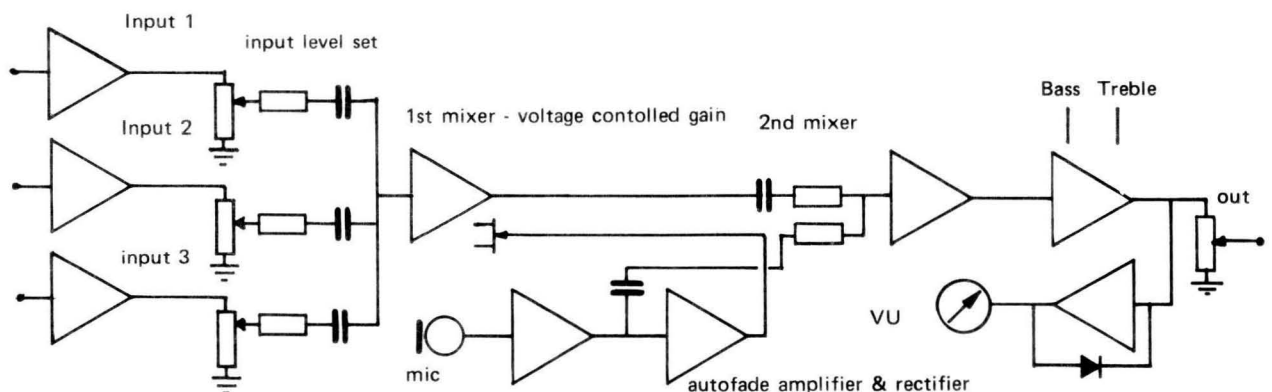

**Trimmer capacitors, foil and ceramic types. 7.5mm and 10mm diameter**

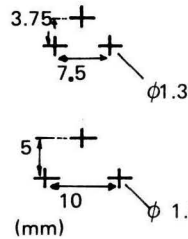
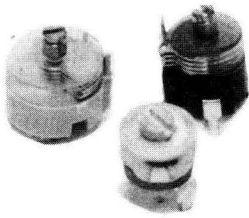

PCB drilling detail

TC1	Grey with clear top	1-5.5pF foil	7.5mm dia
TC2	Grey with yellow top	1.5-10pF foil	7.5mm dia
TC3	Grey/green with green top	2-22pF foil	7.5mm dia
TC4	Black with violet top	3-65pF foil	7.5mm dia
TC5	Grey with blue top	2-13pF foil	10mm dia
TC6	Grey with yellow top	5.5 - 60pF foil	10mm dia
TC7	Ceramic	5-30pF	7.5mm dia
TC8	Ceramic	7-35pF	7.5mm dia

**Ferrite Beads, transformer cores, rods**

Actual size shown



FX1115

Basic ferrite bead parasitic oscillation suppressor: use on audio leads to prevent RF pickup each bead used increases the inductive reactance of the lead, thus preventing stray HF interference on eg magnetic cartridge pickup input leads, without affecting AF performance and characteristics. Also widely used for RF chokes in transceiver equipment.



FX H core

A thermoplastic impregnated with ferrite dust, use for FM input transformers, baluns etc. Available as former only, or with windings:

- FXH1 3turns primary 6 turns secondary for FM portable input stages
- FXH2 3 turns primary, 6 turns secondary with centre tap for 300 ohm/ 75 ohm antenna matching baluns
- FXH0 ferrite H core former only [5t for 0.5uH]

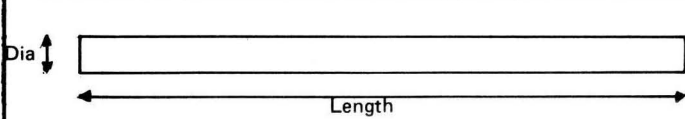

Ferrite rod 3/8" diameter (9.5mm)

- F14 material 150kHz to 2MHz:
- FRA 5.5" (140mm)
- FRB 6.5" (160mm)
- FRC 7" (175mm)
- F16 material 500kHz to 12MHz:
- FRD 8" (200mm)

**Ferrite rod coils** the best quality Electronic Techniques manufacture

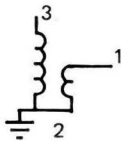
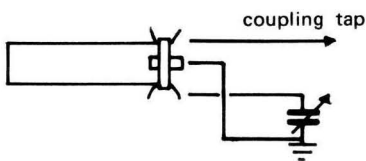

MW antenna coil MWC1  
Flush on FRC L= 280uH  
1cm down FRC 370uH  
tapped to suit bipolar input stages  
(HA1197/CA3123E/TBA651 discrete)

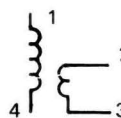
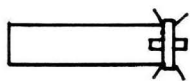

MW antenna coil MWC2  
Flush on FRC L= 330uH  
1cm down FRC 420uH  
With separate coupling winding - which may be joined (3 to 4) to form simple tap. Suitable for all IC inputs specifically TDA1083/TDA1220/TDA1090  
Not suited to bipolar discrete inputs

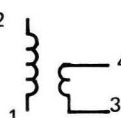
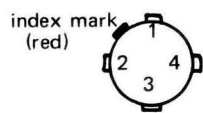
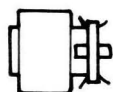

LW antenna coil LWC1  
Use with 68pF parallel capacity  
Flush on FRC L= 3mH  
1cm down FRC 4.45mH  
Suitable for bipolar and IC circuitry

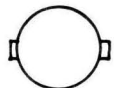
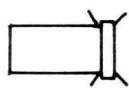

Coupling coil FRCC1  
External antenna coupling coil for FR assemblies  
Flush on FRC L= 100uH  
1cm down FRC 140uH

**Polyvaricon tuning capacitors**

2A20ST7  
2x266pF + trimmer Cs on both sections  
the standard AM tuning gang

CY2-2217Z  
2x335pF AM section + trimmers  
2x20pF FM section + trimmers

Standard UK / Europe AM/FM tuning gang for portables

CY2-3217PX  
2x335pF AM section + trimmers  
3x20pF FM section + trimmers on 2

For superior quality FM portables and low cost stereo tuner applications

The FM section gangs may also be used for SW bandspread where main tuning is preset with a capacitor across the RF and osc coils

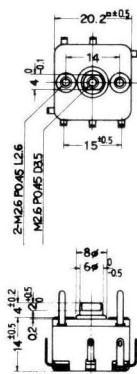
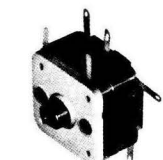

2A-20ST7

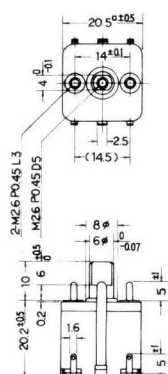

CY2-2217Z

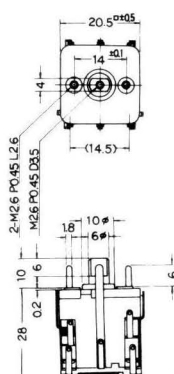

CY2-3217PX

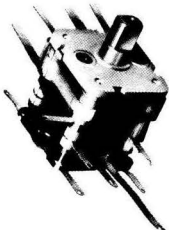

## 13K

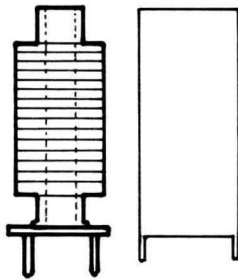

Screen can

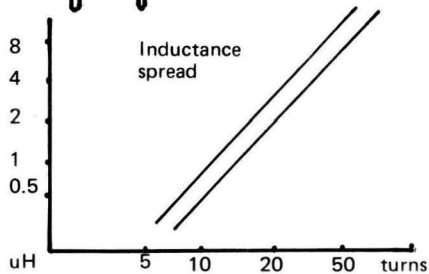

## The 13k series

The 13K is a 13mm square based coil, with a 5mm diameter centre former with integral spiral molding in which the windings are held with exceptional rigidity. Two slugs provide adjustment for double coils, if required, with the access available from either end. The wire diameters may vary from between 0.5 and 1mm - though the larger the wire diameter used, the larger the  $Q_u$  available.

## Characteristics:

Torque of core 10-150 gm.cm  
Dielectric strength 500v between each coil and the coil and case

Initial symbol	Frequency range	Temp coef	$Q_u^*$	Adjustment range
V4FCN	2-20MHz nom	220±60ppm	70	L± 10%
V4LCN	2-20MHz	150±60ppm	50	..
V4VMN	30-60MHz	0	100	..

The 13k parameters above are given for wire of 0.4mm diameter. For HF oscillator applications, it is recommended that as little of the core as possible be employed in the tuning of the coil, since the drift of the coil assembly is largely a function of the ferrite employed.

13k formers supplied will have windings already - since these are sold primarily as "dead stock" items. Large quantities of formers are not available other than as ready wound items ie we cannot supply piece parts only.

## 10K

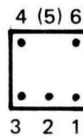
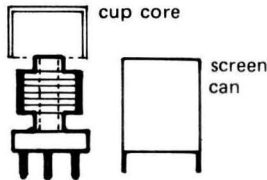

Base

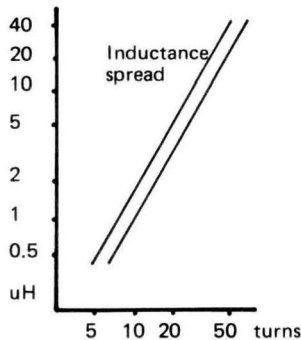

## The 10k series

The 10k is a 10mm square base coil, with 3mm diameter former, with integral spiral molding in which the windings are held rigidly. A single slug core is provided for adjustment, accessible from either end of the former body.

Conventionally, the primary winding should be placed between pins 1 & 3, with pin one being 'earthy' wrt RF. The tap on the primary at pin 2, with secondary or coupling windings between pins 4 & 6

## Characteristics:

Torque of core 10-150 gm.cm  
Dielectric strength 100v between windings and case, and between primary and secondary

Initial symbol	Frequency range	Temp coef	$Q_u$	Adjustment range
KAN/KAC †	2-11MHz	220±100 ppm	100	F± 10%
KXN/KXC †	11-45MHz	..	100	..
KEN/KEC †	45-100MHz	..	80	F± 5%
KACA	2-11MHz	150±100ppm	80	..
KXCA	11-45MHz	..	80	..
KECA	45-100MHz	..	70	..

† Include ferrite cup core

## 10E

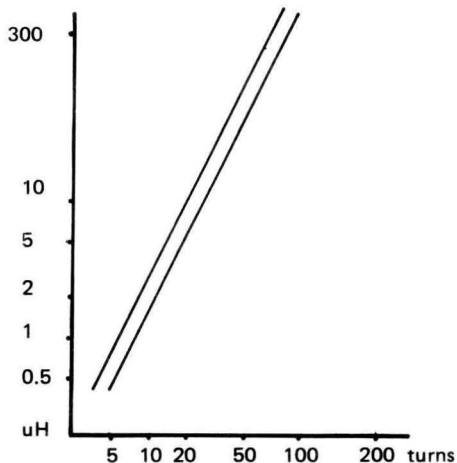
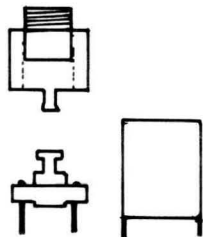

## The 10E/10EZ series

The 10E and 10EZ may be considered as the same thing for the purposes of this description - in practise the 10E has the threaded adjustable cup core fixed in an extension of the base - whereas the 10EZ types have the threaded core held in a removable plastic holder, that snaps into place, after the winding has been fixed on the central ferrite bobbin core.

These coils are the basic types for use in the range 100kHz to 15MHz and offer exceptional  $Q$  combined with small size. The actual inductance is adjustable over as much as ±50% of its nominal value, though  $Q$  and TC may suffer if taken to such extremes. For the majority of amateur applications, the 10EZ style is probably one of the most effective coil systems to employ, combining high  $Q$ , small size, wide adjustment range and ease of winding.

The formers supplied are likely to have existing windings, and in some instances, internal capacitors, which may be disabled by simply breaking with a small screwdriver. As with the 13k, we are unable to supply entirely blank formers in quantity.

## Characteristics:

Torque of core 40 - 500 gm.cm  
Dielectric strength Depends on wire insulation quality. Max 100v between case and windings

Initial symbol	Frequency range	Temp coef	$Q_u$	Turns/uH
RL /YL	0.2 to 1MHz	750±120	70	172/640
RM/YM	..	..	110	165/640
RZ/RH/YH	..	..	140	148/640
154P	2 to 15MHz	220±100	60	14/4.3
154A	..	..	110	14/4.3
RW /YX	0.5 to 2MHz	150±100	110	85/290

For details of dimensions, and further descriptions, please refer to the general standard coil information sections of this catalogue

Passive components

Resistors, presets, capacitors

Colour code

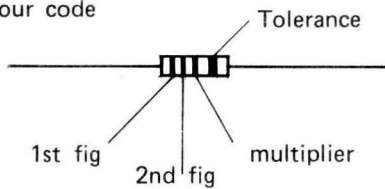

Available in E12 series  
All either Iskra, mullard or piher 0.25 - 0.33 W only  
10E to 10M ohm

**RESISTORS**

Resistor identification

colour	figure	multiplier	tolerance
black	0	x1	
brown	1	x10	
red	2	x100	2%
orange	3	x1000 (1k)	
yellow	4	x10000 (10k)	
green	5	x100000 (100k)	
blue	6		
violet	7		
grey	8		
white	9		
silver		x0.01	10%
gold		x0.1	5%



colour code (Iskra only)

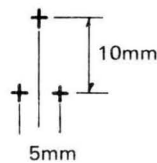

In keeping with our general wireless specialization, the passive components offered here are chosen from a restricted range to suit radio applications, where small size and low power are the main criteria.

The presets are all either Iskra, Mullard or Piher 10mm types, with adjustment from above/below. Types PN10V etc.

Values 100E 470E 1k0 1k5 4k7 10k 25k 47k 100k 470k 1M 2M5

Also diode law 22 turn presets for varicap tuning etc 100k only

**PRESET POTENTIOMETERS**

The electrolytic capacitors are selected as values most commonly appearing in radio circuits, And in many applications, values of electrolytic capacitors are tolerant of very broad variations.

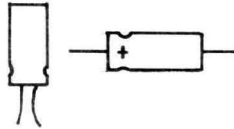

Value	Voltage	Type
0.22	16v	Vertical tantalum bead
0.33	16v	..
0.68	16v	..
1.0	16v	.. and vert. al. electrolytic
2.2	16v	..
10	16v	.. and vert al. electrolytic
22	6.3v	..
22	10v	.. and vert al. electrolytic
33	6.3v	..
100	3v	..
100	10v	..
47	16v	Vertical alumin electrolytic
100	16v	Horiz ..
1000	16v	Horiz ..
1000	25v	Horiz ..
3300	25v	Horiz ..
4700	16v	Horiz ..
4.7	16v	Ver t ..

**ELECTROLYTIC CAPACITORS**

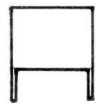

Polyester and polycarbonate capacitors, 10mm lead spacing, 100v working 10% or better

10 nF	22 nF	100nF	220nF	470nF
Mylar 10%, 5mm spacing				
10nF	20nF	33nF	220nF	470nF (220 & 470 nF 15mm spacing)

[1nF = .001uF = 1000pF]

**NON ELECTROLYTIC CAPACITORS**



Ceramic capacitors: Mullard plate and misc. disc types

2p2	3p3	4p7	8p2	10p	15p	18p	22p	27p	33p	39p	47p	56p	68p	82p
100p	150p	220p	270p	330p	470p*	1000p*	10000p*	2200p**	3300p**	4700p**				

\*high K coupling/decoupling types only

\*\* Med K

These ranges have been selected for small size, efficient RF performance and lead spacing of either 2.5 or 5mm (max)

**CERAMIC CAPACITORS**

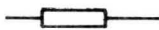

Polystyrene capacitors

10p	27p	47p	220p	270p	330p	390p	470p	820p	1000p	1200p	1500p	2200p
3300p	4700p	5600p	10000p	2700p	3900p							

Generally 10% or better tolerance, 100v DC working

**POLYSTYRENE CAPACITORS**

Please note that these passive components are not intended to form the basis of a comprehensive range, but to complement RF semiconductors from our range. We regret we cannot offer quantity pricing on the items shown on this page, since they are primarily offered as a service to our hobbyist/enthusiast customers.

The minimum order for items from this page is £2 - as we wish to encourage serious enthusiasts to stock up on values that commonly appear in our circuits. We cannot guarantee to supply identical types at all times, since we may be obliged to take other manufacturers product to ensure continuity. However, we always endeavour to supply items of similar overall dimensions and lead spacing.

Remember Decoupling 400kHz to 15MHz : use 10,000pF 15MHz to 75MHz : use 4700pF  
75MHz to 125MHz : use 2200pF 125MHz to 400MHz: use 1000pF

For frequency determining applications, avoid the use of ceramic capacitors above 100pF

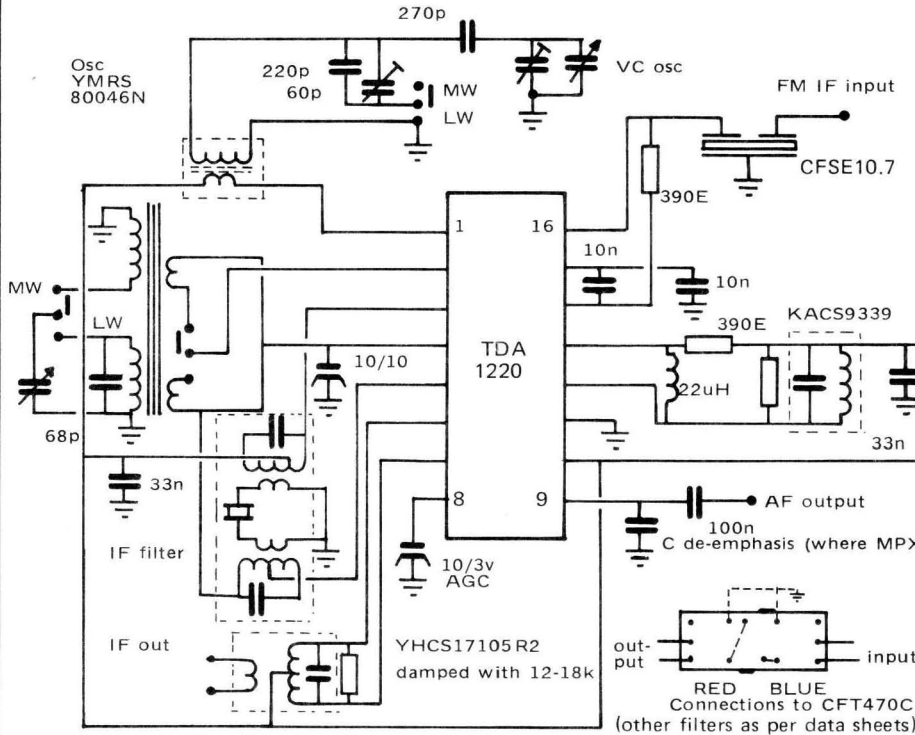

After a lean stretch in radio IC presentations, we have suddenly been presented with a whole new family of two terminal oscillator, fully balanced mixer devices. The TDA1083, TDA1062, TDA1090 and now the TDA1220.

Fortunately, the ranges are complementary rather than competitive, and so each has a set of particular features. The TDA1220 features almost entirely separate internal arrangements for AM and FM, basically switching the oscillator off to 'kill' AM, and sharing the audio output pin. The device cannot offer simultaneous AM and FM without external modification.

In fact, this latest batch have many features not found in some ICs previously considered as specialized 'communication' devices - like the famous Plessey SL600 series.

Almost any of the range of TOKO IF filters will match into the TDA1220 - types recommended for UK broadcast reception are based on 470kHz IF, since as you may know, radio four London is broadcast on 910kHz. Exactly twice the 455kHz standard that is used outside Europe. This is really a fairly minor inconvenience, especially where a fully balanced mixer is employed, as in this IC.

Antenna assembly: AM MWC2/LWC on rod of desired length (9.5mm dia)

**The TDA1220**

Many internal features of the TDA1220 resemble the TDA1083 - the balanced mixer, the oscillator - and so it is not surprising that this IC exhibits the same type of versatility, with operation of all AM functions in excess of 40MHz. The oscillator coil requires a slightly higher impedance than with the TDA1083, which means more coupling turns - the oscillator Z is given as being 5k, and for the higher SW bands, the entire tank circuit may be used instead of the coupling winding. The additional capacity aquired in this fashion is only 5pF, and so can easily be accounted for in the trimmer ranges. However, once again the oscillator amplitude is controlled via the AGC line,, and so SSB performance at frequencies above 5MHz is not particularly good. SSB may be derived in the same way as with the TDA1083 (see the "one chip communications receiver"), or it may be achieved with a separate MOSFET product detector.

The IC exhibits a fairly startling AM sensitivity, with 0.5uV of AM being discernible when fed directly to the chip at 1MHz. At 30MHz, this rises to about 2uV, which is nevertheless quite a substantial amount of gain, considering most of it takes place at a single frequency. The next word is therefore a cautionary one concerning stability - the IF may become unstable, particularly in the MW at 21F (2.470kHz for example - 940kHz.) In fact, the 455kHz is rather better, since the AGC reduction when tuned to Radio 4 tends to mask the low frequency burbles. The answer is easily enough found, damp the input coupling on the IF filter until it stops - usually about 1.5k does the trick - and in many applications, this spot interference is not really much of a problem, and can be ignored in favour of using as much gain as can be achieved.

What all this adds up to is a superb device for a variety of broadcast and communications applications. In fact, the DC coupling of all the internal stages implies that the IC is ideal for use as a synchronous SSB receiver, with AF being filtered from the mixer output, and then amplified in the IF amp, used at audio. The AGC thus derived would be audio referred - which is what you need for best SSB, and the access to the AGC time constant at pin 8 permits tailoring of this response to suit the desired attack and hang characteristics. Not much has yet been said about the FM section, and this is basically a cut down 3089, minus muting, and AFC outputs. The AFC may be derived (and in the usual sense) from the audio output - the detail given for the TDA1083 shows the method to use for the TDA1220. The absence of a muting facility shouldn't matter in the types of applications anticipated for this device, which are mainly in the areas of car radio, and the great reviving area of a simple mains power "table radio" (brought about by the massive increase in battery prices, as it costs almost 100 times less to power from the mains) and of course, the clock radio - where the added sophistication of an easily made SW feature is a big plus in many areas of the world. In non-stereo applications, the IF should have sufficient gain when driven directly from the tuner output (AT3302 for example - but since the FM section does possess potentially HiFi specifications, the use of an IF preamp will raise the general off-station noise to an uncomfortable level, and a noise mute is a necessary feature. An FET gate would permit a smoother mute transition than the snappy type employed inside the 3089 family.

Specifications		Min	Typ	Max	Units	Comments
Parameters	Test conditons					
Supply voltage		4		18	v	No internal shunt regulator, so OK for direct mobile power
Supply current	AM at Vcc 9v		15		mA	Not quite the same league as the amazing TDA1083
	FM at Vcc 9v		20		mA	
Input impedance	pin 2		5k/10pF			Use MWC2 coil
Input impedance	pin 5		2k/5pF			
Output impedance	pin 3		50k/3pF			
Oscillator	pin 1		5k/5pF			
Detector	pin 6-7		20k/5pF			
AM input sensitivity	pin 2 S/N 26dB at 1MHz		10		uV	Comms. use down to 0.5uV
Best S/N	10mV RF input		56		dB	
AGC range	AF level shift 3dB		75		dB	good
Recovered audio	1mV in, 80% mod at 1kHz		200		mV	
Distortion	1mV in, 30% mod at 1kHz		0.5		%	
Overload	THD 10% at 80% mod		150		mV	very good for AM
Local oscillator dropout		2			V	as TDA1083
FM input limiting voltage	10.7MHz		25		uV	
AM rejection	Input 200uV+		45		dB	
Ultimate S/N	Input 10mV		65		dB	
THD	Full 75kHz dev. at 1kHz		1.0		%	
Recovered audio	Input 1mV, 75kHz dev. at 1kHz		220		mV	

(Recovered audio is a function of detector coil damping)

**Bipolar**

NPN types:

Type	Similar to	V <sub>ceo</sub>	h <sub>fe</sub> @ I <sub>c</sub> (mA)	f <sub>t</sub> @ I <sub>c</sub> (mA)	P tot @ 25°C	I <sub>c</sub> Max (mA)
ZTX107	BC147, BC107 etc	50	125/500 2	150 10	300mW	100mA
ZTX108	BC148, BC108 etc	30	125/500 2	150 10	300mW	100mA
ZTX109	BC149, BC109 etc	30	240/900 2	150 10	300mW	100mA
ZTX413	BC413	30	300/800 2	150 10	300mW	100mA low noise types
BF194	BF594	20	65/220 1	260 1	250mW	4dB NF @ 100MHz
BF195	BF595	20	35/120 1	200 1	250mW	4dB NF @ 100MHz
BF241		40	36/125 1	400 1	300mW	1.6dB NF at 100MHz
BF395	BF195	30	35/125 1	180 1	350mW	1.7dB NF at 1MHz
BF224		30	30/85 7	800 7	360mW	150mA RF amp/ IF amp
BF274		20	70/250 1	700 1	200mW	100mA use for osc/mixer
40238		30	40/70 7	400 7	360mW	100mA shielded RF amp/osc

Type	Similar to	V <sub>ceo</sub>	h <sub>fe</sub> @ I <sub>c</sub> (mA)	f <sub>t</sub> @ I <sub>c</sub> (mA)	P tot @ 25°C	I <sub>c</sub> Max (mA)
ZTX212	BC212	50	60/400 2	200 10	500mW	200mA
ZTX213	BC213	30	80/550 2	200 10	500mW	200mA
ZTX214	BC214	30	140/550 2	100 10	500mW	200mA

PNP types:

**Power types**

NPN

ZTX451		60	50/150	150	150 50	1000mW	1A	
BD515		45	60/350	150	160 200	10W	2A	12.5°C/W
BD165		45	40/80	150	6 500	20W	1.5A	6.25°C/W
BD377		60	60/150	150		25W	2A	5°C/W
BD535		60	25min	2A	3 250	50W	4A	2.5°C/W
BD609	Hi voltage 3055	80	30/50	2A	1.5 1A	90W	10A	1.39°C/W

PNP

ZTX551		60	50/150	150	150 50	1000mW	1A	
BD516	comp to BD515	45	60/350	150	125 200	10W	2A	
BD166	comp to BD165	45	40/80	150	125 200	20W	1.5A	
BD378	comp to BD377	60	60/150	150		25W	2A	
BD536	comp to BD535	60	25 min	2A	3 250	50W	4A	
BD610	comp to BD609	80	30/50	2A	1.5 1A	90W	10A	

**MOSFETs**

	V <sub>dss</sub>	G1/2 to source V	Power Gain at	MHz	Noise figure	I <sub>Dss</sub>	
BF900	20	±6	20dB	200	2dB typ	10mA typ	RF/Mixer
MEM680	25	±6	21dB	200	3.0dB typ	12mA typ	RF/Mixer
MEM616	25	±6	18dB	200	3.5dB typ	15mA typ	RF/
40822	18	±3	24dB	100	2.0dB typ	15mA typ	FM RF
40823	18	±3	18dB conv	100/10.7	2.5dB typ	15mA typ	FM mixer

**J FETs**

BF256	TIS88A, 2N5245	30	14dB gain at 800MHz, 1dB NF at 100MHz	DC to 1000MHz general purpose FET 'N'
E176	2N3820	30	V <sub>gs</sub> (off) 1-4 v, R <sub>ds</sub> 250 ohms	General purpose P channel gate/switch

**MISC**

TIS43	general unijunction	30
-------	---------------------	----

**Base connections**

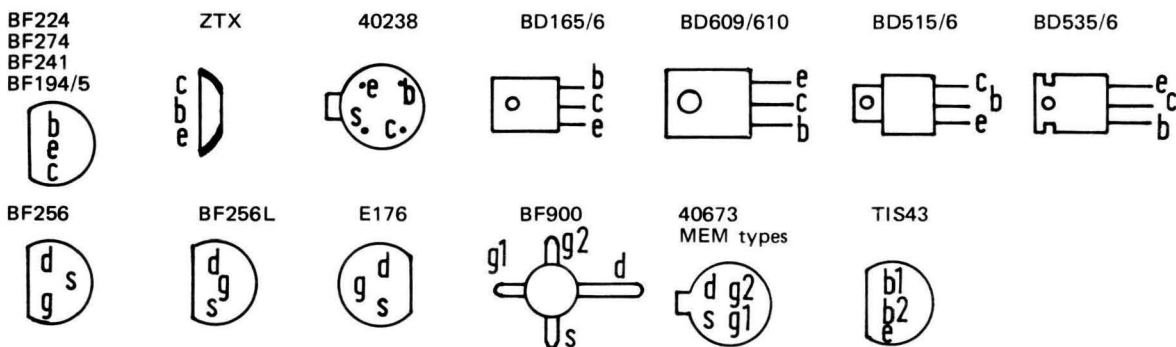

**Selecting semiconductors for RF**

Of the discrete types, the best rule of thumb when selecting semiconductors for RF applications is to avoid devices with a high  $f_t$  in common base applications, and get the best  $f_t$  devices for oscillator applications. The BF194/5 are amongst the most widely used general purpose RF/IF amplifiers, the BF274 is an excellent mixer/oscillator. The BF224 is a useful amplifier and multiplier in transmit applications, and the 40238 should be used where a screened device is necessary. For a full appreciation of small signal RF design, reference must be made to the Y parameters, and their application - which are beyond the scope of this section of the catalogue. For the majority of RF amplification applications, the dual gate MOSFET is one of the most effective, and also one of the easiest devices to work with. The high input impedance allows simple matching to tuned circuits, and the AGC capability of G2 is well known. The JFET is a particularly good oscillator - so good that almost any JFET common source configuration will require neutralizing to prevent unwanted oscillation taking place. In common gate configuration, stability and bandwidth are improved, but maximum gain reduced. One of the most effect RF amplifier circuits is the cascode:

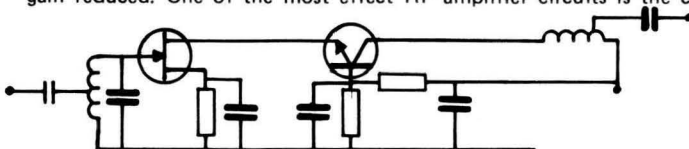

This configuration has very low feedback capacitance, hence good stability, combined with the gain of a common source stage and an excellent noise figure. Either reverse or forward AGC may be applied, with a Max gain at  $V_{agc} \approx 0v$ . This type of circuit is well suited to 'preamp' and preselector circuits where gain control may be a manual function, since the AGC range is not as good as that of the standard dual gate MOSFET stage.

**TDA1061**

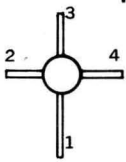

- \*Constant impedance
- \*Up to 1000MHz

V<sub>agc</sub>: reducing increases signal attenuation

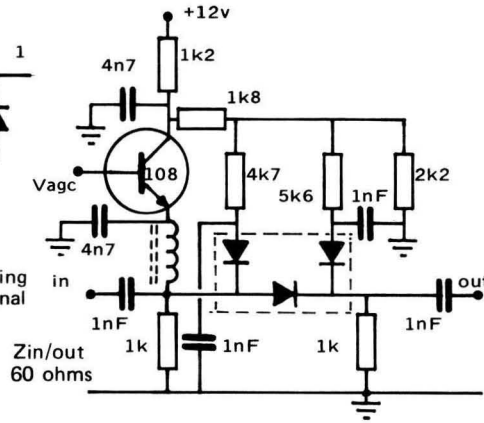

Pin diode attenuators are increasingly popular in all forms of radio receiver - particularly TV tuners. The TDA1061 is a constant impedance network, suitable for either manual or automatic gain control systems. The BA479 is a single diode, suitable for most PIN diode attenuator and switching applications.

	TDA1061	BA479
Max reverse voltage	30v	25v
Max forward current	50mA	50mA
Forward voltage at 50mA	1.2V	
Max reverse current	500nA	400nA
Forward resistance at 10mA	5Ω	0.7Ω
Noise for 1% cross mod	1V	
Attenuation 40MHz to 1GHz	45dB	V <sub>agc</sub> 1-2V 1.5dB V <sub>agc</sub> 4-5V

Careful construction is necessary to obtain optimum performance

BA479/  
BB105 package



**Varicap diodes**

Type	V <sub>r</sub> max	C@V <sub>r</sub> 2v	R <sub>series</sub> Ω	Cap ratio	Q	Applications
BB105B	28v	11-16pF	0.7	4.5		UHF tune/afc
ITT210	20v	16-18pF	0.3	4		afc to 1GHz
BA121	30v	8-12pF	0.9	2.5	600/30	afc to .6GHz
BA102	20v	38-42pF	0.35	4		vhf tune/afc
BB104B	30v	48-50pF	0.3	3.5		vhf tuning
MVAM2	28v	280/380*		15	150min	lf/hf tuning
MVAM115	18v	440/560		15	150min	lf/hf tuning
MVAM125	28v	440/560		15	150min	lf/hf tuning

\*V<sub>r</sub> 1v for MVAM series. The MVAM2 is a double diode matched to 1.5%  
KV1210 20v 440/560 15 200min lf/hf tuning††  
†† Triple diode, matched to within 1½% per section

When using varicap diodes, remember that power supply stability - and purity - is paramount. Noise on the tuning voltage line may be picked up in a number of ways, and remember that such lines are frequently high impedance, and so prone to interference from mains leads, transformers etc. Use screened lead where necessary, and do not decouple with large capacitors, since this will simply slug the tuning rate excessively. Varicap tuning is ideally suited to remote tuning applications - mast head preamps, HF antenna tuners etc., in which case a low impedance tuning voltage source is best eg emitter follower output.

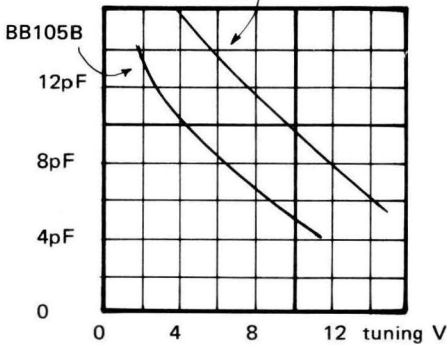

BA121

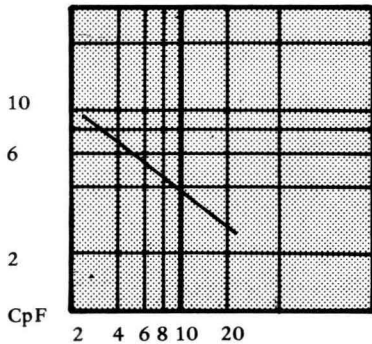

BA102

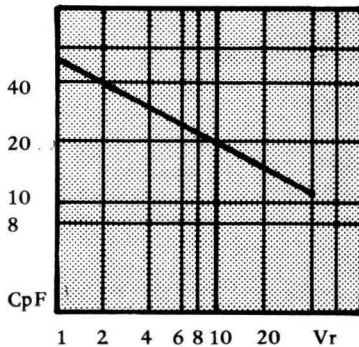

BB104 B

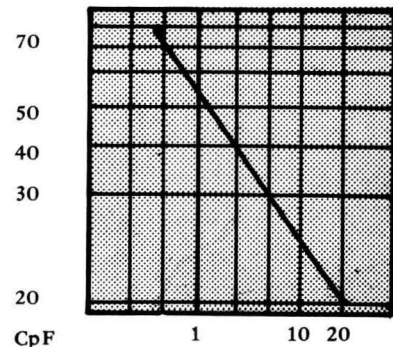

MVAM2

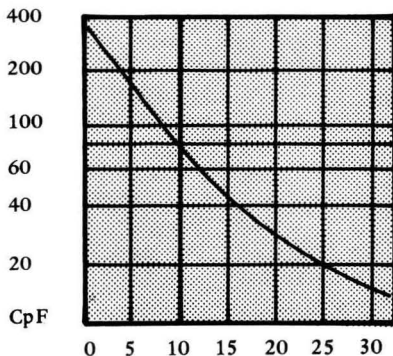

MVAM115

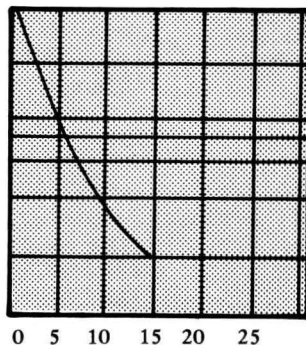

MVAM125

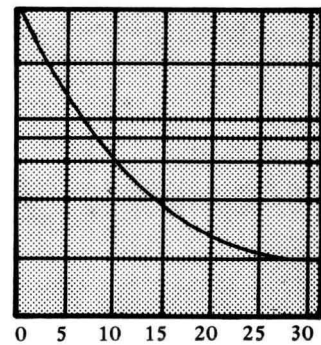

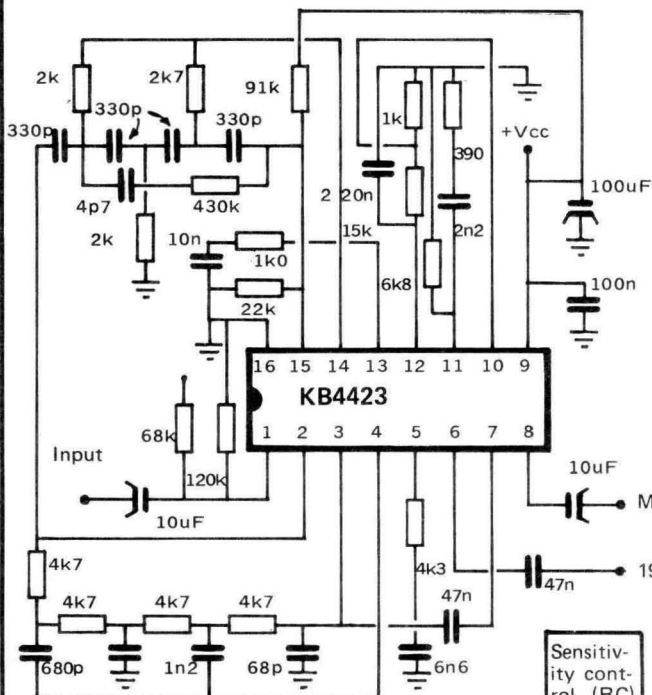

**Specifications**

Parameter	min	typ	max	unit
Supply voltage	8	12	18	V
Power dissipation at 25°C			540	mW
Storage temp range	-55	20	125	°C
Operating temp range	-20	20	+70	°C
Current consumption			25	mA
Voltage gain	-1	0	+1	dB
Maximum output voltage K1%	1.5			V rms
Distortion (THD) at 0.5v rms out			0.1%	(K)
Gate time, pulse 100mV/1uS@1kHz		25		uSec
Noise input sensitivity	60			mV
Input impedance		30		kΩ

Special notes: The operational temperature range is specifically characterised outside usual commercial limits for operation in car radio environments.

Certain of these stated parameters are determined by the external components chosen - and are thus "programmable"

19kHz output to pin11 of MC1310/CA1310/HA1156/KB4400 etc  
pin13 of HA1196, pin12 of HA11223, pin13 of HA11227

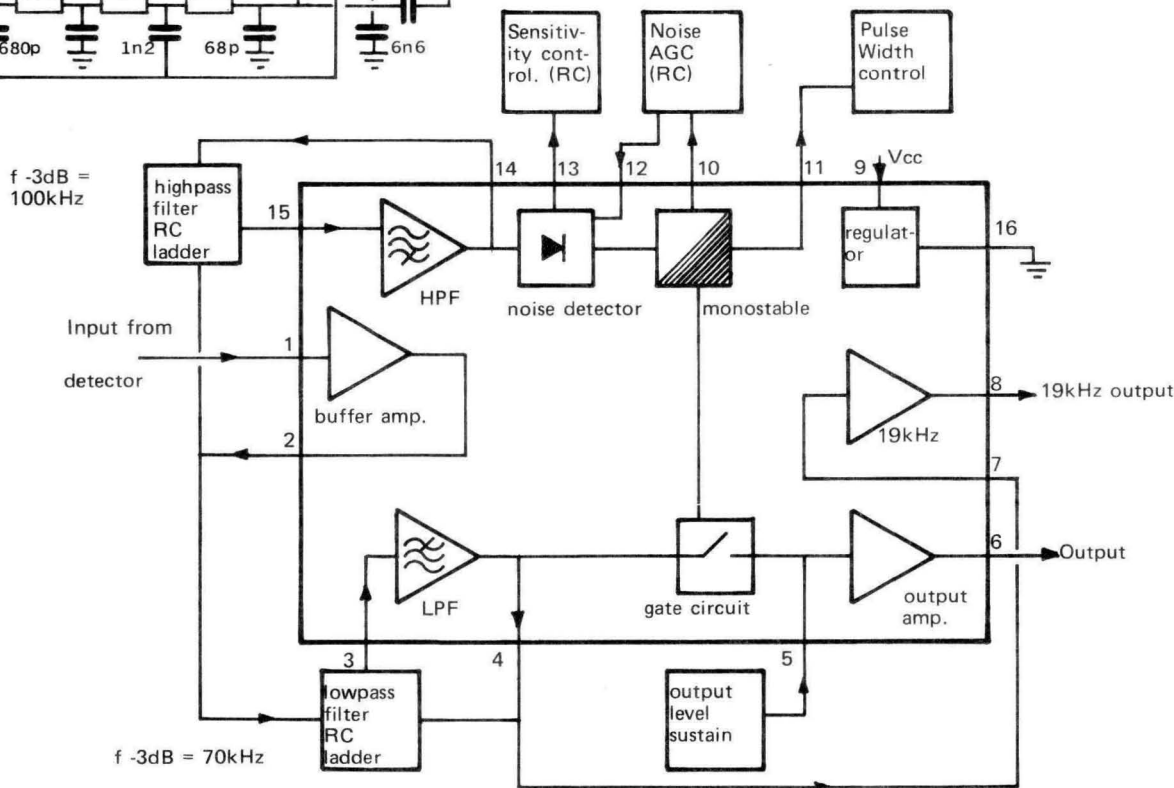

The KB4423 is a new IC from TOKO/Kyodo, primarily for auto noise suppression in car radio - where impulse interference is the prime cause of reception degradation. The main problem is usually other vehicle ignition systems, and is thus effectively beyond treatment in any other fashion. The blanker simply substitutes a period of "nothing" for the duration of the impulse. However, this approach is also suitable for applications in AM, record scratch conditioning and fixed HiFi (to eliminate thermostat, and general mains switching noises. All filter and time constants are externally accessible, and thus re-programmable by the designer.

In the application board 11219B, two additional facilities are incorporated for defeating the gate operation, thus bypassing the blanking system, and for operating an LED lamp via the monostable pulse width control - thus providing a visual confirmation of the operation of the circuit. Bearing in mind the rapid operation of the pulse and timing circuits, it is essential to decouple all power lines carefully, otherwise impulse noise may be propagated down supply lines to the decoder/audio stages.

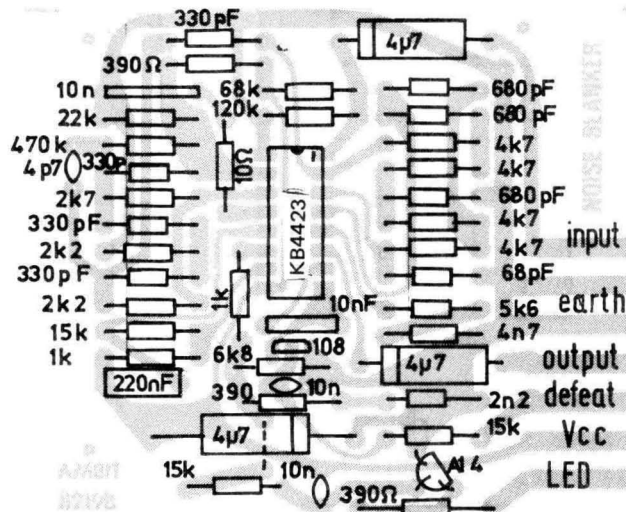
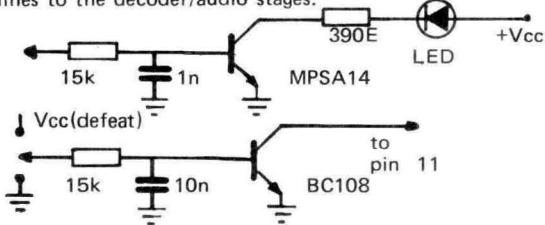

**NT3302UG AM 2 Section · FM 3 Section**

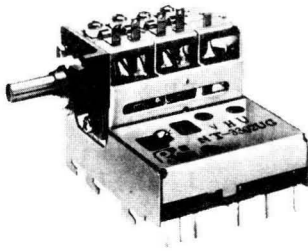

Transistors  
J FET; 1ea  
Bipolar; 2ea

**Circuit**

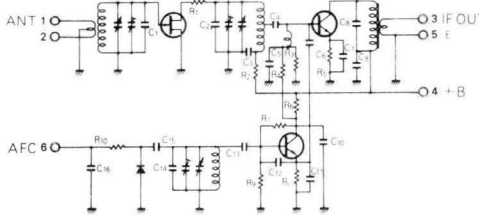

**Dimensions**

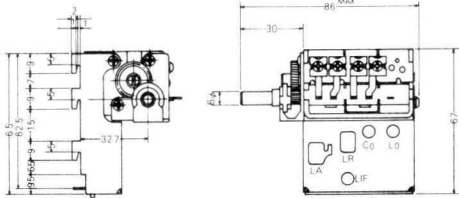

There are two basic types of TOKO mechanically tuned band 2 tunerhead. The AT gang and NT gang version. Both types are supplied with a 3:1 reduction drive - and they are electrically compatible - though with minor dimensional changes. The AT being some 10mm wider. Please note that both AM gangs are the same capacity swing, and both come complete with trimmers for the osc and antenna sections

**Specifications**

Tuning Range	87 - 109MHz
Supply Voltage	+ 9VDC
Current	18mA MAX
Input Impedance	300Ω
Output Impedance	300Ω
Power Gain	25dB MIN
Gain Difference with Band	4dB MAX
Image Rejection	45dB MIN
IF Rejection	50dB MIN
Spurious Rejection	50dB MIN
IF Bandwidth	200kHz MIN
Frequency VS. Lower Voltage	±150kHz MAX
Thermal Drift	±150kHz MAX
Osc. Stop Voltage	6.3V MAX
Noise Figure	8dB MAX
Large Signal	120dB MAX
Calibration Shift at Band Edges	±200kHz MAX
Calibration Shift within Band	±300kHz MAX
AFC Operation	±120kHz MIN
Spurious Radiation (FCC)	34dB MAX

The AT and NT tuners are ideal for mass production AM/FM tuners where performance and low cost are important. The current drain is in fact sufficiently low for the units to be considered for portable applications in conjunction with an IC such as the TDA1083, although the general standard of performance is generally far in excess of the requirement of portable radio.

The AM gang is particularly stable, and suitable for wide range broadcast receiver uses, including the shortwave.

**Calibration Data**

**NT-3302UG**

Tuning R. (%)	0	4.1	12.8	21.4	30.0	38.6	47.3	56.0	64.9	73.7	82.7	92.0	98.2
Frequency (MHz)	87	88	90	92	94	96	98	100	102	104	106	108	109
Allowance (kHz)	± 200		± 300										± 200

The Larsholt 8319 is a PC mounted varicap tuner that features low noise combined with high gain. This unit is employed in the famous 7252 tuner set, where all HiFi functions of tuning meter, signal level meter etc. are fully exploited.

The AFC provision must be made through the main tuning voltage, though a provision is made for ratio detector AFC on the oscillator tuned circuit.

This unit is recommended for use in OEM designs, and is readily available in quantity.

**Specifications**

Frequency range	2.3 to 18v bias	87.5-108MHz
IF output frequency	10.7MHz nom.	
Supply voltage/current	12v/25mA	max ripple 0.15mV pp
Max ripple on tuning voltage	3uV pp	
AGC voltage for max gain	+4.5V dc	
Input impedance	75 & 300 ohms	
IF output impedance	150 ohms	
Power gain / noise figure	32dB /5dB	
Image rejection/IF rejection	56dB /80dB	
Radiation from antenna	less than 500uV	

Terminations A/B:75ohms input - A/C:300ohms input - B:Ground - D:AGC - E:V supply  
F:Ground - G:IF output - H:Ground - I:Ratio detector AFC otherwise ground - K:tuning bias

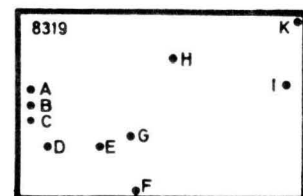
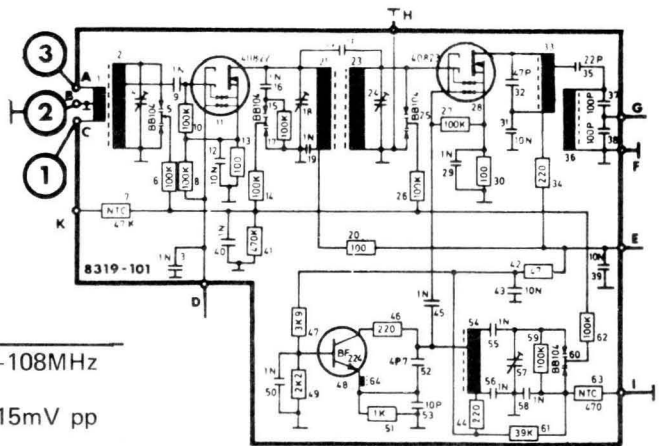

**EF-5603**  
VARACTOR-TUNED

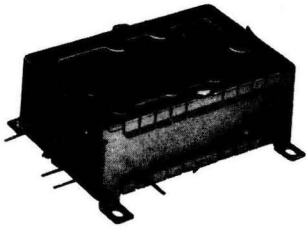

Tuned Circuits  
RF:4 Osc:1

Transistors  
MOSFET: 1 ea  
Bipolar:3 ea

Dimensions

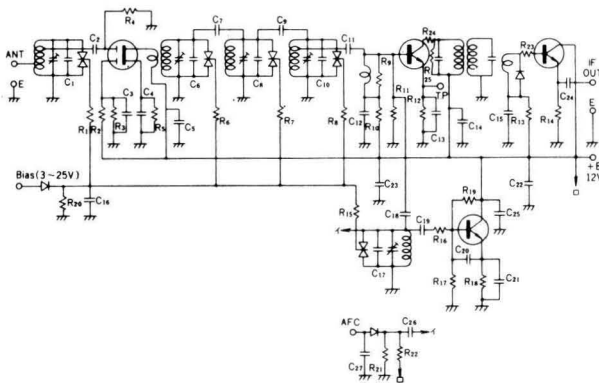
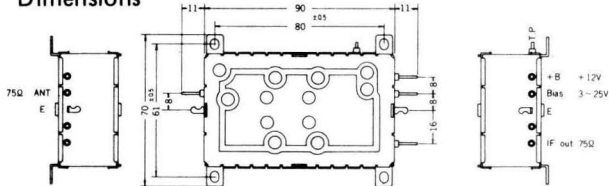

SPECIFICATIONS

- Tuning Range 87-109 MHz
- Supply Voltage +12 VDC
- Current 17 mA MAX
- Input Impedance 75 ohms
- Output Impedance 75 ohms
- Power Gain 30 dB MIN
- Gain Difference with Band. 4dB MAX.
- Image rejection 90 dB MIN.
- IF Rejection 90 dB MIN.
- Spurious Rejection 90 dB MIN.
- IF Bandwidth 300±120 kHz MIN.
- Frequency VS. Lowered Voltage ±50 kHz MAX.
- Thermtl Drift. ±100 kHz MAX.
- Osc. Siop Voltage 9V MAX.
- Noise Figure 7 dB MAX.
- Galipration Shift at Band Edges ±200 kHz MAX.
- Calibration Shift within Band ±300 kHz MAX.

CALIBRATION DATA

TUNING VOLTAGE, V	3.00	3.29	3.94	4.71	5.64	6.77	8.15	9.83	11.93	14.57	17.94	22.31	25.00
FREQUENCY, MHz	87	88	90	92	94	96	98	100	102	104	106	108	109
ALLOWANCE, )	±200												
	±300												
	150 ±200												

**EC-3302**  
VARACTOR-TUNED

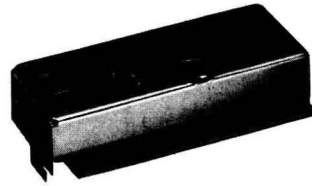

Tuned Circuits  
RF:2 Osc:1

Transistors  
J FET : 1 ea  
Bipolar : 2 ea

Dimensions

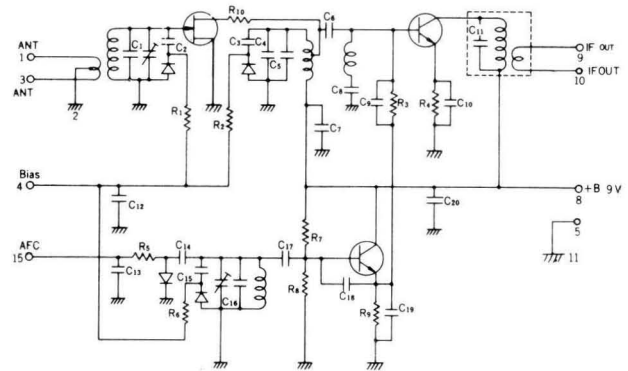
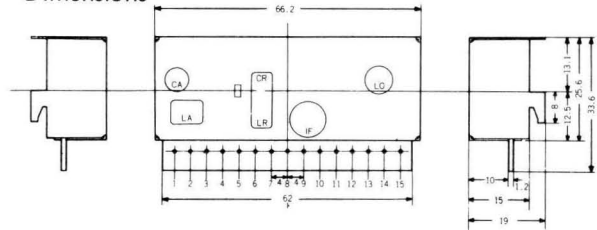

SPECIFICATIONS

- Tuning Range 87-109 MHz
- Supply Voltage +9 VDC
- Current 17 mA MAX.
- Input Impedance 300 ohms
- Output Impedance 300 ohms
- Power Gain 22 dB MIN.
- Gain Difference within Band 4 dB MAX.
- Image rejection 45 dB MIN.
- IF Rejection 50 dB MIN.
- Spurious Rejection 50 dB MIN.
- IF Bandwidth 200 kHz MIN.
- Frequency VS. Lowered Voltage ±150 kHz MAX
- Thermal Drift, ±150 kHz MAX.
- Osc. Stop Voltage 6.3V MAX.
- Noise Figure 8dB MAX.
- AFC operation ±120 kHz MIN.

CALIBRATION DATA

TUNING VOLTAGE, V	2.43	2.64	3.13	3.72	4.41	5.23	6.17	7.29	8.63	10.32	12.74	17.00	20.78
FREQUENCY, MHz	87	.88	90	92	94	96	98	100	102	104	106	108	109
ALLOWANCE, KHZ	700 MAX												

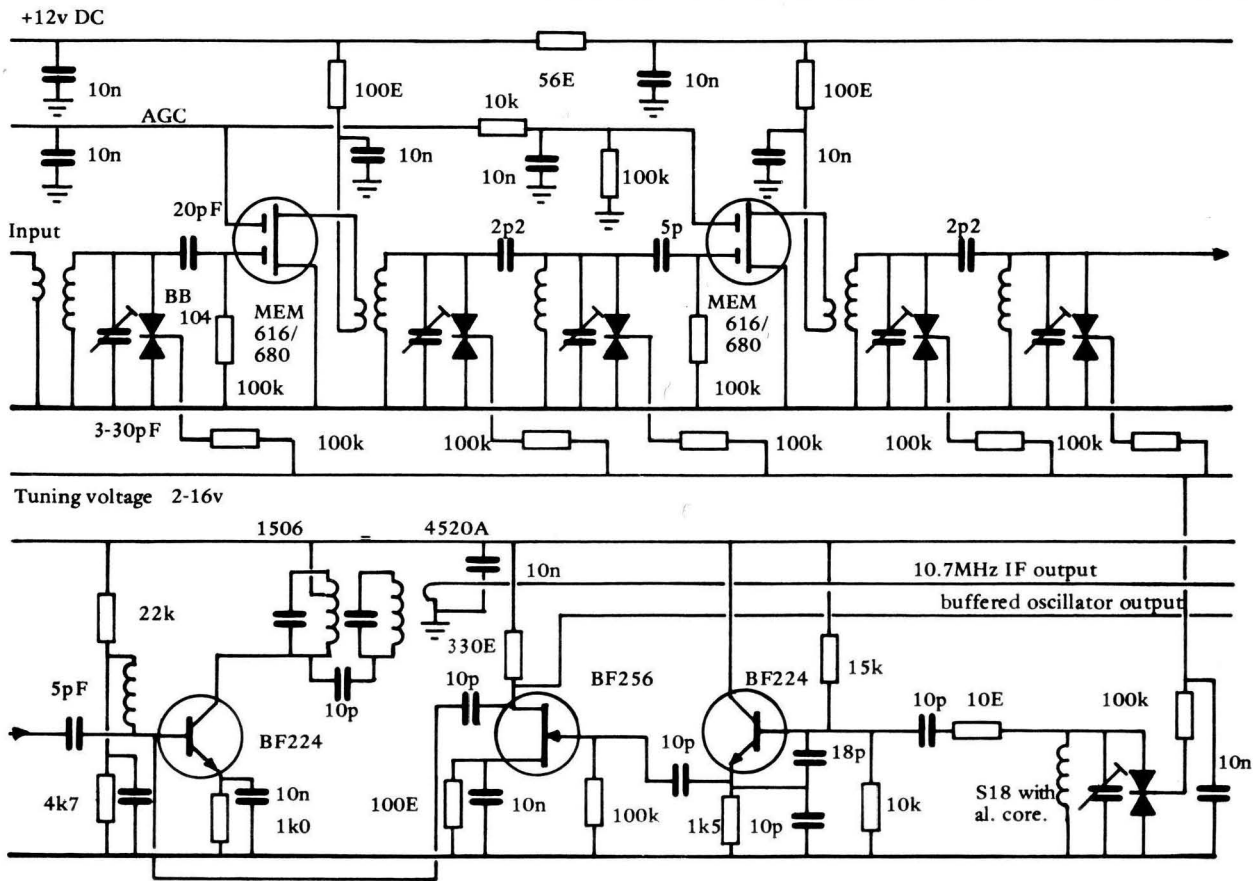

For optimum noise and gain performance, the source of the two input MOSFETs is taken to the nearest available earth point. Greater AGC range may be obtained by using a decoupled source resistor of approx. 100 ohms, but in most applications the gain is the important factor.

All coils are TOKO S18 3 1/2 turn, and coupling turns are now 1 turn only. The bias choke in the mixer circuit is 12 turns of 28 SWG, 2mm internal diameter. All trimmers are Dau green 7.5mm types.

As well as providing oscillator output facilities, the terminal provided may be used for oscillator input, with the internal oscillator disabled, where externally synthesized VCOs are employed.

Electrical diagram of EF5801 VHF tunerhead

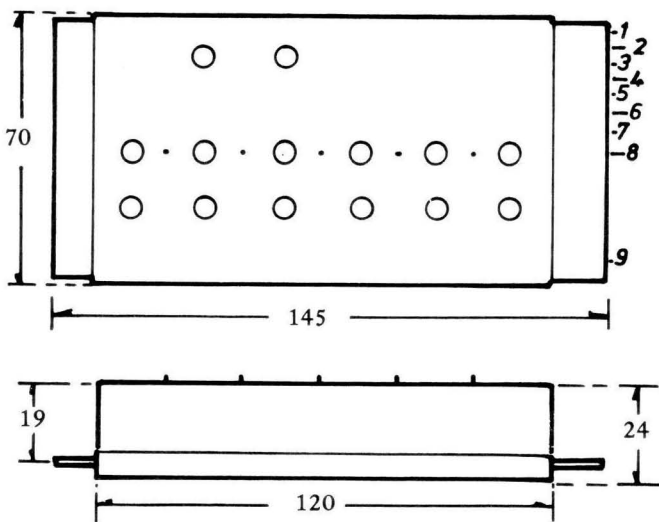

- 1. IF output
- 2. output earth
- 3. +ve supply
- 4. earth
- 5. earth
- 6. AGC
- 7. input earth
- 8. RF input
- 9. tuning bias

The EF5801

The EF5801 employs 2 low noise MOSFET agc controlled RF stages, with SRF tuned circuits to provide exceptional selectivity. The AGC voltages are compatible with 3089/3189 IF systems. The oscillator is buffered via a JFET, and the output taken to a pin at the rear of the unit.

Specification

Frequency range	(standard)	88-108	MHz
Tuning bias		2.4 - 16	v
Supply voltage		+12v	
Supply current	(Vagc=5v)	25-35	mA
Input impedance	(Standard)	75	ohms
Output impedance	(Standard)	300	ohms
Power gain		40	dB
Noise figure		5.5	dB
Image rejection	(fo + 10.7)	>90	dB
IF rejection		>90	dB
Tracking	(88-104)	±2.2	dB
θ	25-55°C	6kHz/°C	
AGC operation	(+5 to 0v)	45	dB
Oscillator	(390 ohm)	100	mV
Oscillator frequency		Fsig + 10.7	MHz

Certain aspects of the performance of the EF5801 series may be customized at extra cost - eg frequency range, impedances and gain. These may involve performance tradeoffs, so please apply for further details, stating your requirements as exactly as possible.

A typical example of performance shows a 30dB S/N ratio with the 7030 IF system, and 0.85uV PD input to the 5801. Careful earthing is essential - use coax input sockets that are isolated from chassis earth, and only earth at the 5801 input.

When using the oscillator output in conjunction with frequency readout units requiring an input greater than 100mV for operation, the following circuit should be added:

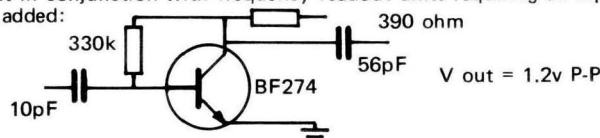

The EF5803 represents the 'state of the art' in VHF band 2 (88-108MHz) FM tunerheads. The two RF stages employ selected low noise dual gate FETs, with very loose interstage coupling to optimize RF bandwidth and selectivity. The mixer a specialized MOSFET- drives into the double tuned 10.7MHz IF output stage, with a separately buffered low impedance oscillator output for counter/synthesiser applications. The tracking of the 6 tuned circuits is assisted by the totally symmetrical physical layout, balancing the strays in each individually screened tuned circuit compartment.

A facility is provided at the tuning voltage input, whereby an external emitter follower stage may be used on the board in cases where noise on a high impedance tuning voltage line may degrade optimum performance, since the lower impedance output of the EF stage will permit the use of large (10 -47uF)decoupling capacitors, without unduly slugging the tuning rate. This facility is provided specifically for synthesizer applications, though may be useful in other circumstances.

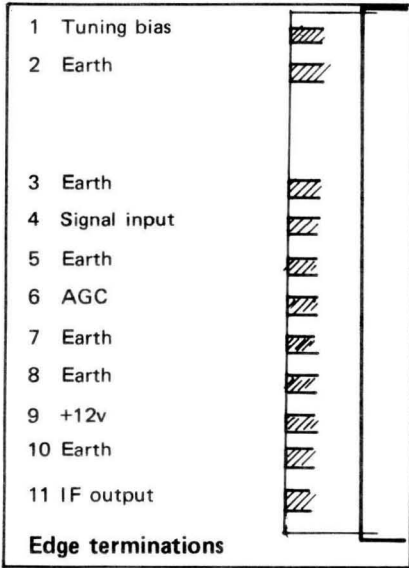
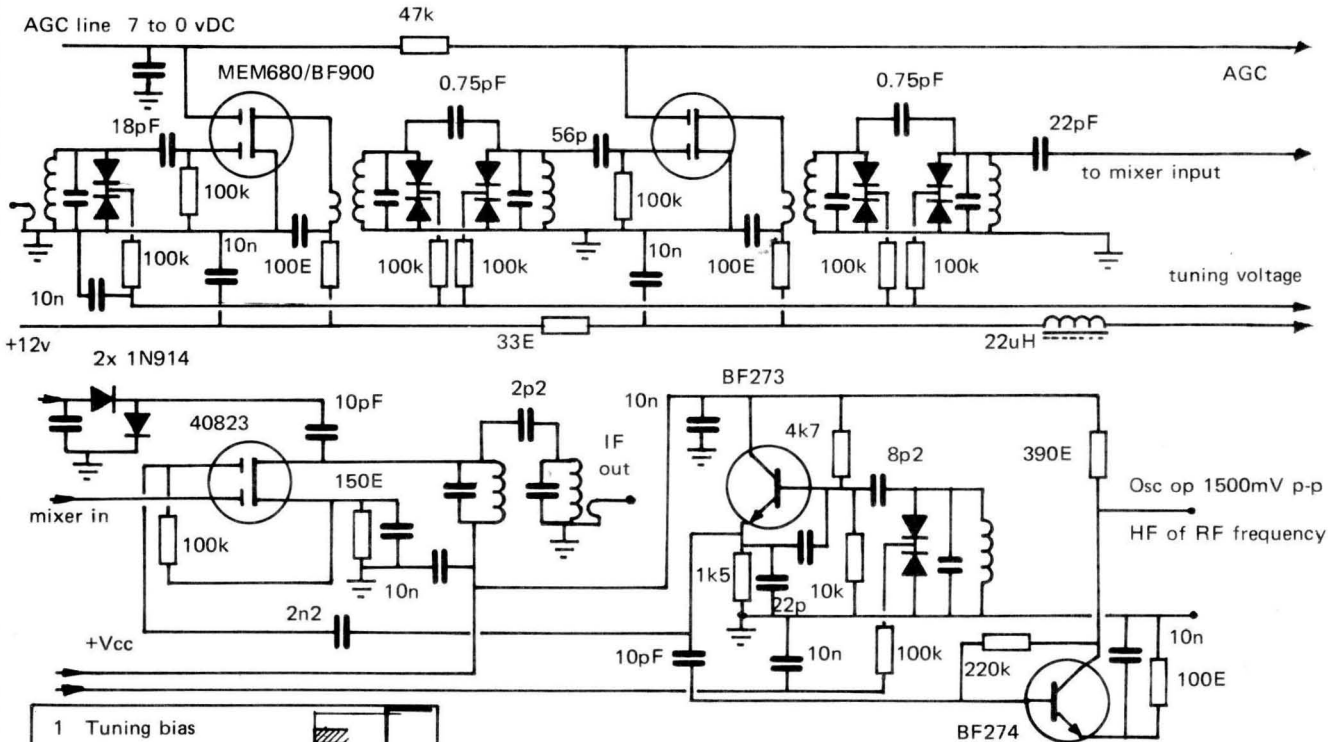

**Electrical specifications**  
 Measurements with Tektronix 7L12 spectrum analyser, Dymar 525B sig source

Frequency range	Bias 2.25v to 9.5v	87.5 to 104 MHz
Supply voltage		12v DC (15v max)
Supply current	12v DC Vcc	32-40mA
Input impedance	standard	75 ohms
Output impedance	standard	300 ohms
Tracking	88-104MHz	±1.5dB
Voltage gain	5.5v on AGC line	44dB
	0v on AGC line	4dB
Image rejection	Measured at 88MHz	> 100dB
IF rejection		> 100dB
RF bandwidth	at -3dB	700kHz
	at -40dB	1.4MHz
Oscillator output	Fsignal + 10.7MHz	1500mV p-p
Noise figure	typical	4dB max

NB the AGC line may be used directly in conjunction with the AGC outputs associated with the CA3089/HA1137/CA3189  
 All tuned circuits employ BB104B type dual varicap diodes  
 See EF5801 for appearance and dimensions. Identification on PCB 'EF5803'

**THE EF5803**

This unit is a derivation of the successful EF5800 series, and is offered in addition to, not in place of, the EF5801. It combines exceptional gain with low noise, and is primarily suited to applications in fringe reception areas, or where DX band 2 listening is required. Signals in excess of 100mV RMS are liable to overload at the mixer stage, and so in strong signal sites, a switchable input attenuator is desirable to enable tuning through local signals, without overloading and 'latching'. In conjunction with the CA3189E IF system (2 6 pole filters used), a useable FM sensitivity of 0.6uV may be achieved.

The correct choice of earthing points, with regard to general chassis or 'ground' points is essential in any system possessing such overall gain. The input socket should not be earthed to chassis, and some experimentation may be necessary to optimize the connection configuration.

The oscillator output is provided at the opposite end of the case to the edge connector, on the same side as the two IF output coils. Below this pad are the spare points for the fitting of the emitter follower components.

Values of input and output impedance, also frequency range are available to special order - at extra cost. The maximum frequency the unit will readily extend to is 180MHz, and the minimum, 50MHz. Please apply for further details if you require such modifications to be carried out. Delivery usually 3-6 weeks.

The unit comes fully prealigned and tested, it will not be necessary to adjust any of the cores - except the final IF transformer to match the subsequent stage. The adjustment of this core should not need to exceed 1 turn - and should not be carried out until a signal has been established as being present in the overall system. Never start adjusting with no apparent signal present, since the likelihood is that an interconnection fault exists elsewhere in the circuit.

We are unable to supply large quantities from stock, and due to the critical alignment, quantity discounts are not available.

General:

The NE 560 series of monolithic PLL ICs includes the high frequency 560, 561 and 562 types - and the low frequency telemetry decoder, the NE565. The NE566 is a simple square and triangle waveform VCO derived from the 565.

The NE560 is primarily intended for applications involving FM, NBFM and signal processing at frequencies up to 15MHz minimum. The VCO output is available in differential form.

The NE561 is identical to the 560 in most respects, except the 561 possesses an analogue multiplier block, which permits the synchronous demodulation of AM signals. The VCO section resembles that of the 560, but for the exception of the differential output facility.

The NE562 is a signal processing device, with individual access to all the main function blocks, for use in synthesiser systems. The parameters are otherwise identical to the 560.

The NE 565 is an entirely different device, which is intended for operation at low frequencies. The working voltage range is greater than the 560/1/2, but the maximum frequency of operation is 500kHz. The major features are the wide bandpass adjustment, and high stability. The 565 is frequently to be found in teleprinter modem applications.

The NE566 is the VCO section of the 565, thus possessing similar electrical characteristics, and making it a suitable choice of device for use in conjunction with the 565 as a clock etc.

Characteristics	560-1-2	565
Min. frequency of operation	Hz 0.1	0.001
Max. .. .. .	MHz 15	0.5
Supply voltage	V 16-26	10-24
Supply current	mA 10	8
Min. input for lock	uV 120	1000
Input resistance	k ohm 2	10
Output with 75kHz dev.*	mV 60	300
*560-1-2 measured at 10.7, 565 with 10% deviation		
VCO temperature coeff.	%/°C .06	.05
Operation temp range	°C 0-70	0-70

General applications include: Tone decoders, FM detectors, data synchronizers, signal generators, modems, tracking filters, SCA detectors, FSK receivers, wide band FM detectors, Ultrasonic decoders, (561 for synchronous AM), (562 for synthesiser applications.)

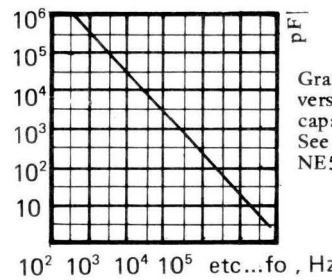

Graph of operating frequency, fo, versus the value of the timing capacitor, Co, for the 560, 1 & 2. See separate formula for the NE565 capacitor values.

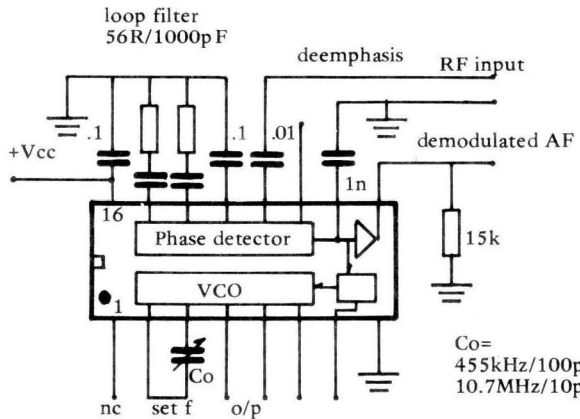

Figure 1. NE560B used as an FM demodulator. PLL ICs make excellent communications demodulators, but inherent noise makes them unsuited to local broadcast conditions, where the HA1137W etc. are superior amplifier and decoders.

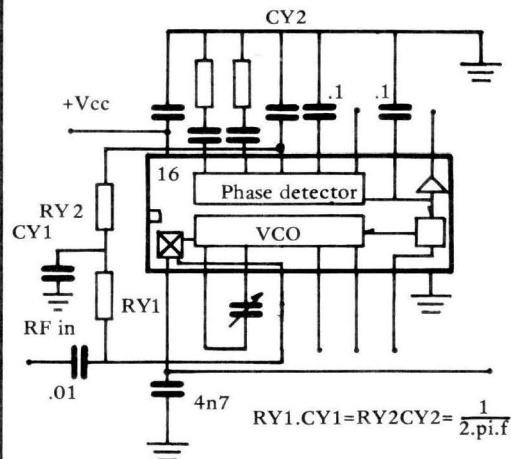

Figure two. The NE561B AM synchronous detector

Figure 3. NE562B used in its synthesis application, in conjunction with an external programmable counter. (8281 etc.)

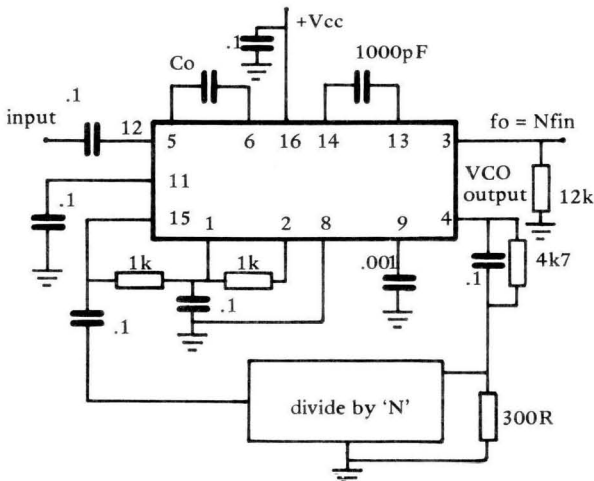
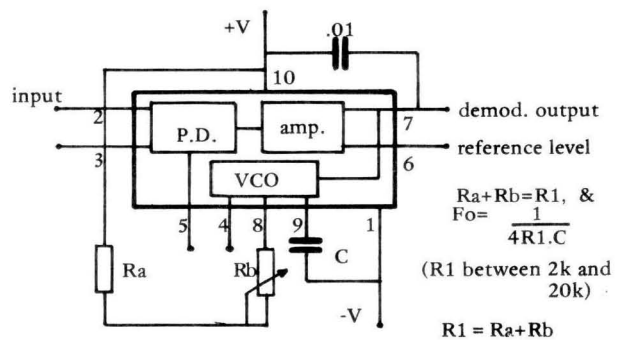

Figure 4. The NE565A as an FM demodulator for FSK, offering increased output over the 560/1/2, but at a lower frequency.



1000pF connected between pins 7 & 8 will eliminate the possibility of VCO instability

The above represent some basic applications of the versatile PLL. Individual devices may have 10 pages of detailed data and applications information, so rather than edit this into a single catalogue page, we will supply up to 5 sides of photocopied information at 7p per side, selected according to particular proposed application(s).

## Larsholt Double MOS FET Field Effect Tunerset MODEL 7252

## TECHNICAL SPECIFICATION

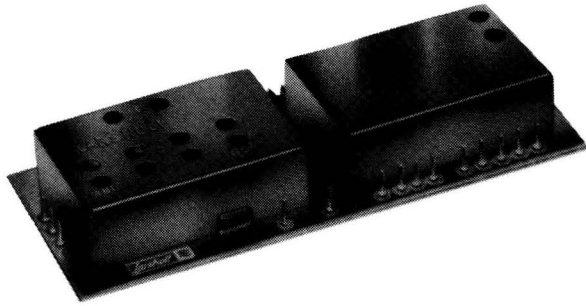

## Physical Size

167.5 mm x 65 mm x 25 mm  
Fixing holes at 150 mm centres.

Frequency range, V tuning + 2.3 -12v dc	87.5-104.5 Mhz
V tuning + 2.3 -18v dc	87.5-108.5 Mhz
Supply voltage (negative earth)	+ 20v dc
Operating current	64mA
Sensitivity, 26 db S/N ratio 75 KHz Mod.	1 uV
Selectivity at $\pm$ 400 KHz	- 55dB
AM suppression, FM mod. 75KHz	
Am mod. 30% Input 1mV	- 55dB
Image rejection	- 56dB
IF rejection	- 80dB
IF bandwidth at - 3db	greater than 210 KHz
IF frequency	10.7 MHz
Antenna input impedance	75 / 300 ohms
Audio output impedance (without preamps)	7.2 k ohms
Audio output level, Input greater than 2uV (without preamps)	330mV
Total harmonic distortion	0.1%
Signal plus noise to noise ratio, 1mV input (deviation 75 KHz f mod 400 Hz)	67dB
AFC pulling range, Input level greater than 10uv	$\pm$ 400 KHz
Frequency pulling $\frac{dVs}{dF}$ (AFC defeated)	$\pm$ 4 KHz / volt
Spurious radiation from antenna	Less than 500uV

The unique FM tunerset, type 7252, combines a high quality tunerhead and IF, to provide an advanced VHF receiver module, with high gain and low distortion. Also included are features such as mute, AFC on all front end tuned circuits, and audio preamplification. The tunerhead employs 4 dual varactor (varicap) tuned circuits, dual gate MOSFET RF and Mixer stages, and a double tuned IF output circuit. Careful attention to screening and layout ensure excellent selectivity and immunity to spurious responses. The IF amplifier and detector stages use a bipolar transistor gain stage, followed by a double ceramic filter, and IC limiting amplifier. The quadrature detector uses a double tuned detector stage, thereby ensuring the lowest possible distortion. Muting and AFC are amplified in two stages of a quad Norton amp IC, leaving two uncommitted sections available for use as audio preamplifiers. The integrating analogue computer technique, controlling the tuning voltage across all four tunerhead circuits, locks the receiver exactly to the desired station. With a 10uV signal, the AFC is operational over a range of 800 kHz. Careful mechanical design, plus attention to screening of both IF and tunerhead, allow the 7252 to be easily located in any receiver design.

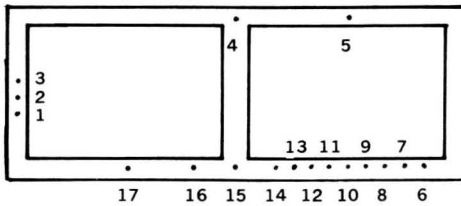

4	+20V stab	Pins 13 & 14, 12 & 11, are available for 2 channel preamplification
5	Signal Strength Meter	
6	AFC (defeat)	
9	AFC out	Connect pin 6 to pin 7 for AFC defeat.
10	Audio out	
15	Muting	
16	Tuning voltage	O- Meter connection between pins 7 and 8, connect together if no meter used.
17	Earth	

## Larsholt Combi FM System Module 7253

## TECHNICAL SPECIFICATION

Dimensions :- 160 x 60 x 26mm Fixing holes 154 x 54mm.

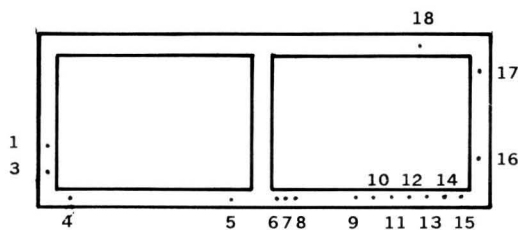

1-3	75 ohm Ant.	11	Muting
5	Tuning volts	12-13	0 - meter
6-7	Stereo Lamp	16-14	AFC off
8	Output left	16-13	AFC on
10	Output right	17	Signal Strength
9	+12 volts stab		

Frequency range	87.5 - 104.5 MHz
Operating voltage (ground neg)	12 V stab
Operating current	55 mA typ
Tuning voltage (ground neg 87.5 - 104.5 MHz)	1.5 - 11 V
Sensitivity (75 KHz mod. 26 db S/N ratio)	1.2 uV typ.
Signal plus noise to noise ratio (1mV, 75 KHz)	67 db typ.
Alternate channel selectivity ( $\pm$ 400 KHz)	55db
AM suppression (FM 75 KHz, AM 30%, 1mV)	55db
Image rejection	60db typ.
IF frequency	10.7 MHz
IF bandwidth	240 KHz typ
IF rejection	85db typ.
Antenna input impedance	75 Ohms
AFC pulling range ( 10uV, 75 Ohms)	$\pm$ 400 KHz
Total harmonic distortion (1mV, 75 KHz)	1%
Audio output impedance	4.7 K ohms
Audio output level (2uV, 75 KHz)	150 mV. RMS
Stereo channel separation (1mV, 75 KHz)	40 db typ.
Stereo lamp (or LED) current	75 mA max.

Frequency range up to 108.5 MHz by increasing the tuning voltage to 15 volts.

This new and technically advanced FM tunerset type 7253, contains an integrated varicap tunerhead, IC IF system, and phase locked loop stereo decoder IC. The tunerhead stage employs 4 dual varicap tuned circuits, N - channel silicon field effect RF transistor input stage with bipolar mixer and oscillator stages. (including thermal compensation). The IF and detector stages are comprised of a bipolar NPN silicon transistor gain stage that precedes a double ceramic IF filter followed by an IC IF system (CA 3089E) with amplification, limiting, detection, muting, AGC, meter drives for both centre zero and relative signal level devices. The AFC from the IC is amplified in a differential transistor pair, and then fed into the main tuning voltage ensuring optimum tracking at all times. The stereo decoder is a monolithic phase locked loop IC (MC 1310P) with manual defeat of the automatic stereo switching if required and a beacon output for either LED or filament lamps.

Further data and circuit diagrams available on request :- supplied with modules.

Monitor PA circuit (x2)

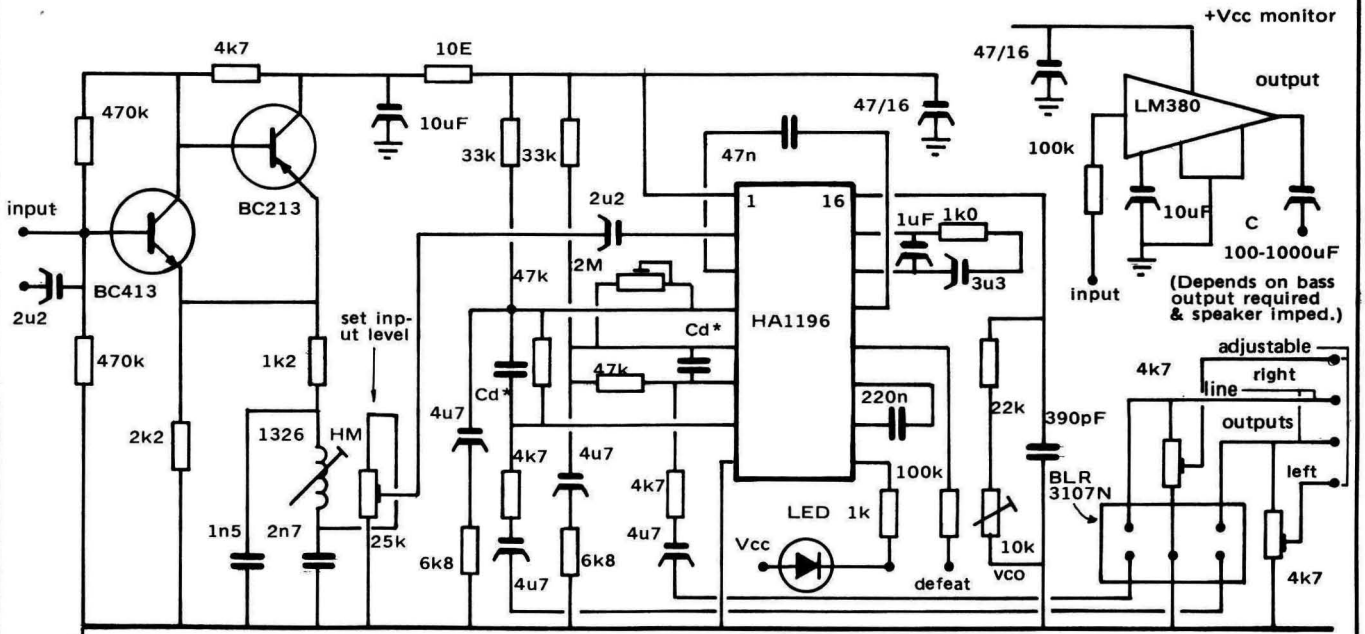

Cd\*:  
These are the de-emphasis components, in conjunction with their 47k resistors. For 50uSec use 1nF For 75uSec use 1n5

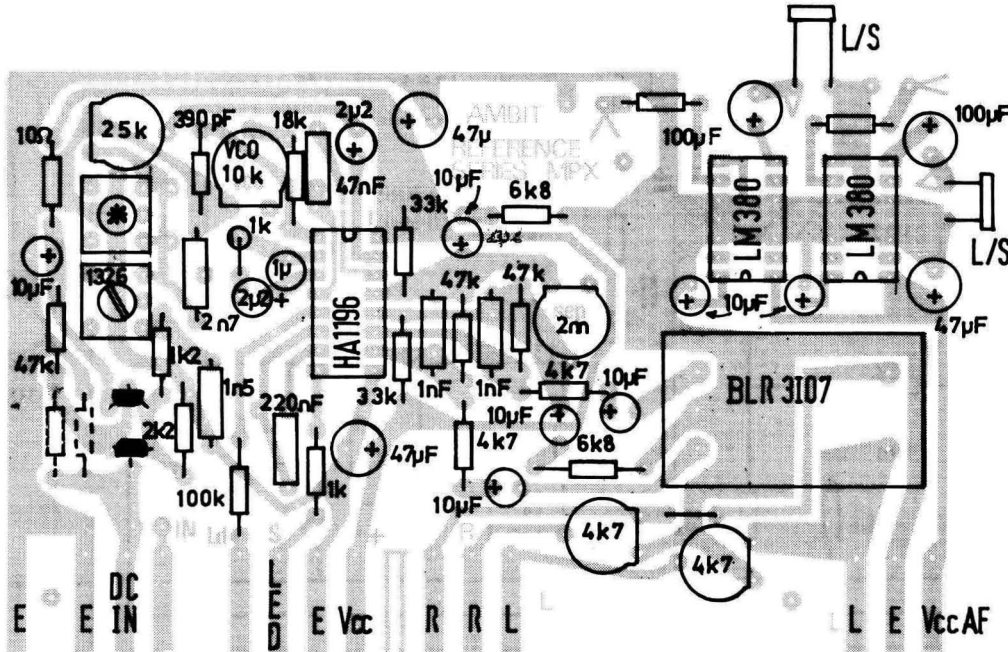

The resistors forming a PD at the base of the input stage are optional - since when this unit is used in conjunction with most IF/detector ICs (3089 etc) the output from the IF may be DC coupled to the base of the input stage, via 4k7.

A separate Power Supply should be used when using the monitor amplifiers, since their class B nature will otherwise cause LF instability in the 91196B. Alternatively, the 91196B supply may be zenered - but remember to connect the LED to the unstabilized supply (max 16v) to prevent mono/stereo switching instability.

The defeat output will force mono operation when it is raised above 0.6v approx. Auto switching is thus possible with the 3089 mute pin voltage output.

Component layout, viewed from underside

available without the LM380's at a lower price

The 91196B is the latest of the decoders from AMBIT. We redesigned the input to allow for a better dynamic range, and thus make user installation adjustments more tolerant of differing voltage levels. The "Birdy filter" stage is an ultra smooth 55kHz low pass filter, with barely 0.5dB ripple from DC to 55kHz. The phase response at this point is crucial if the best stereo separation is to be achieved, and most active filter stages we have examined do not offer the necessary combinations of low phase error and high attenuation of RF frequencies - particularly essential when the IF output from the preceding detector stage is frequently tens of millivolts in amplitude.

The input circuit has also been designed to permit DC coupling to the output of the CA3089/HA1137/CA3189 series of IF ICs, since one of the most annoying aspects of the tuning of an FM system is the loud plop noise that can occur as a signal is traversed. This is often due to the fact that the DC swing at the AF output of the detector is the same as the AFC output - in other words, the DC output describes the detector S curve - and whilst the AF decoupling capacitor may be correctly polarized with respect to the quiescent detector voltage, the extreme of the S curve may forward bias the capacitor, causing additional noise throughout the system. The finite charge/discharge times of the coupling capacitors will also create a nuisance when tuning - and so the DC system offered here will be of great assistance in the refinement of the system. The output of the CA3089 should be coupled via a 4k7 to the base of the input stage.

The VCO is set as with the MC1310 series - a single preset adjustment until lock is indicated by the LED beacon, and then set to centre of the travel of the preset over which the LED remains lit.

**Specifications**

Input for 1v output	Composite	200mV	(RMS values)	LPF distortion	THD	< 0.04%
Signal/noise ratio	Unweighted	78dB		Turnover F		58kHz
Separation at 1kHz	L/R	50dB		Attenuation	200kHz	-22dB
	R/L	48dB		Linearity	DC-55kHz	±0.25dB
Pilot tone leakage	19kHz	<58dB		For additional information, please refer to the HA1196 IC data sheet		
	38kHz	<70dB				

# 7020 FM IF

with Muting, AFC in main tuning bias, meter drives, 0.3% typ thd, 14uV input.

## 7020 FM IF amplifier:

The 7020 uses the CA3089E type of IC as the main amplification, limiting and function stage. It is preceded by two stages of 10.7MHz amplification, each supplied with a two pole ceramic filter - type TOKO CFS/CFSA or Murata SFE.

The AFC function is designed to operate in conjunction with the main tuning voltage, as opposed to the inferior method of applying it simply to the oscillator tuned circuit.

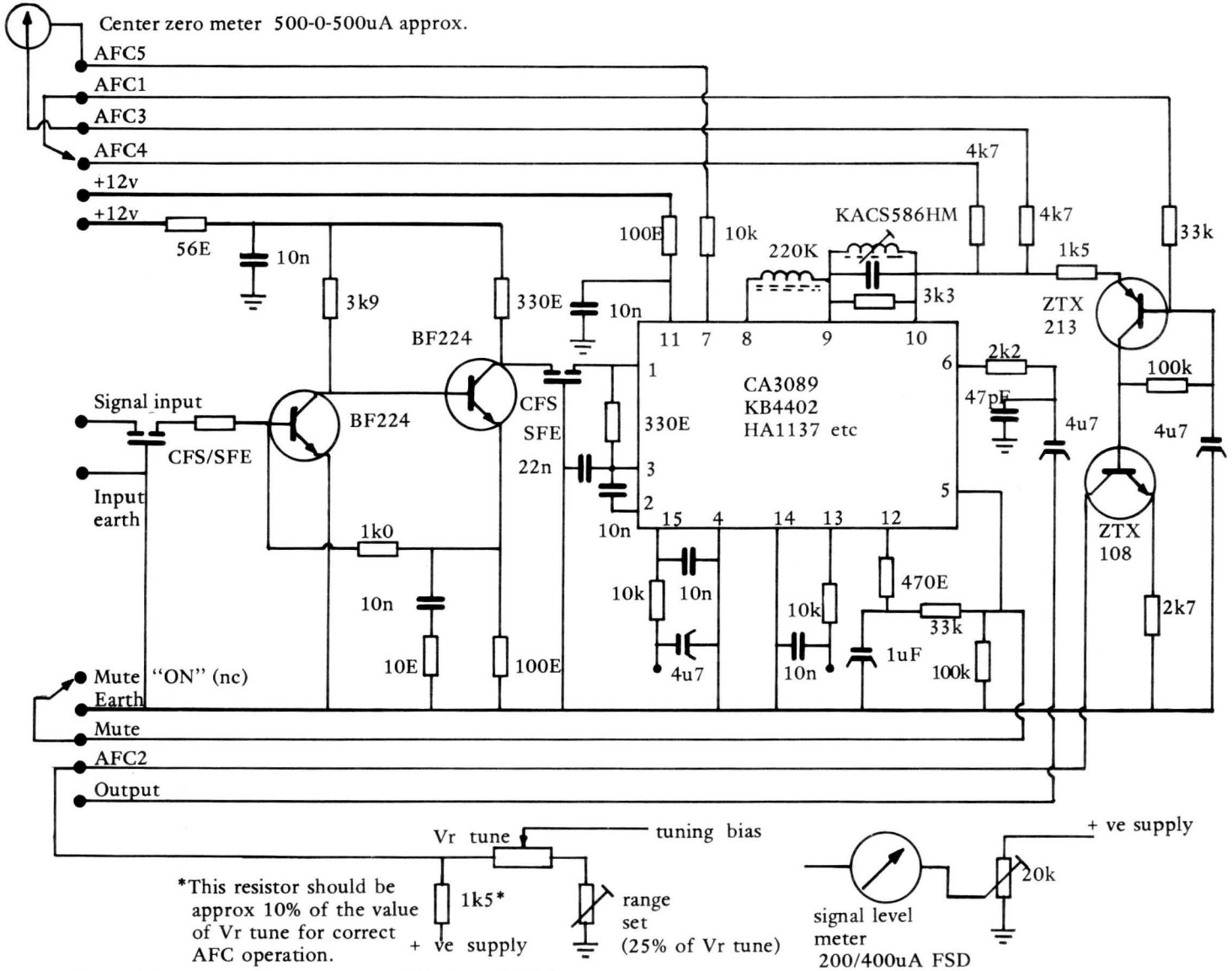
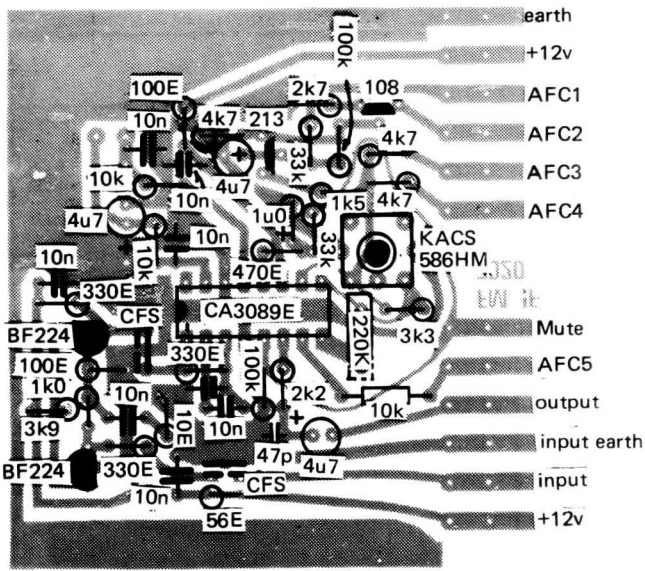

\*This resistor should be approx 10% of the value of Vr tune for correct AFC operation.

For AFC operation, connect AFC1 to AFC3.  
To defeat AFC .. .. . AFC4.

### Circuit and connection details for the AMBIT 7020 FM IF amplifier and decoder with mute, AFC etc.

#### Specifications:

Supply	.. .. .	12v at 25mA
Frequency	.. .. .	10.7MHz (as filter code)
Sensitivity	.. .. .	14uV for 30dB S/N
Selectivity	.. .. .	-3dB : 210kHz
		-60dB : 650kHz

Input impedance	.. .. .	330Ω
Output impedance	.. .. .	>10kΩ
AFC range (100uV in)	.. .. .	±400kHz
All components 16v or greater, resistors ¼ W 5%		

#### Mechanical:

Dimensions	.. .. .	70 x 73 x 12 mm
Terminations	.. .. .	0.2 inch edge connector/or Varelco Varicon pins.



**The CA3189E IF : A complete application system**

Prompted by the advent of RCA's new FM IF, based on the exceptionally popular CA3089E, here is a comprehensive unit that employs the new device in an optimized configuration.

The CA3189E is not all that much changed from the CA3089E in terms of the overall concept and function - it simply refines some areas of operation that have provided trouble for designers using the original CA3089. The most obvious alteration is the adoption of the Hitachi HA1137W system of deviation muting, which effectively suppresses the objectional 'side responses' that are associated with the detuning of an FM detector:

This deviation mute is set in conjunction with the AFC voltage to provide an additional muting voltage derived from the 'S' curve of the detector, so that the AF output on pin 6 cannot shift its DC level by more than the amount determined by the resistor between pins 7 and 10. Since pin 7 is the AFC current source, this is also derived from the 'S' curve detector, and also contains the AF information appearing at pin 6. Since the deviation of the audio signal may exceed the deviation mute bandwidth, it is thus necessary to decouple pin 7 for AF, and leave the steady state DC level, associated with the tuning of the set only. However, there will be some applications where this feature may usefully be employed in the form of an overdeviation monitor, and so the capacitor on pin 7 may be reduced to an RF value only, say 10nF, and the audio deviation level set to the usual maximum of  $\pm 75\text{kHz}$ . To ensure accurate tuning, and thus accurate deviation monitoring, such systems must employ either synthesized or crystal controlled tunerheads, although an excellent alternative is the type of AFC used in this design, where the AF decoupling for the AFC - though not for the signal at pin 7 - is provided by the capacitor to ground from the base of Tr3.

With the AF decoupling in place, the deviation of the signal is immaterial to the operation of the deviation muting - which then functions according to the DC voltage at pin 7, derived from the current source in conjunction with the resistor from pins 7 to 10. The operational point is approx. 1.25v offset from pin 10, and can be determined by a combination of Ohm's Law, and the graph of the AFC current versus the detuning of the carrier:

So, using a resistor of  $15\text{k}\Omega$ , the operating point is:

$$I = \frac{1.25}{15,000} = 80\mu\text{A approx.}, \text{ which from the graph indicates } \Delta F = 40\text{kHz}.$$

To achieve  $\Delta F = 75\text{kHz}$ , first check the AFC current ( $150\mu\text{A}$ ) and so  $R = \frac{1.25}{150 \times 10^{-6}} = 8\text{k}\Omega$  (nearest pref. value to  $8\text{k}\Omega$ )

Of course, the de-tune function offers much more than simple muting improvement, since it means that with a bandwidth of some  $40\text{kHz}$ , the set has to be tuned quite accurately for the mute to lift, and signal to appear - thus reducing the distortion resulting from incorrectly tuned receivers and also perhaps making the centre zero tuning meter a lot less essential in Hi Fi applications.

The de-tune muting voltage is also a great deal more pronounced than the simple noise mute, which is progressive in action. So the control voltage may now be used for a variety of 'step' functions, like stopping a scanning system at a station, lighting an LED as an 'on tune' indicator (though this ought to be audibly obvious!) Do not forget that the noise mute is only effective when there is no signal - or at least, a very weak one - whereas the deviation mute is only effective on the fringe of a signal; so the two muting functions are mutually complementary in their effects. The analysis of the noise mute function is given in the general data for the CA3189E, and will not be repeated here. But remember that their results are 'Ored' so one may appear to work, whilst the other does not. The usual fault conditions are caused in three ways:

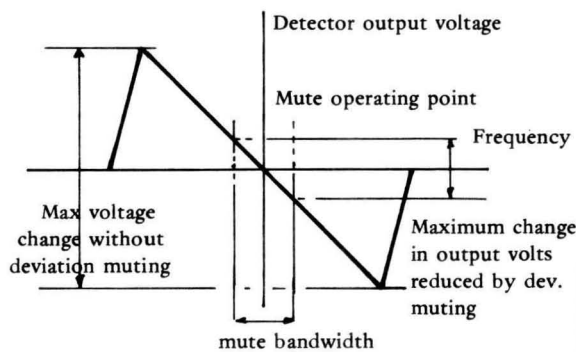

Detector 'S' (or 'Z') curve for a strong signal

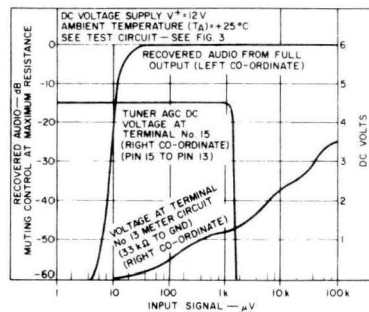

Fig. 5 - Muting action, tuner AGC, and tuning meter output as a function of input signal voltage.

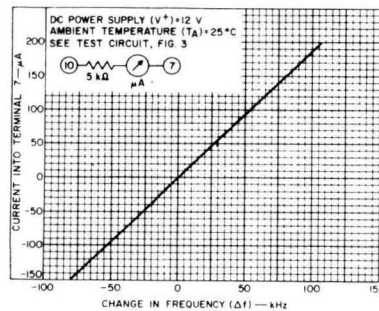

Fig. 6 - AFC characteristics (current at Term. 7 as a function of change in frequency).

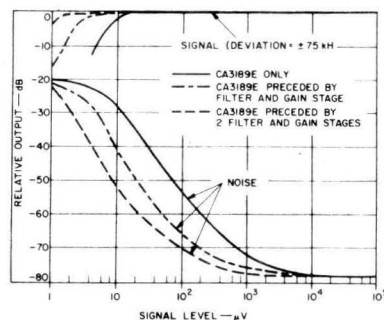

Fig. 8 - Typical limiting and noise characteristics.

Faults in the muting]

- 1) The resistance between pins 7 & 10 is either too large, or the path is simply o/c. This doesn't make any difference in ordinary CA3089 applications, but will stop the HA1137 and 3189 from functioning altogether.
- 2) Too much front end gain, causing the noise voltage to be so heavily limited that the noise mute fails to recognize the absence of carrier. The deviation mute will continue to function however. The cure is to reduce the front-end gain, with a capacitive divider or similar technique; but if that fails, then suspect the layout of some basic instability - a missing decoupling capacitor perhaps. Instability is a layout problem, and may be avoided by following the recommended layouts - and ensuring that signal leads are no longer than necessary at all times.
- 3) The values of the quadrature components, particularly the choke from pins 8 to 9. Too low a value of choke will cause too much IF voltage to appear at pin 9 - and too high a value of the overall Q will create similar difficulties - a fuller discussion of this point is given in the general data section of the catalogue.

In the application described here, pre-3189 gain is provided in two MOSFET stages, with AGC controlled characteristics. The gain is countered to a degree, by the loss of the linear phase filters in the circuit - leaving an overall sensitivity that is compatible with good muting operation, and capable of producing 30dB S+N/N with 0.7uV input to the EF5803 front end. Alternatively, the AGC termination may be taken via 100k to the wiper of a 100k potentiometer across the general supply rail, to provide a manual gain adjustment if required. The threshold of the operation of the AGC output can be set at any meter output voltage from 1.25 to the maximum by the preset provided pin 16. This feature has been included to overcome problems sometimes encountered in very high gain systems, where the noise level was sufficient to cause the AGC to react, well before the optimum S+N/N ratio of the detector had been reached. The preset at pin 15 is used to set the maximum AGC voltage available, but does not control the threshold point of operation.

Time constants on the muting circuit (pins 12 and 5) are chosen to provide a combination of smooth and silent operation. Too slow a reaction would cause fast tuning to catch the noise sidebands of the 'S' curve, before the voltage on pin 5 had time to build - and too fast a reaction would cause 'clicking' and possibly 'chatter' due the snap-action of the circuit. Muting may be defeated in one of two ways:

- 1) Grounding pin 5 of the IC manually
  - 2) Breaking the continuity between pins 5 and 12.
- In this circuit, method 1 is favoured, since the simple grounding operation is more adaptable to touch tune, and other systems where part of the muting function may be controlled automatically within the operation of auto tuning etc.

The AFC in this application is used to drive the main tuning voltage of the FM tunerhead preceding, since this provides a far more satisfactory method than simply controlling the oscillator tuned circuit. Furthermore, by adjustment of the 4k7 resistor from the top of the tuning potentiometer (or bank of pots), the AFC range can be programmed from narrow - to wide tracking, where AFC over several MHz is possible. (Assuming no stronger signal crosses the detector).

The AF output is provided with an IF trap to remove unwanted IF signal from possibly re-entering the input and thus leading to instability. The output may be DC coupled to following stages, especially in view of the deviation mute system, where the maximum DC voltage swing is restricted in range. No de-emphasis is provided at this point.

Finally, the third IF filter is provided for use in particularly crowded conditions, and should only be used when necessary, since the IF bandwidth shrinkage begins to encroach on that required for optimum multiplex transmission. With the HA1196, it is possible to adjust the separation to compensate for quite sizeable phase errors, and thus retain good separation, but tuning becomes more critical at low signal levels. When feeding this filter into the first MOSFET gain stage, the gate resistor to ground should be reduced to approx. 1kΩ, for the purposes of impedance matching.

**Ambit and the CA3189E:**

In common with all other products we offer from our general and consumer ranges, AMBIT has a broad experience of the CA3189E in a variety of application environments. We are thus able to offer a comprehensive design and evaluation facility that is unique amongst distributors of any similar products in the UK.

Bearing in mind our long association with the HA1137W, and before that the CA3089E, we have more practical experience of this type of IC than just about anyone. For detailed applications work, we refer customers to the notes concerning the basis on which such work is undertaken. (Note 8 on the general terms and conditions page)

We offer the device for OEM purchase, and carry substantial stocks at all times, thus where an order is destined to follow our design services, we will normally absorb the costs of such development - we regret we cannot undertake any practical development work on behalf of private customers, except of course, to provide data and theoretical comment in connection with our usual enquiry facilities.

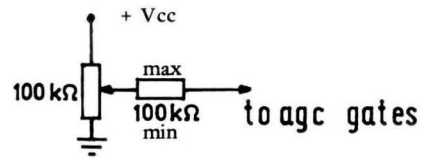

Manual IF AGC control

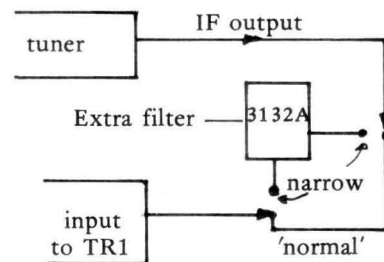
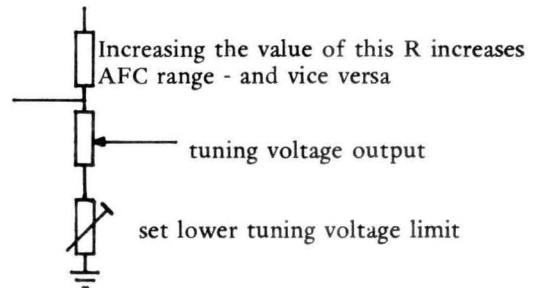
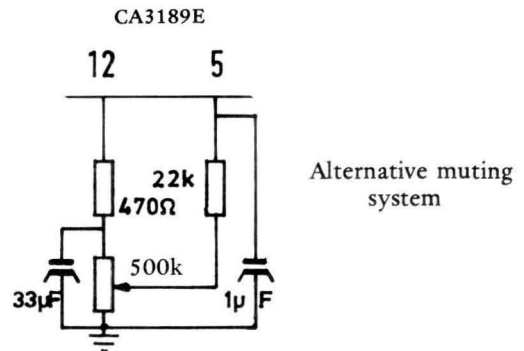

## Technical Specification

<b>Frequency range</b>	87,5-104,5 MHz
<b>Sensitivity</b> { mono	1 $\mu$ V
{ stereo	15 $\mu$ V
<b>Signal plus noise to noise ratio</b> (1 mV, 75 KHz, 400 Hz)	67 dB
<b>Stereo channel separation</b> (1 mV, 400 Hz)	40 dB typ.
<b>Alternate channel selectivity</b> ( $\pm$ 400 KHz)	55 dB
<b>AM suppression</b> (FM - 75 KHz, AM - 30%, 1 mV)	55 dB
<b>Total harmonic distortion</b> (1 mV, 75 KHz, 400 Hz)	0,1% typ.
<b>AFC pulling range</b> ( $>$ 10 $\mu$ V, 75 Ohm)	$\pm$ 400 KHz
<b>Antenna input impedance</b>	75/300 Ohm
<b>Audio output loading impedance</b> (allowed both channels)	$>$ 15 k Ohm
<b>Audio output impedance without 19/38 KHz filter</b>	3 k Ohm
<b>Audio output impedance with 19/38 KHz filter</b> (somewhat frequency dependent)	appr. 3 k Ohm
<b>Audio output level</b> ( $>$ 2 $\mu$ V, 75 KHz) unloaded	1600 mV
<b>SCA rejection</b>	55 dB
<b>IF rejection</b>	80 dB
<b>IF bandwidth</b> (3 dB)	$>$ 210 KHz
<b>IF frequency</b>	10,7 MHz
<b>Radiation</b> (antenna terminal voltage, 75 Ohm)	$<$ 500 $\mu$ V
<b>Power requirements</b> (220 V or 240 V $\pm$ 10%, 48 - 62 Hz)	6 Watt

**BUILD YOURSELF  
A STEREO TUNER**

- that is completely up to date with all features which the electronics of 1978 makes possible.

The Larsholt module system designed for the "do it yourself enthusiast", with only a screwdriver and a soldering iron.

The complete Signalmaster Mark-8 consists of 5 modules, of which the tuner module and stereodecoder are assembled and adjusted at the factory. The remainder are kits. Assembling the kits requires only mechanical mounting and soldering work on the pretinned print-boards, which are clearly marked with each component position. The comprehensive assembly instructions will assist you with every detail.

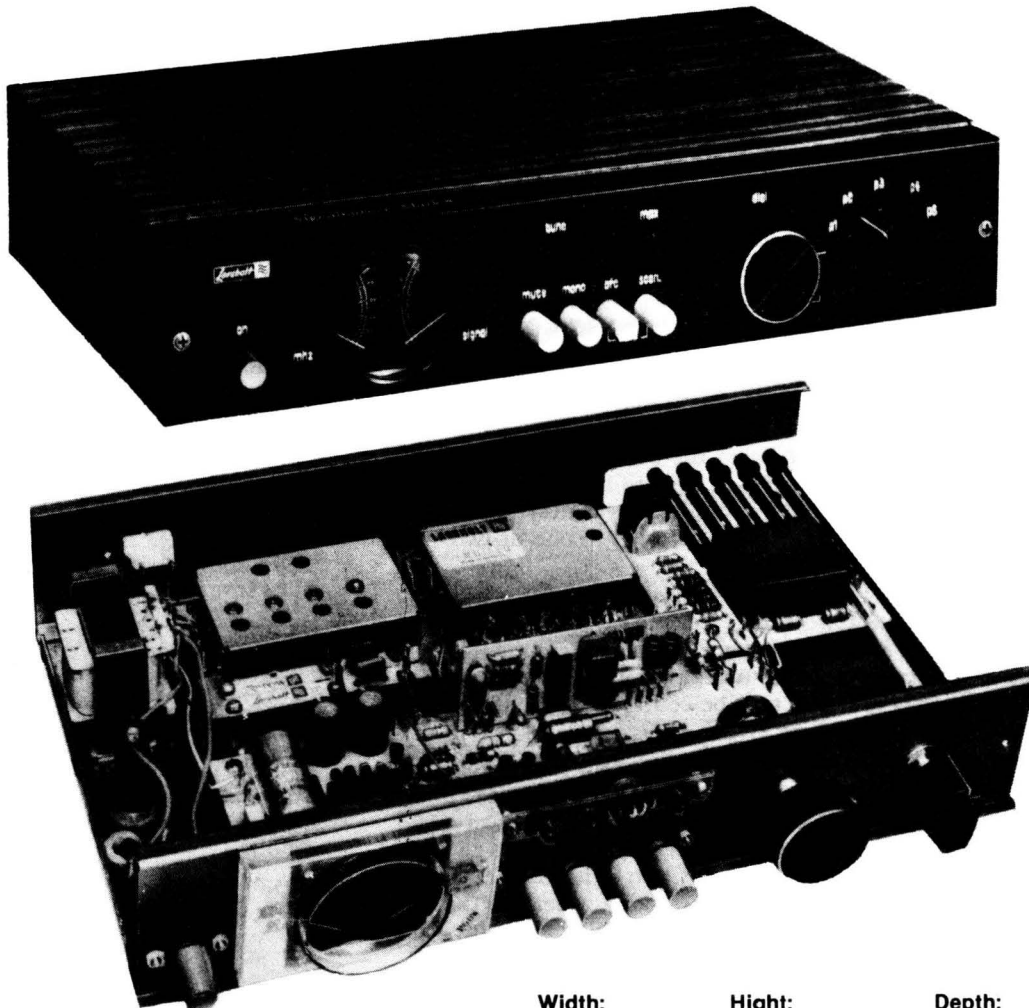

**Width:**  
333 m/m

**Height:**  
65 m/m  
(+ feet 6 m/m)

**Depth:**  
193 m/m  
(+ knobs)

The eighth generation of the Signalmaster series is a tuner which has grown out of many years of experience, in fact since the 1920's. The Signalmaster Mark 8 is built up around the Larsholt Euro-tuner module 7252 which is delivered assembled and adjusted. This module, which Larsholt supply to well known professional producers of Hi-Fi receivers, has obtained an Inter-european appreciation not alone for the high sensitivity, but because it is especially effective for reception in the North West European areas, where the radio channels are congested with powerfull transmitters.

\* The Signalmaster Mark 8 can be programmed for 5 stations besides manual tuning.

\* Analogue computer controlled (automatically searching across the FM band, with a short stay on all but the very weak stations). You can stop the scanning on any selected program.

\* Muting is incorporated to mask noise between the stations. \* Mono switch - to suppress noisy stereo transmissions.

\* Frequency meter and signal strength meter, also balanced LED's for correct tuning indication.

\* Automatic gain control and I/C controlled AFC, which can be disabled. \* Pilot tone filter - removes 19 & 38KHz,

# AUDIOMASTER-II

## The Audiomaster Mk II from Larsholt

Once again, Larsholt have produced a really exceptional audio kit for the home constructor. The pictures display the superb care in design and construction, making the audiomaster a product for beginner and 'old hand' alike. The Audiomaster is compact stylish and powerful - but most of all the wide dynamic range makes this kit a delight to hear under all types of music.

Construction is simplified and assisted by 'on-board' sockets, potentiometers, and switch. The hum from the torroid is so low, that with volume and bass fully advanced, hum is almost imperceptible. (Input loaded/no signal)

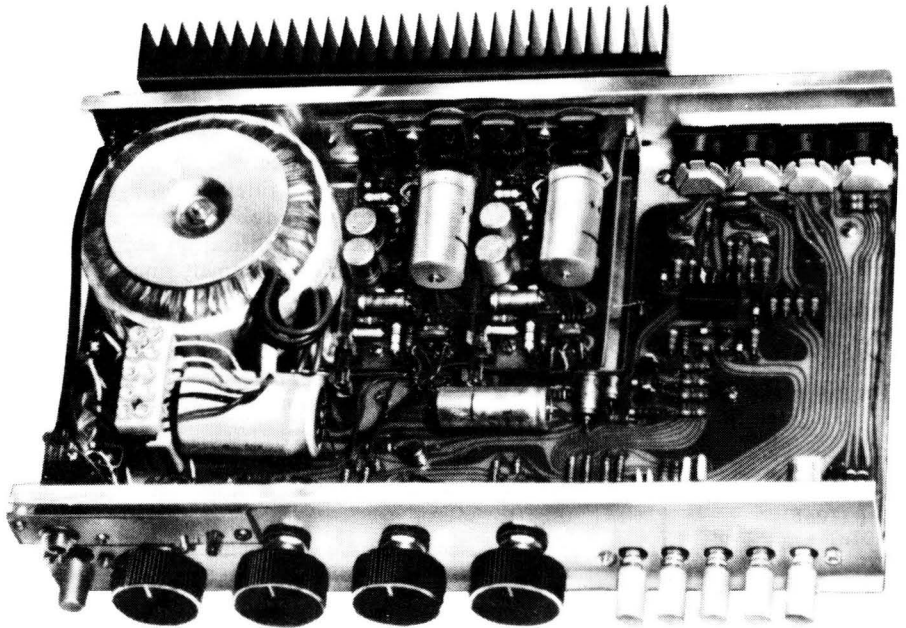

<b>Output per channel</b>	25 W/4 Ω
<b>Signal to noise ratio</b>	80 dB (Inputs loaded)
<b>Total Harmonic Distortion</b>	
At 1 KHz - 25 W output	< 0,5 %
At 1 KHz - 4 W output	< 0,1 %
<b>Input sensitivity</b>	
Tuner, AUX. for 25 W output	100 mV
Tape input	200 mV
Magnetic P.U.	5 mV
<b>Tone control</b>	
Bass at 100 Hz	± 12 dB
Treble at 5 KHz	± 15 dB
Loudness	+ 4 dB at 400 Hz + 6 dB at 20 KHz Flat at 1 KHz
<b>Intermodulation products</b>	
8 KHz/6 KHz	- 70 dB
8 KHz/250 Hz	- 60 dB
<b>Power bandwidth</b>	
40 Hz to 20 KHz	± 1 dB
40 Hz to 100 KHz	± 3 dB

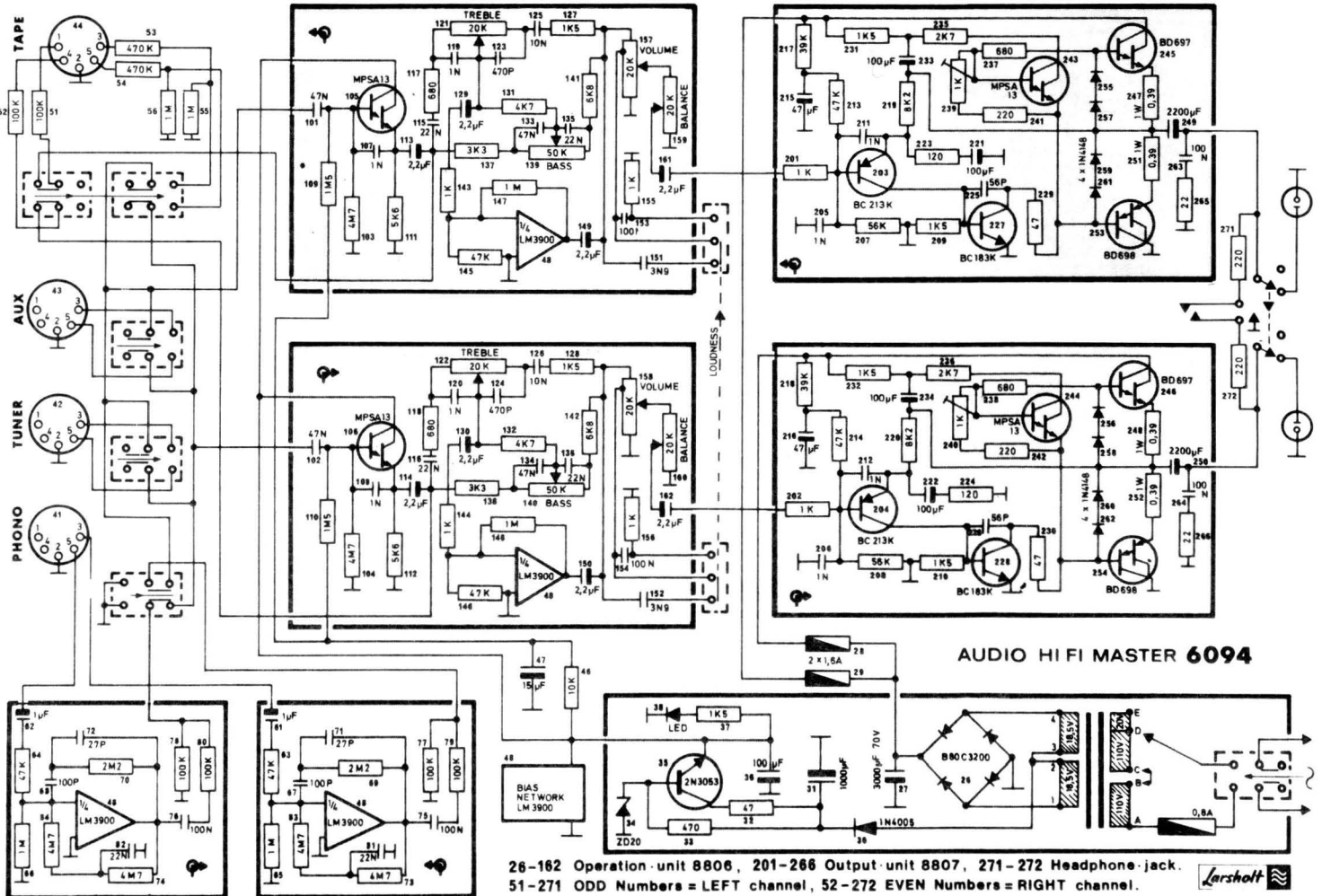

71197

The only MW/LW varicap tuner available

features:

- \* Wide AGC range
- \* Low THD
- \* Ceramic IF filter
- \* Channel heterodyne notch
- \* Signal level meter output

The series 3 Ambit varicap AM tuner is available either ready built, or as a DIY module. Physically, it is similar in size to the Larsholt 7252 tuner set module, and is primarily intended to provide a high quality complement to existing varicap FM tuners.

Specification: (All mod. levels 30%)

Coverage:	
MW	530 - 1600kHz
LW	175 - 250kHz
AGC figure of merit	80dB
Audio output	1v RMS
S/N ratio at 74dBu input	53dB
THD at 100dBu input	0.4%
Tuning meter current	240uA

# An improved varicap MW/LW tuner set

# 71197

The 71197 incorporates varicap tuning with the excellent Hitachi AM radio IC. The standard product is intended to be used in conjunction with the illustrated ferrite rod antenna, though a MW only version may be made using an input RF transformer, type RWO6A6408, and a short length of wire for an antenna.

An FET source follower input stage is used to allow the minimum of wiring and switching complexity at the ferrite rod - and the actual input RF level is pre-settable by means of the preset pot in the source.

The IF is filtered through a ceramic IF filter stage following the mixer, and after further amplification at IF, the signal is fed to an extremely linear detector stage. At this point, the references for the AGC and meter driver circuits are also obtained for further processing within the IC. The AGC is programmed externally through the network between pins 14 and 12.

In the 71197, a series tuned notch for 9kHz audio whistling is included, using a 36mH in series with a .01 capacitor. The notch may be lowered to approx 4.5kHz by simply increasing the value of the capacitor to .02uF.

The audio stage itself is designed with a great deal of negative feedback, to work into a low impedance load. (Line level) Tuning is accomplished by using a 27v positive supply, fed to point 'A' on the board. The coverage is given in the specification summary, but individual samples may vary slightly at scale extremities. Switching between MW and LW is easily accomplished by applying the positive 'SW' voltage to point 'B' for MW, and to point 'C' for LW.

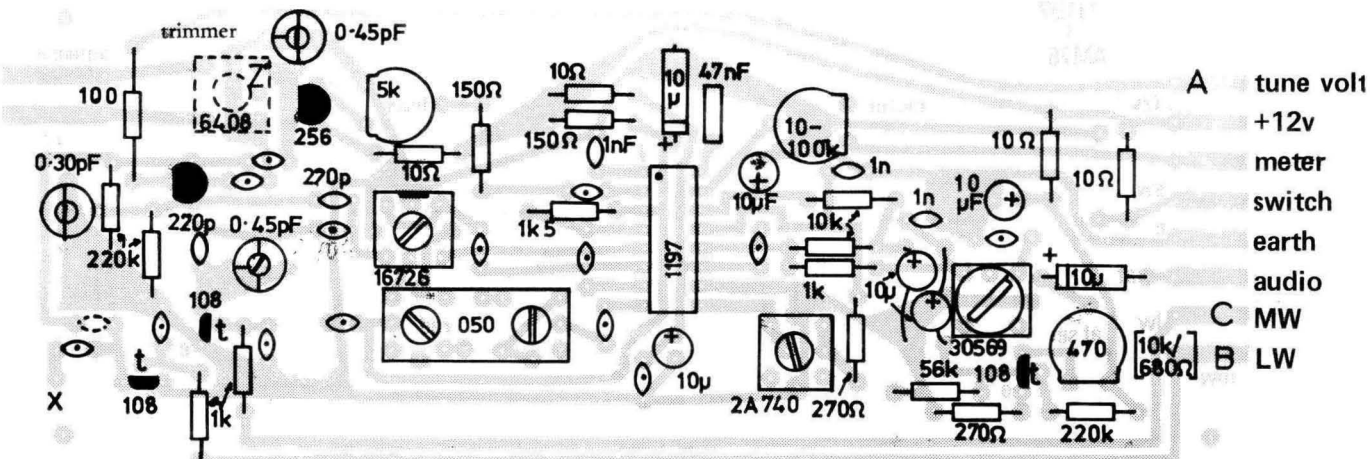
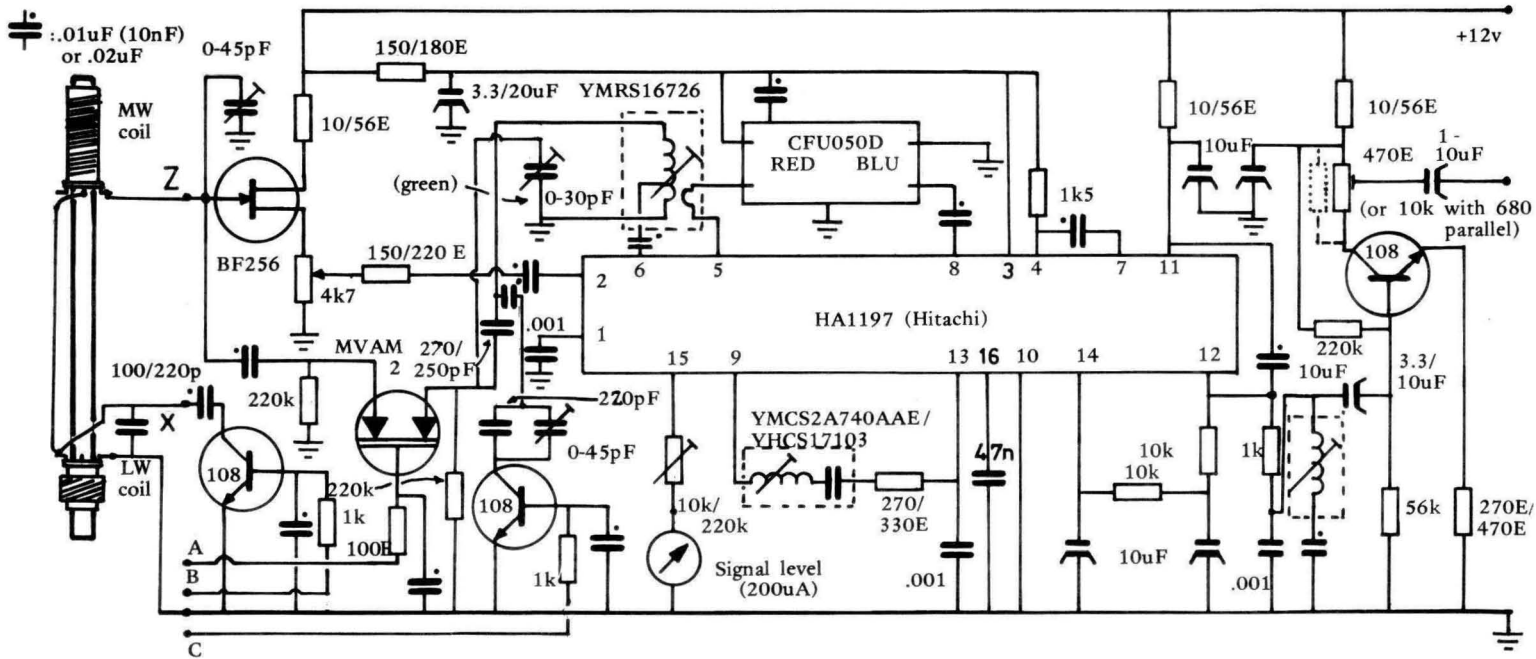

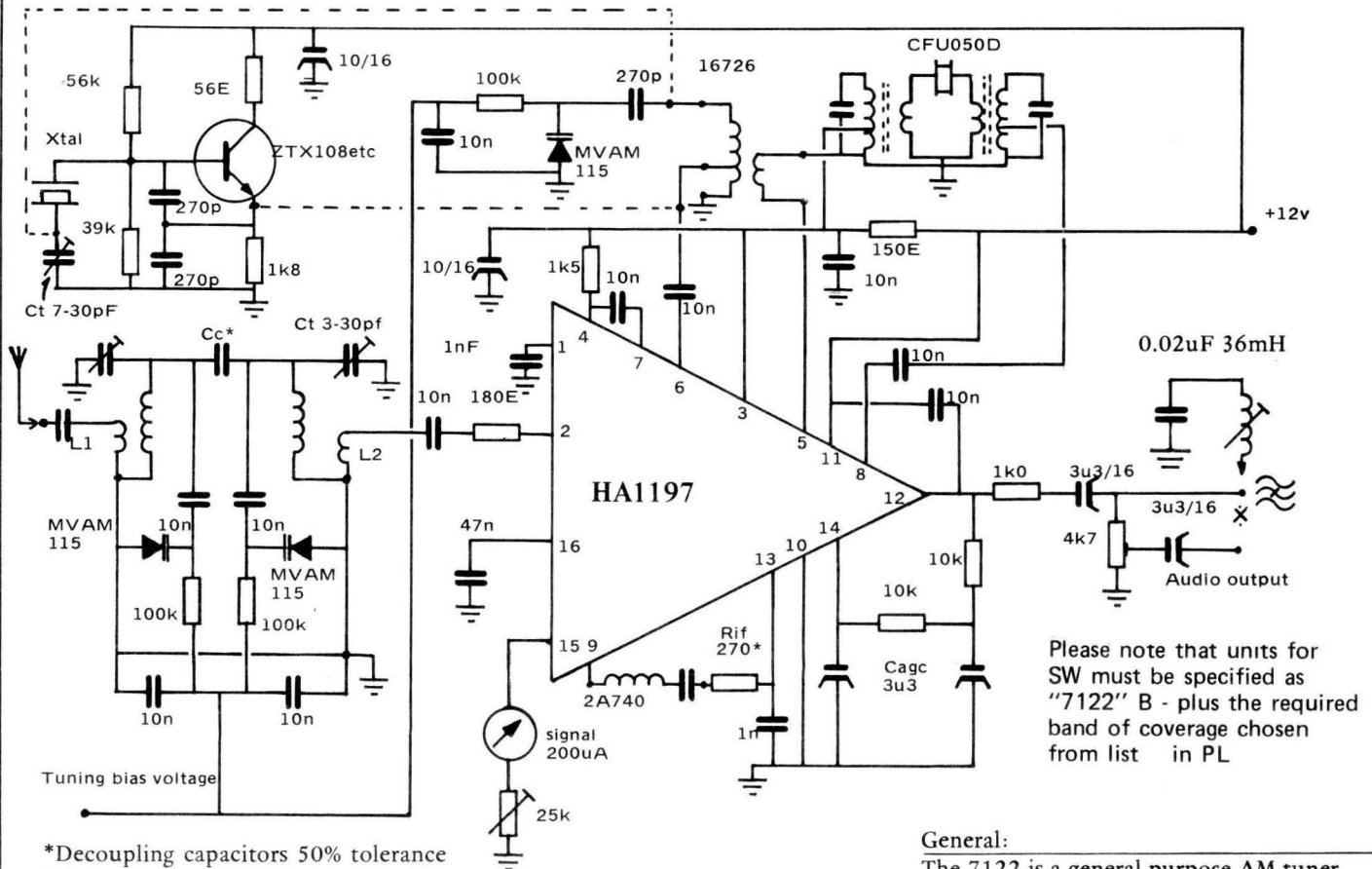

Please note that units for SW must be specified as "7122" B - plus the required band of coverage chosen from list in PL

\*Decoupling capacitors 50% tolerance  
Other components 10%

**General:**

The 7122 is a general purpose AM tuner unit suitable for three stage varicap tuning or for crystal controlled operation in the range 175kHz-30MHz, with the correct choice of coil pack.

The dotted lines indicate the connections to be made when employing the varicap tune facility. (Omitting the components associated with the crystal control).

The non-adjustable audio output provides a convenient point for a notch filter - which operates at audio to remove the channel whistle frequently interfering with reception on SW bands, without unduly restricting the IF bandwidth.

Stability of the unit is excellent, and the exceptional AGC make the 7122 a superb unit for use in sound distributive equipment. By using lower capacity swing varicap diodes, it is possible to provide a very extensive bandsread for specific bands .

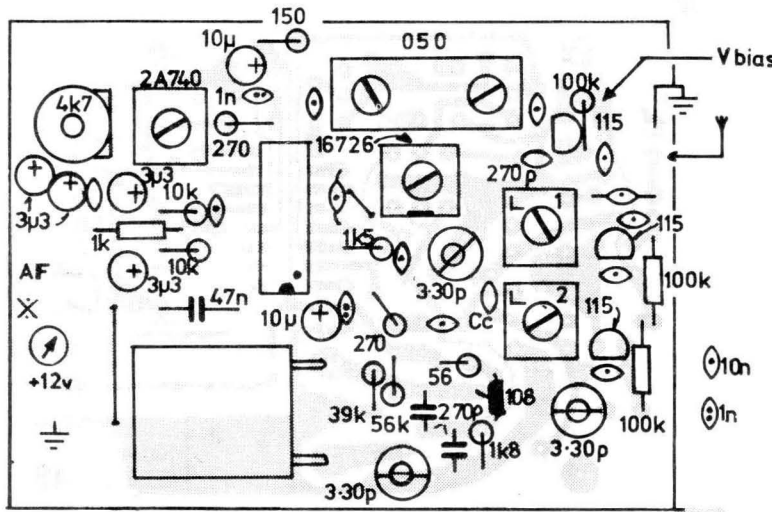

- \*Cc The coupling capacitor for the input stage, values will vary with selected frequency range. Generally 8p2 will be suited to most applications to 7MHz. 7-14MHz use 4p7, above 14MHz 2p2. (Smaller values will increase selectivity at the expense of sensitivity.)
- \*Rif Rif is nominally 270 ohms. It will be possible to increase IF gain by reducing this value, though instability may result at higher frequencies. It must not be used as a panel control for gain, since it is 'live' at IF.
- Cagc The AGC reaction time constant capacitors are nominally 3u3. Smaller values will speed up the reaction time, but too small a value will lead to low frequency distortion, and ultimately, instability.

MVAM115 diodes are tuneable with a 15v bias supply , though with 12v, a substantial coverage is achieved. However, in strong signal applications, and to minimize the effects of tuning voltage drift, the MVAM125 may be employed in a direct replacement manner. The tuning bias range will then be required to extend to 25v.

Coils for the medium wave are:  
Oscillator - YMRS16726ZMS5 (as shown above)  
L1 and L2 - RWR331208 (or RWO6A6408)

Sets for the remaining bands will be advised in due course-meantime it is possible to devise them from the 10K coil assemblies, and the appropriate winding information.

The audio notch filter should be calculated to notch the channelling frequency, usually 8-9kHz, though the values given here are tuneable over most required ranges. (36mH coil, TOKOCLNS30569)

**SPECIFICATION** (also please refer to HA1197 data sheet for further details)  
Input sensitivity (50 ohm) for 26dB S/N (weighted) 4-6uV 1.6MHz , 8-10uV 21MHz. (PD)  
Coils specified above are for M.W. information on coil packs for L.W. S.W.1 S.W.2 and S.W.3 available on request.

# LINEAR PHASE FM IF

- The 7030 FM IF amplifier module features:
- MOSFET input preamp
  - Linear phase 10.7MHz filter (BW -3dB 240kHz)
  - Ultra low distortion double detector (0.08% typ)
  - High AM rejection (45-50dB)
  - Meter output (log law) (displays 1uV input)
  - Delayed AGC (4.5 to 0v)
  - Amplified 'additional' AFC system for varicaps (400kHz)
  - 5uV input sensitivity for 30dB S/N
  - Overall sensitivity with EF5800 typ. 08uV

The 7030 is a unique edge-connected FM IF module designed for optimum performance in stereo tuners. (The edge terminations are compatible with the lower cost 7020 IF module, and thus the two units are directly interchangeable.) The use of screened leads for input and output is essential, and all earth paths must be of low impedance for stable operation. The AFC system provides AFC that is compatible with any existing varicap band two tuner.

The double tuned detector needs to be aligned for minimum distortion, using an audio distortion factor meter - though a close approximation may be made by the amateur constructor. The detector coils will require no more than a single turn to trim.

The AGC should be fed to the gates of the front end RF stage(s) via a 10k resistor.

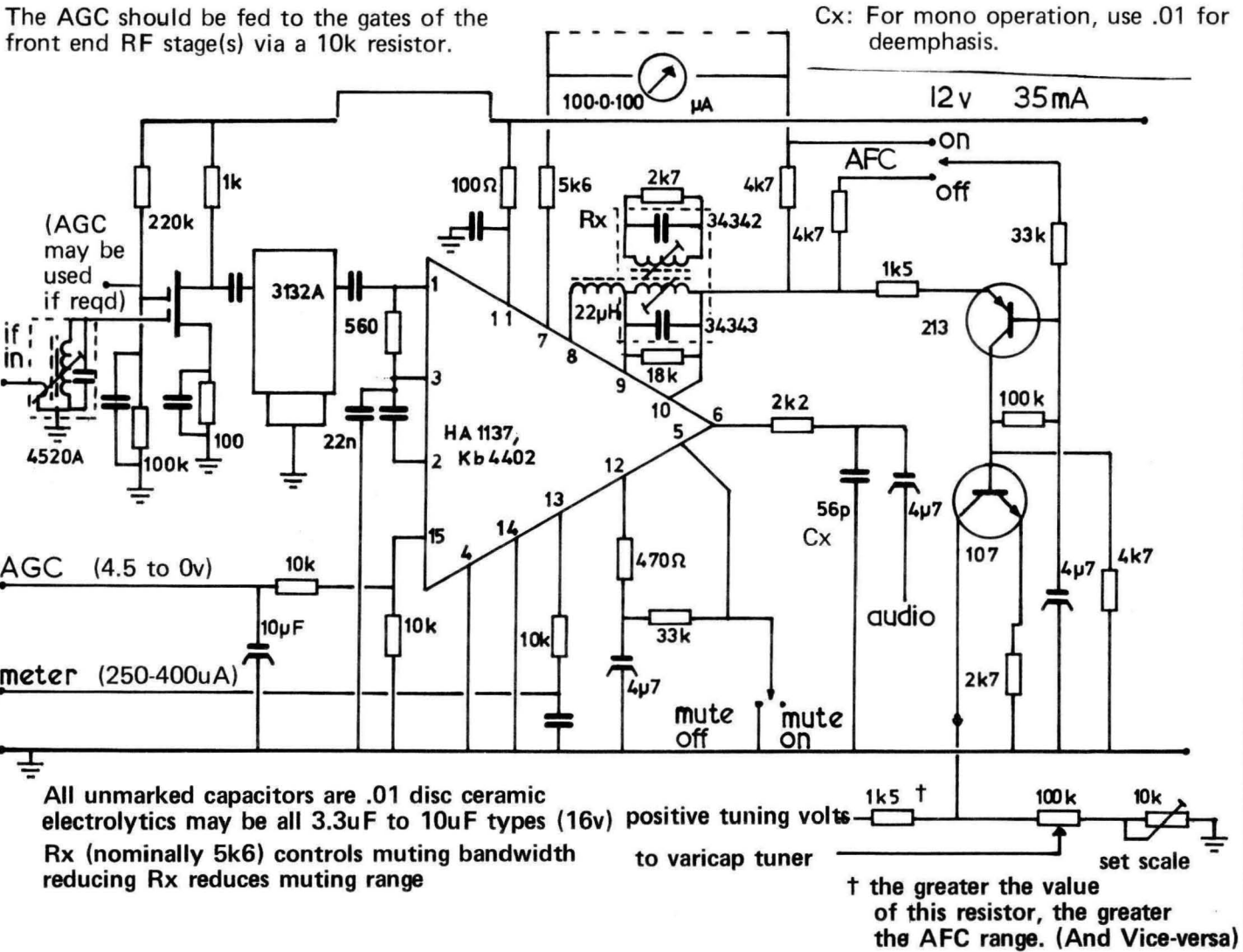
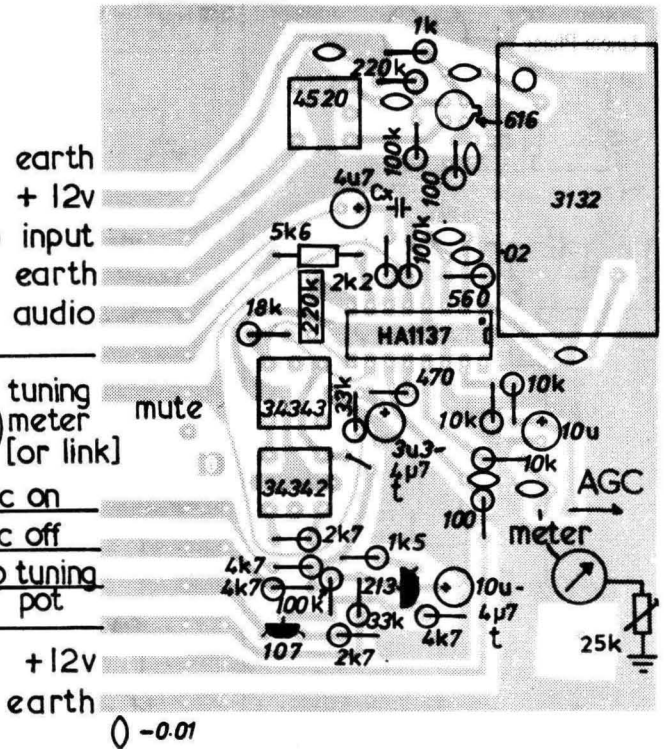

One of the benefits of of integration is that large scale complex functions cost little more than simple transistor arrays - on the micro scale of IC wafer production. The silicon slice has to be big enough to enable the bond wires to be fixed, so as the manufacturers have become more adept at the relatively new art of IC design, there has been a tendency to produce an extremely refined system - since it costs little more than the simple reproduction of the basic discrete arrays/circuits.

The TDA1083 exemplifies this trend throughout its conception. A simple transistor AM mixer would probably have been acceptable to the consumer manufacturers bred on what are really extremely basic radio designs - but the TDA1083 goes off into the realms of communications technology, and ends up with a superb four quadrant multiplier stage - offering exceptional dynamic range, low oscillator leakage and low noise. After all, it's only a couple of microns on the chip.

Likewise, the oscillator stage could be a one transistor effort, with the need for two feedback point on the coil, and all the additional aggravation that leaves the designer when band switching has to be considered. But since the lead of the CA3123E, the AM oscillator has been based around a differential transistor pair, forming something akin to an RF flip-flop but requiring only a single oscillator coupling winding - and in fact, the coupling winding itself is not really essential, but in the interests of purity, it is customary to use it to provide a lower loading on the tank circuit.

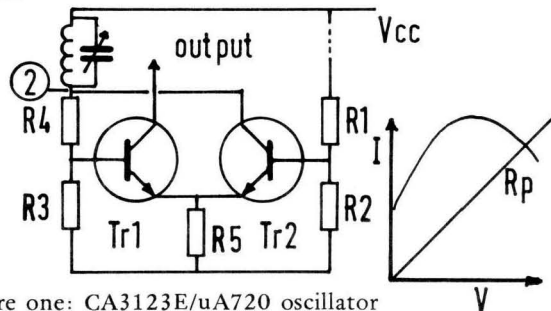

Figure one: CA3123E/uA720 oscillator

In the TDA1083, the oscillator looks like:

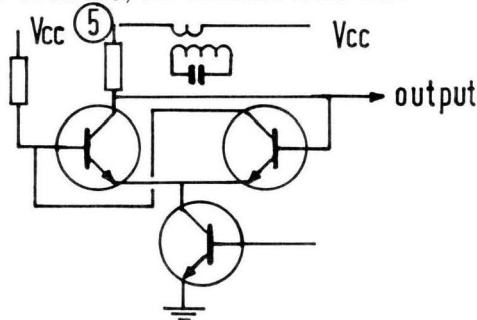

Figure two: TDA1083 oscillator

The bias on Tr2 is derived from the divider r1/r2, and since r4/r3 on Tr1 form the same divider ratio, pin 2 should be taken to the same positive reference for correct operation. Thus pin 2 goes to Vcc via the tuned circuit(or coupling winding thereof). The oscillation frequency is thus determined from a simple parallel tuned tank circuit.

To sustain oscillation, the AC impedance of the tuned circuit must exceed the attenuation of the R3/R4 network and the input impedance of Tr1. The parallel resistance of the tank circuit should lie well within the V/I curve at pin 2.

Which is easily recognizable as a derivation of the CA3123E type of oscillator. In this case, the design has been optimized for operation at low voltages.

The fading out of a portable radio is nearly always due to the oscillator stopping at low voltages - the characteristic "brown outs" when the radio volume rises to a peak, and then as the increased AF output causes the aging battery voltage to drop, the oscillator stops, the battery voltage rises and the whole process repeats itself creating a situation of slow oscillation.

The TDA1083 is almost unique in its operational voltage range, and thus battery life is extended to its very maximum. The FM oscillator, will however probably stop long before the AM section - you cannot have everything !

The IF system is tried and tested in many other ICs - and requires little explanation, except perhaps to point out the use of pin 16 as a gain control for the IF - the AGC voltage may be also be monitored at this point to provide a function for a meter suitable as an indication of signal level. The Detector stage is cleverly arranged so the FM IF transformers from pins 15 and 16 present low impedance to AM IF signals at 455-470kHz, whilst the AM IF transformer effectively decouples the top ends of the FM IFs at 10.7MHz.

In the AM mode, low level detection is provided by differential peak detection - a method that avoids the problems brought about in earlier ICs requiring external peak detection, where the final IF carrier voltage was big enough to find its way back along the board to foul up the IF input stages, and cause the whole IF system to behave in a manner not conducive to high sensitivity and stable operation. (The TBA651 is perhaps the classic example of this syndrome.)

In the FM mode, pin 15 represents a simple IF output point, and the coil on that pin is not directly concerned with the FM demodulation. In fact, the FM demodulator may be likened to that in the CA3089E - although it is a much simpler internal arrangement. The detector quadrature coil is at pin 8 - and instead of a choke feed (as per CA3089 family) a simple capacitor is used to provide phase shift of 90° between the limiter output at pin 15, and quadrature coil at pin 14. In fact, a 22uH choke could be used here - but this would then effectively short circuit the AM detector coil at 455kHz. The detector coil has an "S" shaped frequency/phase characteristic (as does any tuned circuit of this type) and so the phase shift is only 90° at the carrier centre point. (10.7MHz) During the excursion of FM, the phase relationship of this coil will then vary - producing a continuous variation between the zero phase and quadrature signals. The limiter output then is a train of pulses of varying widths, which are subsequently integrated to provide the audio output.

It is worth mentioning here that the capacitor produces a DC drift at the audio output pin that although frequency related, is in the reverse sense to the AFC voltages usually associated with IC detector systems. The problem is not easily solved in a low cost fashion - and will be the subject of further discussion later in this feature.

The quadrature coil is provided with a damping resistor, mainly to provide a linear characteristic over the range of frequency associated with FM transmissions. In mono configurations, the bandwidth can be a great deal narrower than in stereo - and so the recovered audio can be improved by not over damping the coil.

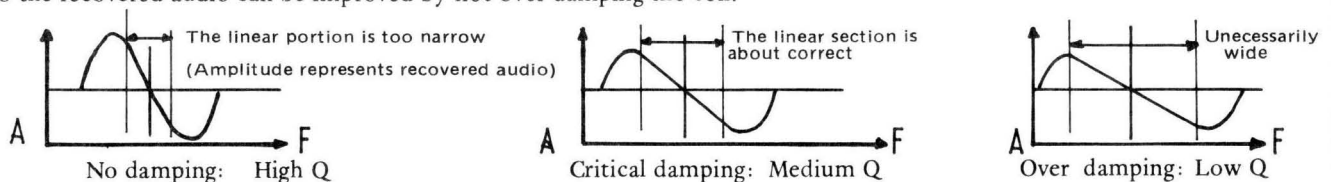
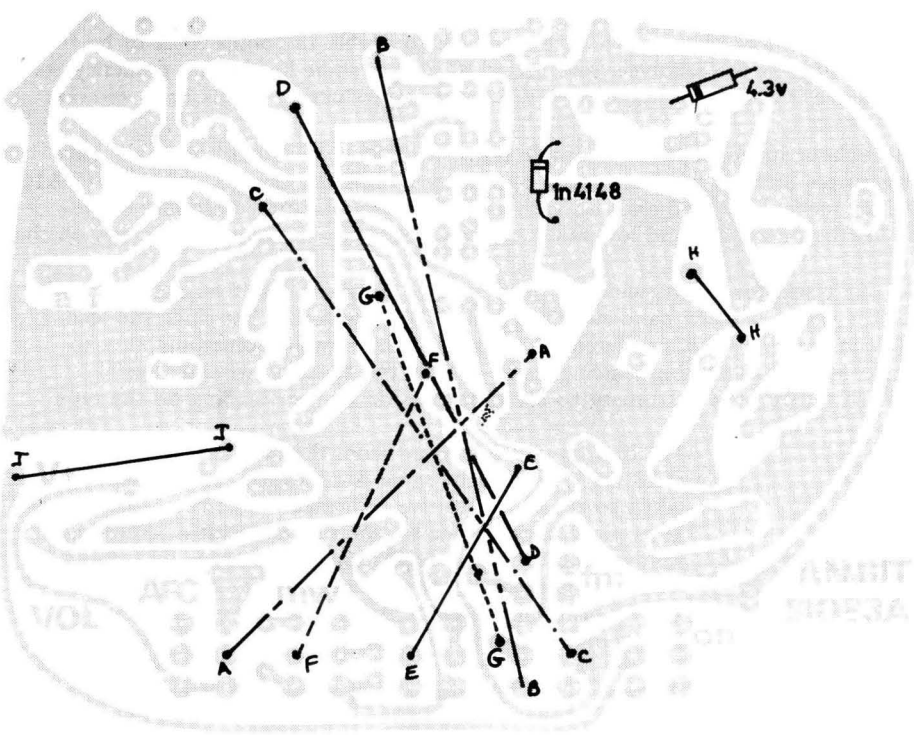

Figure three: Quadrature phase and amplitude characteristics

( $Q = F/\text{Bandwidth}$ )



The TDA1083 is not a particularly layout-sensitive IC, but the main point to bear in mind is the power drawn on audio peaks, and hence the substantial current requirement of the main power earthing pin. The track to this point must be low impedance, or audible LF instability in the form of motorboating will occur. The battery supply should also have a low impedance, and if driving low speaker impedances, an extra 1mF of main Vcc decoupling will be necessary at the positive supply pin.

In the layout shown here, please note the 1k resistor adjacent to the 94AES30456 at the top left, since in some instances, this has been shown as 100E.

The double line on the coil cans indicates the face upon which the identification is printed.

In battery powered applications, it is advisable to clamp the base volts of the FM LO to prevent wide voltage fluctuations from causing VHF/UHF instability at this point. A Zener diode of 4.3v is shown on the reverse side diagram, and its use eliminates the need for other methods - such as ferrite beads on the base - to be used. Below a battery voltage of 4.3v, the zener will obviously not stabilize, but this is not likely to be noticed in operation.

At all times, remember the main supply must not exceed 12v - or the internal shunt regulator may overload, and burn out the IC. In 91083A serial PCBs, the reference end of the AFC varicap is shown as being taken to ground - this must either be taken to +Vcc, or the bias point, pin 10, of the IC. It must be decoupled to RF. It is possible to operate with the LO on the low side of the received carrier with the AFC diode taken to ground as its reference, but this may lead to additional unwanted image reception problems.

Attention is drawn to the fact that certain coils are fitted with pins that are not required, clipped off. Do not attempt to remove coil pins by pulling, or part of the main winding may be destroyed.

L3 deserves special mention, since in conjunction with 470pF, this forms a low impedance IF trap circuit at the input to the self oscillating mixer. It is 3mm diameter, and consists of approx. 15t with no core. 30-36SWG self fluxing. A large error at this point will be likely to cause FM IF blocking due to excessive 10.7MHz IF breakthrough - especially at night. Apparent FM instability problems are frequently rectified by paying attention to this part of the circuit.

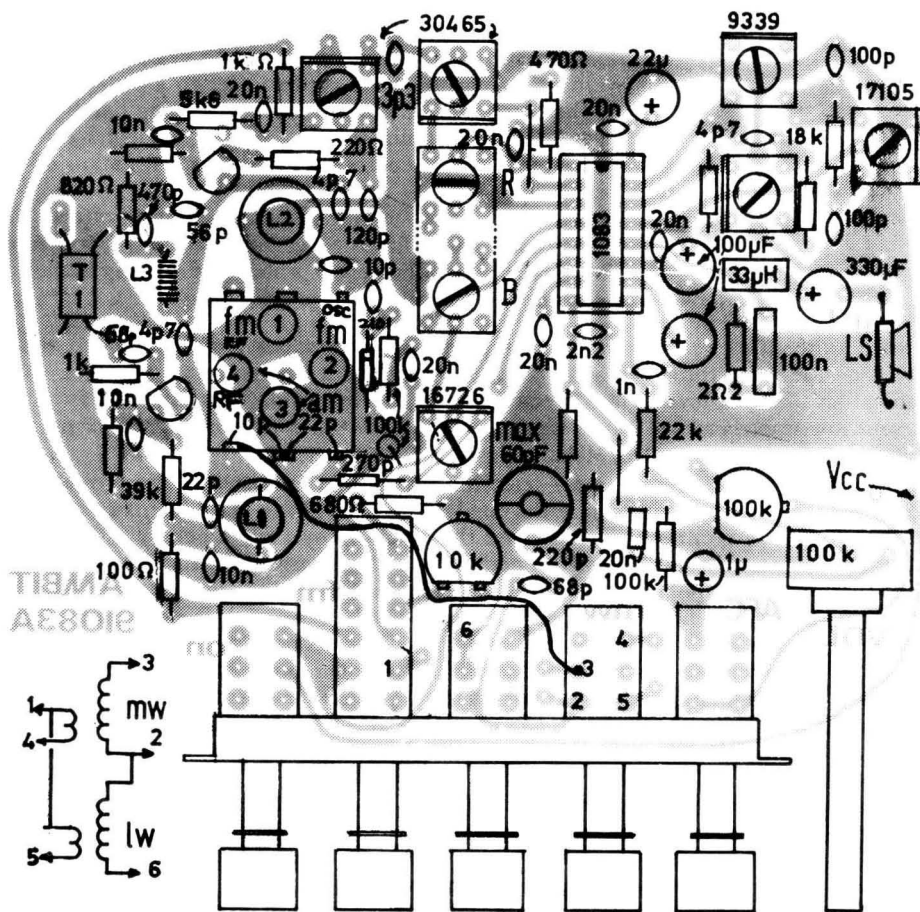

Resistors with no value assigned are not used in the basic AM/FM radio design. Additional holes are provided in the region of the AM IF filter to permit the use of the CFM2 series with appropriate matching transformers.

**T1 :**

T1, the FM antenna input transformer, is mounted with the three turn winding coupled between earth and the 68pF capacitor on the emitter of the input transistor (a BF241 or BF195). In areas where there is exceptional overloading from local transmissions by public services using midband frequencies in the 100MHz region, a 22pF placed in parallel with this secondary coupling will reduce overload interference. Strong signal handling is further assisted by use of a 1N4148 or similar diode connected as shown on the output end of the tunerhead.

## The one chip communication receiver (3)

The Audio output stage is again cleverly designed to optimize operation at low supply voltages. Where high audio level is not essential, the use of a 6v battery will provide useful economy, without affecting the RF/IF performance. In order to balance the volume when switching between AM and FM, it is necessary to adjust the relative levels by means of the detector coil damping resistors.

The final section of the IC contains a 12v zener diode, which is primarily for use in shunt regulation systems, such as the mains powered radio - where no transformer is used. This approach is frowned upon by most of the world safety standard authorities, and should not be undertaken by anyone not really fully aware of the techniques involved in isolation and insulation, since all parts of the radio chassis may be mains "Live" (as in the old AC/DC set), including the speaker, the antenna, the earphone etc.

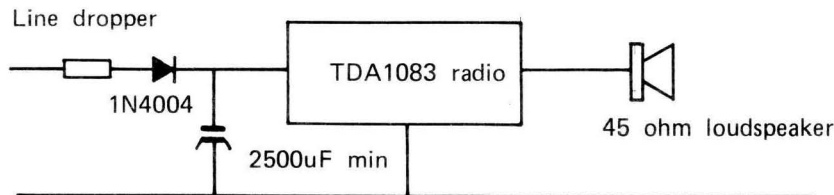

Figure three: The mains dropper system

The AF power is restricted to a maximum 150mW, since the class B nature of the AF output would mean that the voltage stability could not be maintained at greater current levels. Thus this configuration may be of use in mains powered intercom systems - but not really as a radio, where most people want more volume on tap.

### Practical considerations

In its primary "mode" a complete MW/LW and FM tuner circuit looks like

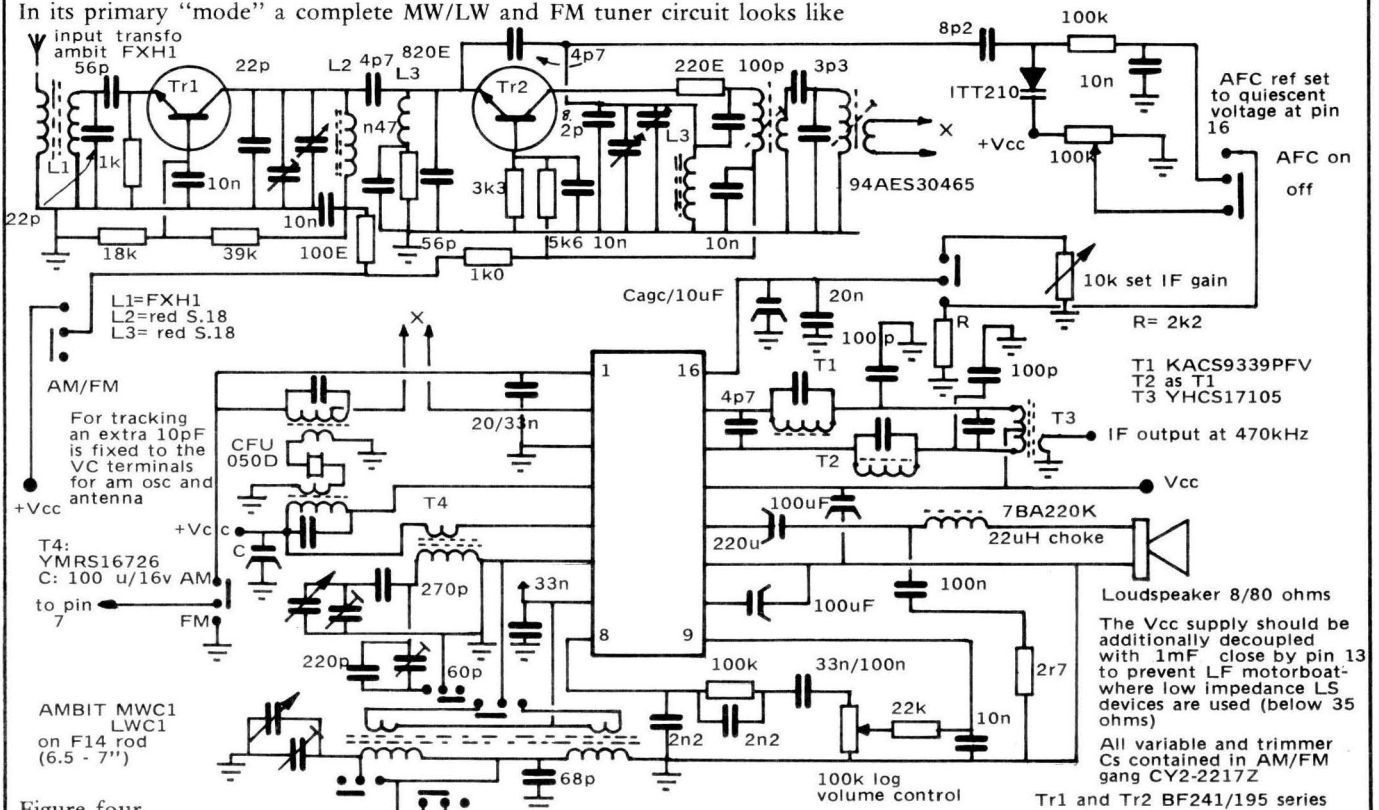

Figure four  
The complete Broadcast receiver

The FM tunerhead comprises a classical two transistor configuration, that whilst not the last word in selectivity, manages to combine a useful sensitivity (4-8uV) with sufficient selectivity for rod antenna applications. The FM tuning capacitor is contained within the TOKO polyvaricon AM/FM tuning capacitor, along with 4 trimmers - and the RF and oscillator tuned circuits are heavily padded down to provide the desired tuning range. (Otherwise, the available 20pF of swing could cover a vast range at VHF, without much hope of accurate frequency tracking.)

The RF stage uses a low FT transistor, (high FT devices tend to oscillate), in a common base configuration, that feeds directly into the ubiquitous mixer/oscillator stage, that provides oscillation and conversion to 10.7MHz where a loosely coupled bandpass pair provide a surprisingly good selectivity characteristic, when combined with the selectivity at the IF output.

From the detector stage, deemphasis (and RF decoupling) feed the audio via a 'stenode' correction circuit, where some of the missing treble is reinstated. In fact, this over pre-emphasises the detector characteristic once again, but since most loudspeakers used in such radios tend to have their own brand of deemphasis (no tweeter), the correction makes for a pleasing overall effect. The basic deemphasis capacitor must not be reduced, or IF instability may result.

Stability components in the AF output are essential, and the values shown completely remove all trace of the oscillation that integrated class B amplifiers tend to display around 15-22MHz. The 33uH choke acts as a self resonant trap, and the R/C in series provide the usual ultrasonic Zobell network.

In AM operation, the antenna used is the Ambit 476 MW/LW assembly, with impedances slightly higher than found in

## The one chip communication receiver (4)

usual bipolar transistor input stages.

### Testing and alignment with the TDA1083

Testing and alignment is delightfully simple, when compared to the usual AM/FM set. On switch on some noises must be heard on AM if the unit has been correctly assembled - and the best start point to check the circuit out is on MW. The local oscillator is set to 2075kHz (470kHz IF) at the HF end, and with antenna coil flush on the rod, the MW is just about optimized already ! The LF end should be set for 995kHz, and the antenna coil peaked on the rod, with the capacitive trimmer adjusted at the HF end of the band. A meter may be used connected to pin 16 to read the reverse AGC voltages, but the ear should be just as suitable an indicator.

The Long Wave (150 to 275kHz) is tuned in a similar fashion, except that there is no antenna trimmer provided since the basic inductance adjustment is quite sufficient to track the rod over this relatively narrow band. The LW coil is about 7.5 - 10mm from the rod end in most cases. The IF filter requires virtually no adjustment - only occasionally will peaking the Blue core have an effect.

The detector coil should be set for best AF, and with most devices, the coil does not require a damping resistor, though certain manufacturers data advocates the use of something in the region 10-22k. If too heavily damped, the audio on strong signals becomes distorted.

FM is slightly more troublesome. A 10.7MHz signal source is a useful aid to set the IF, but once again, it is possible (with patience) to adjust by ear. The oscillator coil will be approx. 3-4mm above the top of the 2½ turn S18, and the RF coil flush with the top of the S18. Such is the reliability of the S18 style, presetting the coils in this fashion has always provided sufficient initial assistance to enable further alignment to continue. It is very difficult to get completely lost in the wastes of MHz using this approach.

The FM detector coil T2 should be set for best AF, on a relatively weak signal - and then the other FM IFs can be adjusted for best quieting. With the IF aligned, the tracking procedure for the RF and oscillator coils is now a made a great deal easier, and can be carried out with the knowledge of the local transmitter frequencies as your basic datum points. Those of you with signal generators, spectrum analyzers etc. to hand, should not require further instruction on their application to this particular task. Impressive performance should result, with 5uV or better FM sensitivity, and AM sensitivity to match any other portable radio you can lay your hand on. (In the under £50 region)

Familiarity with radio design only comes with long experience. More so than other area of electronics, since there is no real "go/no go" state, as "go" is very much a matter of degree. "No go" can be obvious enough, but there will always be conditions of instability where the unit will operate delightfully well at one point, and not at all further along the band. The TDA1083 brings radio a little closer to the "Go/no go" wireless, but there are still many areas of degree of "go", so once you have achieved a satisfactory state of "go" you continue to try to squeeze a little extra out of the circuit at your peril. The last dB is always the hardest to achieve.

The MW/LW/FM receiver is a useful start point to become familiar with this device - so now let's consider the further extension of the device, and ultimately, the "one chip communications receiver."

### Extending the frequency coverage of the TDA1083 in the AM/SSB mode

The oscillator section has already been discussed at length. When correctly used, the local oscillator is good to 40MHz, and surprisingly stable in a general coverage application. The purity of the oscillator also makes a great difference to SW performance, where a low IF can cause image problems in its own right, but these images are frequently greatly confused when the primary and secondary mixing products of the oscillator harmonics are all whistling through the wireless:

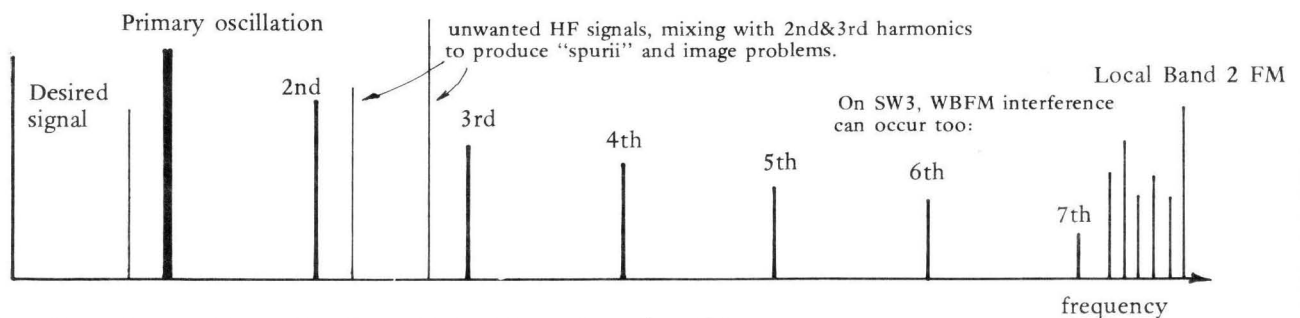

Figure four: A spectral consideration of SW mixing and spuri problems

The TDA1083 operates with the following standard TOKO coil line up:

Antenna/RF coils	Oscillator coils	Sensitivity into the IC	Frequency range
SW1 KAN333R	KAN3426R	2uV	1.6 - 4.5MHz
SW2 MTKANF2027	MTKANF2027	2uV	4 - 14MHz
SW3 KANK3335R	KXNAK3428R	4-6uV	14 - 30MHz

(No RF stage employed)

The basic application consists of simply a tuned antenna transformer, and tuned oscillator. And since the oscillator 2nd harmonic is some 50-60dB down, the harmonic image problems mentioned above are very much reduced. As a portable type of SW broadcast receiver, the performance is quite excellent for the complexity involved.

The two port oscillator allows for simple SW switching, and the only point to watch is the tendency for the local oscillator to fire on the tuned circuit represented by the coupling winding and the stray capacity. On SW1 this is a nuisance, since when the tuning capacitor is meshed, and the oscillator voltage drops, the frequency may suddenly hop to 35MHz. The cure is simple (and requires similar thinking to the same problem with the TDA1062) and that is to flatten the Q of the coupling winding, by a series resistor. 22 ohms to 100 ohm will do, and the oscillator stays correctly tuned all the time.

On higher SW bands, the coupling winding has a resonance beyond the capacity of the TDA1083 oscillator - but just in case some examples exhibit an exceptional HF performance, it is a wise precaution to include the feature on all bands.

Of course, it is quite permissible to use a ferrite rod antenna (using the correct ferrite grade F16) for up to 14MHz, and a coupling coil on the rod may be provided for external wire antennas. Some geographical areas will doubtless

## The one chip communications receiver (5)

find that LW is superfluous, and that the SW2 band is a more useful proposition. In this case, the antenna switching system will have to be re-arranged, since the effect of shorting out the SW antenna rod coil on the MW coil would be to spoil the characteristics of the MW beyond compensation. Separate switching for the tap and tuned winding is advised.

SSB is the popular means of communication at HF, and so deserves a place in any new receiver design that covers the shipping band(s). The TDA1083 is not ideally characterized for SSB, though a little thought reveals that a minor rethink of the detector circuit presents an excellent means of demodulation.

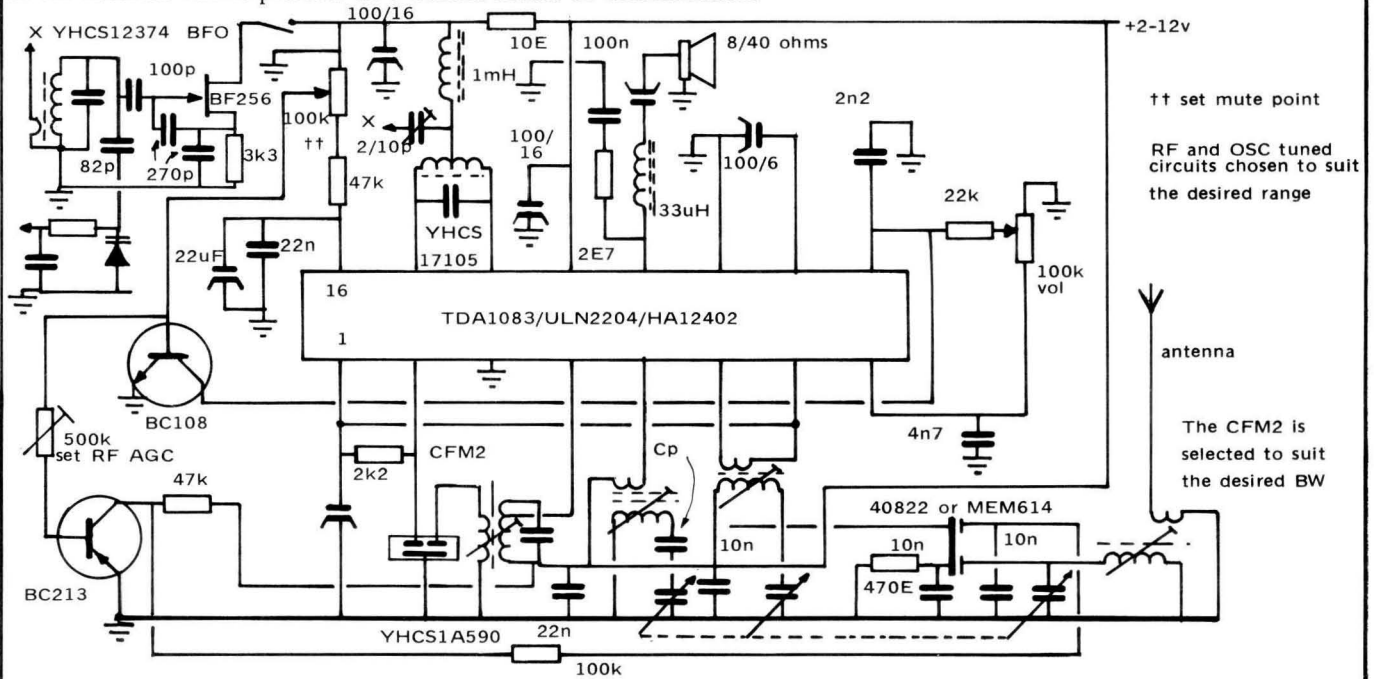

Figure five: An AM/SSB application

The amount of BFO coupled into the detector is critical - too much will flatten the AGC line and thereby destroy the sensitivity. A few pF of coupling is generally all that is required.

The stability of the TDA1083 local oscillator is affected by fluctuating signal levels, via the AGC line, and it is a shame that there is no apparent means of killing the AGC and putting the IF into a limiting mode for SSB - since that also turns off the oscillator. However, an externally injected LO at pin 5 would be quite acceptable, and should prove immune to the effects of the AGC line, which may then be tailored to suit the mode of reception, remembering that it is accessed via pin 16 of the IC. Heavily limited SSB may not sound Hi-Fi, but it has a useful communications quality, which is the prime concern of the mode.

An RF stage with AGC - a dual gate MOSFET is ideal - will give the overall performance a boost of some 20dB- which produces a 1uV/26dB performance in the HF. At this sort of level of gain, a series tuned IF trap (YMCS2a740) at the input pin 6 is a useful precaution, since the small amount of IF currents circulating in the earth paths may be big enough to cause feedback instability at IF frequencies.

The thought will by now have occurred to many that the device lends itself to use VHF receivers, where dual conversion is practised from 10.7MHz to 455kHz. Simply use the above circuit with the appropriate filter bandwidths for the modes desired. The internal oscillator may be used to interpolate around the second conversion frequency of 10.245MHz, or an external crystal controlled oscillator injected at pin 6 may be suitable.

The NBFM mode is simply achieved by using 455kHz tuned circuits at pins 15 and 14. The impedance should be matched using secondary winding coupling for the final IF, and the AM peak detector coil must be omitted, leaving the operating mode fixed, unless PIN diode switching considered worth the effort to achieve "all mode" facilities.

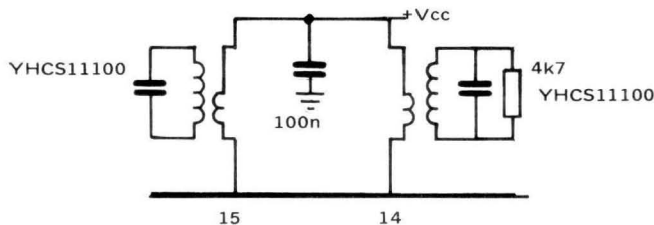

Figure 6: Detector arrangement for NBFM operation

### Further hints etc

The device is still a relative newcomer, and so applications will continue to appear as engineers start to get to grips with the many aspects of this versatile IC's capabilities. The following are offered as ideas, and have yet to be fully investigated and documented:

Metal locator systems: DC coupling means operation from VLF to HF, use for either IB/BFO or phase angle systems (with the correct detector) plus on-chip audio

TV sound IFs, mains carrier intercomms, optical communications, - please submit any ideas you may have to add to the list.

No originality is claimed for these amazing revelations, but it is surprising how infrequently they are published:

Impedance, Z, is related to L, C and Q in the following expressions:

$$Z = Q_u \cdot X_l = Q_u \cdot 2 \cdot \pi \cdot f \cdot l \quad \dots 1$$

where f is the tuned frequency in Hz and l is the inductance in Henrys

$$\text{and } Z = Q_u \cdot X_c = \frac{Q_u}{2\pi \cdot f \cdot C} \quad \dots 2$$

C is expressed in Farads.

Q is largely dependent on the core and bobbin materials - together with the DC winding resistance:

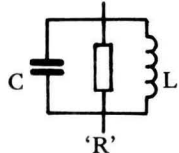

$$Q = \frac{R'}{\omega L} \quad \dots 3$$

in fact, the analysis is a great deal more detailed, but the formulae given here will be quite sufficient for most of the practical situations that confront the circuit user.

Working an example from the TOKO IF range, take the LMC4202A 7mm 455IF:

$$Q = 105 \quad \text{total turns } 208$$

$$C = 150 \cdot 10^{-12}$$

so, from (2) above

$$Z = \frac{105}{2 \cdot \pi \cdot 455 \cdot 150 \cdot 10^{-9}} = 244k\Omega$$

(all calculations used here will be rounded off for ease)

Fine, but most transistor and ICs need to work into much lower impedances than that, so a little transformer theory is necessary to lower Z to the more usual collector load, of say 37k.

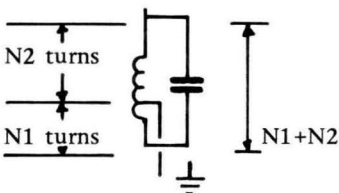

Autotransformer tapping

The total tap point impedances are related by

$$\frac{Z_{\text{tap}}}{Z_{\text{tot}}} = \left[ \frac{N_1}{N_1 + N_2} \right]^2$$

So, using our 37k value for Ztap:

$$\frac{37}{244} = \left[ \frac{N_1}{208} \right]^2$$

$$N_1^2 = \frac{208^2 \cdot 37}{244}$$

$$\text{so } N_1 = 80$$

in fact, TOKO use 74 turns, but that isn't going to make a great deal of difference in practise.

The base coupling also requires a lowered impedance, and since it is not really desirable to employ another autotransformer type of tapping, a coupling secondary is used, where the primary and secondary are so tightly coupled, that the basic analysis may be considered identical to that used in the autotransformer case.

In the case of the coil used here, the coupling is used for the detector - so a reasonably high value of 12k is used;

$$\frac{12}{244} = \left[ \frac{N_1}{208} \right]^2$$

$$N_1^2 = \frac{208^2 \cdot 12}{244}$$

thus N1 = 46 turns - and in this instance, the actual value used is 42 t.

The slight differences that occur are due to certain intentional mismatch conditions, designed to reduce the loaded Q. These considerations will be dealt with in greater detail in the next issue of Tecknowledgey.

In a perfectly matched system, the gain of an amplifier stage can be calculated from the following:

$$A_v = \frac{V_{\text{out}}}{V_{\text{in}}} = K \cdot g_m \cdot R_{\text{load}} \cdot N \cdot K$$

where N is the turns ratio  $\sqrt{\frac{Z_{\text{sec}}}{Z_{\text{pri}}}}$

K represents the 6dB match loss at both input and output gm is the transconductance in mho (reciprocal ohm) Rload is the load impedance

In the example used so far, the gain of the final IF before the detector would be:

$$= \frac{1}{2} \cdot g_m \cdot 37k \cdot \sqrt{\frac{12}{244}} \cdot \frac{1}{2}$$

with a gm of 90mmho:

$$= 184 \text{ or } 45.3\text{dB}$$

The impedance may also be altered by a damping resistor; a popular means of lowering the Q and thereby stabilizing IFs that "take off" due to too much gain. Say to reduce a Q of 105 to Q of 40.

$$\text{then } Z = \frac{40}{\omega \cdot 150 \cdot 10^{-12}}$$

$$= 93k\Omega$$

so to reduce our example, a parallel resistor is used, where

$$\frac{1}{93k} = \frac{1}{244k} + \frac{1}{R_{\text{damp}}}$$

$$R_{\text{damp}} = 150k\Omega$$

**Loading considerations**

The loading of a tuned circuit of the type described here is first calculated by changing the tap impedance to a function known as the equivalent loading resistance, derived from the equivalent circuit:

The equivalent circuit:

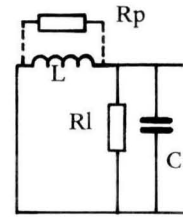

$$\text{Now } Q_l = R_p \parallel R_l \cdot X_c$$

$$\text{or } = \frac{R_p \parallel R_l}{X_l}$$

as you might expect, Rl is taken from a similar transformation formula to the ones used so far:

$$R_l = \left[ \frac{N_1 + N_2}{N_1} \right]^2 \cdot \text{Input impedance}$$

with the example before

$$= \left[ \frac{208}{74} \right]^2 \cdot 37k$$

$$R_l = 294k$$

$$\text{so } Q_l = 244 \parallel 294 \cdot X_c$$

$$244 \parallel 294 = 133.3k\Omega$$

$$Q_l = \frac{133,300}{2332} = 60$$

but dont forget the loading by the secondary winding !

$$R_l = \left[ \frac{208}{42} \right]^2 \cdot 12k = 294k$$

now this is the same as Rl for the autotransformer tap, indicating that the optimum Rp would be 294k also.

$$\text{Now } Q_l = 244 \parallel 294 \parallel 294 \cdot X_c$$

$$Q_l = \frac{91,734}{2332} = 39.3$$

which isn't far from the stated figure of 40.

So, to summarize the results:

$$Z = R_p = Q_u \cdot X_l = Q_u \cdot X_c$$

$$\frac{Z_{\text{tap}}}{Z_{\text{tot}}} = \left[ \frac{\text{Tap turns}}{\text{Total turns}} \right]^2$$

$$\text{Gain} = \frac{1}{2} \cdot g_m \cdot R_{\text{load}} \cdot \frac{\text{Tap turns}}{\text{Primary turns}} \cdot \frac{1}{2}$$

The two "1/2" multipliers refer to the 6dB loss associated with input/out termination. It will be seen from the loaded Q formulae, that under best matching conditions, when all equiv. load impedances are the same, the Q is reduced to a Ql of (1/2 \* 1/2) Qu. Since Q is directly related to V in a tuned circuit, this also implies the voltage is reduced by the (1/2 \* 1/2) factor.

$$Q_l = R_p \parallel R_l \cdot X_c = R_p \parallel R_l \cdot X_l$$

$$\text{and } R_l = \left[ \frac{\text{Total turns}}{\text{Tap turns}} \right]^2 \cdot \text{Input imp}$$

Z = R in this feature - not to be confused with basic DC resistances.

Bandsread calculations for RF tuned circuits may look fearsome - but as long as a reasonable scientific calculator is used, the answers involve little difficulty.

The basic reason for bandsread in HF and communications receivers is simple: consider a general coverage application on SW3 (14MHz to 30MHz), and now think about the degree of electromechanical stability that is demanded of such a system when trying to resolve an SSB signal, where the carrier needs to be reinserted to within 50Hz. 50Hz on the basis of a coverage of 16MHz represents about one part in three million. This is not an easy task to achieve in terms of mechanical stability and tuning resolution on a dial where they may be only five to ten turns coverage. So the answer is to use a fine tuning capacitor connected in parallel across the main tuning capacitor, but having a greatly reduced capacitance - say one twentieth of the value of the main tuning gang.

This approach is fine in many applications, but does not really solve the problem where long term electro-mechanical stability is essential. It merely facilitates the vernier tuning by the operator.

So the next technique is the expansion of the band to absorb the whole range of the main tuning gang - say 360pF - over a relatively small RF space, as in the type of receiver that covers 'amateur' bands, or broadcast bands only. In this way 21 to 21.5MHz is made to take up all 366pF of the tuning gang swing instead of just a pF or two. This means that small changes in the tuning capacitor due to mechanical shock, heat etc., are greatly buffered in terms of the final frequency shift.

Examples:

The tuned frequency of L/C parallel circuit is given by

$$f = \sqrt{\frac{25330.3}{L.C}}$$

Where f is in MHz  
L is in microhenrys  
and C is in pF

(Derived from  $f = \frac{1}{2\pi\sqrt{LC}}$ )

So, in the general coverage application, to reach 30MHz with a minimum tuning capacity of 30pF - to allow for strays, trimmers etc - the inductance required is only 0.9uH (approximations will be used to avoid unnecessary decimal complications.)

so at 21.5MHz, a capacitor of 61pF is required, and at 21MHz, a value of 64pF in other words, a change of only 3pF covers 500kHz at 21MHz. It isn't difficult to see that the mechanical susceptibility of such a system is very poor.

So in the process of spreading the band, the endeavour is to make all 366pF do the work of 3pF, and thus make all minor changes in C insignificantly small.

**The basic considerations in bandsread calculations**

In a tuned circuit arrangement that employs a variable capacitor for tuning (as nearly all outside car radios do), the frequency range covered is determined by the ratio of the maximum and minimum (including strays) capacity that appears across the inductance of the tuned circuit.

The required capacitance ratio, R,

$$(d^2) = \left[ \frac{\text{Max frequency}}{\text{Min frequency}} \right]^2 \quad (A)$$

let V = capacitance ratio of the tuning capacitor  
Cv = maximum value of tuning capacitance  
Cp = total parallel capacitance across tuning cap.  
Cs = capacitance used in series with tuning cap.  
BW = tuning range

$$\text{and BW} = [d-1] \sqrt{\frac{f_{\text{max}} \cdot f_{\text{min}}}{d}} \quad (B)$$

**Parallel capacitors**

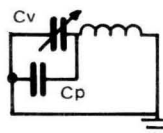

There are two basic approaches to the techniques of electrical bandsread - for a variety of reasons, the usual result is a combination of the two, since the impedance of the tuned circuit is very low with a high value of parallel capacity - and thus not suited to many oscillator applications - or very high with a large value of inductor, where the stray capacities inherent in PCBs and wiring limit the overall tuning range through a tight restriction on the factor 'V' (Capacitor ratio)

$$C_p = \frac{C_v (V-R)}{V(R-1)} \quad (C)$$

$$D = \frac{V(C_v+C_p)}{VC_p+C_v} \quad (D)$$

Now at the lowest frequency, the total tuning capacity is  $C_t = C_v+C_p$

As an example, take an interpolation oscillator for tuneable IF of 10.6MHz to 10.8MHz

$$R = (1.02)^2 = 1.04$$

Using a BB104 varicap over a range of 2 to 10v bias

C min is 12.5pF, and Cmax is 22.5pF so

$$V = \frac{22.5}{12.5} = 1.8$$

$$C_v = 22.5\text{pF}$$

substituting in (C)

$$C_p = \frac{22.5(1.8-1.04)}{1.8(1.04-1)} = 237.5\text{pF}$$

So, in order to leave room for strays, use 220pF fixed 5% with a 2-22pF trimmer.

The value of the inductor is then derived from the basic formula for the resonant frequency, where  $f = 10.8$  and  $C = 237.5+12.5 = 250\text{pF}$

$$\text{so } L = 0.868\mu\text{H},$$

but this leaves an impedance of  $Q \cdot X_c$   
assume a Q of 100 and then  $Z = 100 \times 5.89$   
which is only 589 ohms, and not generally much use in this context.

Before moving on, the tuning bandwidth may be confirmed from equation (B)

$$\text{BW} = 0.211\text{MHz (since approx. are used)}$$

So, the series capacitor method comes next:

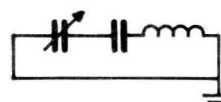

This approach relies on the principal that a small capacitor placed in series with the Cv factor will reduce the effective parallel capacity across the tuned circuit to value that is

$$\frac{1}{\frac{1}{C_s} + \frac{1}{C_v}}$$

Using the various factors already discussed

$$C_s = \frac{C_v(R-1)}{V-R} \quad (E)$$

(series C bandsread....)

the capacitance ratio, R

$$= \frac{VC_s + C_v}{C_s + C_v} \quad (F)$$

The total effective C across the tuned circuit is also derived from

$$C_c = \frac{C_v(D-1)}{V-1} \quad (G)$$

The example used will be based on the same problem so Cs

$$= \frac{22.5(1.04 - 1)}{1.8 - 1.04}$$

$$= 1.18\text{pF}$$

leading to L

$$= 201\text{uH}, \text{ and with a } q \text{ of } 100$$

$$Z = 1.34 \text{ Mohm}$$

which is just about as unlikely as the result for basic parallel capacitor. The stability demands on the series capacitor are quite impossible to achieve - and no account of stray capacitance has been made. So, to strike a useful medium, it is not surprising to find that a combination of the two methods is used.

**The Series/parallel technique**

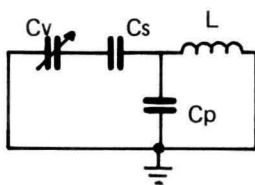

The circuit may be analyzed from a combination of the preceding formulae ((A) to (G)), using a mid-band value for the circuit impedance that is going to result in practical values and tolerances, or the following additional equations, which reduces the task to one of programming your calculator, and thinking of a few numbers:

- Cta = Total maximum capacitance
- Cps = Parallel capacitance
- Ccs = Series capacitor
- A = Intermediate capacitance ratio of the series arm of the network

and A is between the values of V and R

$$A = \frac{VC_s + C_v}{C_s + C_v} \quad (H)$$

$$C_{pa} = \frac{C_v(A-1)(A-R)}{A(R-1)(V-1)} \quad (J)$$

$$C_{ta} = \frac{RC_v(A-1)^2}{A(R-1)(V-1)} \quad (K)$$

$$\text{or } C_{ta} = C_{pa} \cdot \frac{RC_v(A-1)^2}{C_v(A-1)(A-R)} \quad (L)$$

The value of A is found by introducing a few more variables:

$$C_j = 2RC_v \quad \text{then}$$

$$C_k = C_j + C_{ta}(R-1)(V-1)$$

$$\text{and } A = \frac{C_k + \sqrt{C_k^2 - C_j^2}}{C_j} \quad (M)$$

which leads to

$$C_s = \frac{C_v(A-1)}{V-A} \quad (N)$$

Now this technique is by far the most widely used in design and tracking of resonant circuits - and in the example used so far, where

$$R = (1.02)^2 = 1.04$$

$$V = 1.8$$

$$C_v = 22.5\text{pF}$$

Cta = chose a value that makes some practical sense here, say for Z of 10k ohms at 10.6MHz 150pF, which is quite manageable sort of choice, as the L is from

$$L = \frac{25530.3}{150(10.6)^2} = 1.5\text{uH}$$

the approx. value for A from (H)

$$C_j = 2 \cdot 1.04 \cdot 22.5 = 46.8$$

$$C_k = 46.8 + (150[1.04-1][1.8-1]) = 51.6$$

$$A = 1.5669$$

$$\text{so } C_s = \frac{22.5(1.5669-1)}{1.8-1.5669} = 54.72\text{pF}$$

The series capacitor is selected to be 56 pF in this instance bearing in mind it is going to be a great deal more satisfactory to place any trimming C in parallel, where one side will be RF earth to permit adjustments without stray errors.

Plugging this back into (H)

$$A = \frac{(1.8 \cdot 56) + 22.5}{56+22.5} = 1.57$$

$$C_{pa} = \frac{22.5(1.57-1)(1.57-1.04)}{1.57(1.04-1)(1.8-1)} = 135.3\text{pF}$$

$$(A-1)^2 = 0.325$$

$$\text{so } C_{ta} = \frac{1.04(22.5)(0.325)}{1.57(1.04-1)(1.8-1)}$$

$$= 151.37\text{pF}$$

which confirms the original conditions

To allow for a trimmer, the final choice should be:

$$C_s = 56\text{pF}$$

$$C_p = 100\text{pF}$$

$$C_{trim} = 0-60\text{pF (in parallel with } C_p)$$

remember that the distributed capacitance of the inductor will account for a few pF in Cp section of the equations- but this is not appreciable until layer wound LF coils are employed.

**Alternative Parallel/series method**

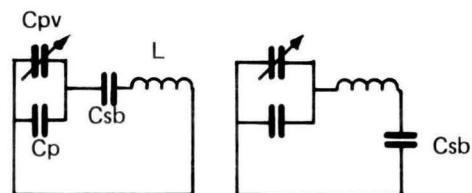

Csb = series capacitance

Ctb = total maximum capacitance

Cpv = max C in parallel arm

B = intermediate cap. ratio in parallel arm only (again, between V and R)

$$B = \frac{V(C_v + C_p)}{C_v + VC_p} \quad (O)$$

$$C_{sb} = \frac{BC_v(V-1)(R-1)}{V(B-1)(B-R)} \quad (P)$$

$$C_{tb} = \frac{BC_v(V-1)(R-1)}{V(B-1)^2} \quad (Q)$$

As  $C_{sb}$  will be fixed,  $C_p$  is solved using intermediate variables:

$$C_q = 4V \cdot C_v \cdot \left[ \frac{C_{sb}(V-R)}{R-1} - C_v \right] \quad (R)$$

$$C_r = C_v(V+1) + VC_{sb} \quad (S)$$

$$C_p = \frac{\sqrt{C_q + C_r^2} - C_r}{2V} \quad (T)$$

*(It should be noted that all these various formulæ are basically algebraic manipulations of the basic LC resonance equation—and so derivations are not given here for reasons of space)*

For a change, the example used here will relate to something different - coverage of the MW with the KV1210 varactor triplet. Reference to the data sheet of the KV1210 shows that from 2 to 9v bias, the capacity swing is from 400pF to 30pF typically (per diode)

$$\begin{aligned} V &= 400/30 = 13.33 \\ C_v &= 400\text{pF} \\ BW &= 1605/525 \text{ kHz} \\ R &= BW^2 = 9.35 \end{aligned}$$

So take  $C_{sb} = 10000\text{pF}$  and insert in the formulae:

$$C_q = 4 \cdot 13 \cdot 400 \left[ \frac{10000(3.65)}{9.35-1} - 400 \right] = 8.26 \times 10^7$$

$$C_r = 400(13+1) + 13(10000) = 135600$$

$$\text{so } C_q + C_r^2 = 1.847 \times 10^{10}$$

$$\text{and } C_p = \frac{1.36 \times 10^5 - 135600}{2 \times 13} = 17\text{pF}$$

as far as the RF sections of the MW are concerned, then  $C_p$  is simply a 7/35pF trimmer, set halfway and trimmed to take up strays.

The inductance at a  $C_t$  of 417pF and a frequency of 525kHz is then

$$= \frac{25330.3}{417 \cdot (0.525)^2} = 220\mu\text{H}$$

which should also occur at 1605kHz and 47pF

$$= \frac{25330.3}{47 \cdot (1.605)^2} = 217\mu\text{H}$$

(The slight error is due to use of 400pF without taking into account the effect of the 10000pF in series)

The final part of this series of bandsread and tracking details will appear in the next issue - it concerns the tracking of the local oscillator at (signal frequency + IF) and covers both parallel gangs (where both the antenna(e) and oscillator sections of the tuning capacitors are the same) and non-parallel gangs eg 160+80 pF, as often found in imported MW only radio applications

### In the next issue of Tecknowledgy:

At the time of writing this, all consideration of the next issue seems the height of folly - after all, this issue has been delayed for a string or reasons, but primarily because we have been busier for the time of the year than we anticipated, and we want the whole production to be carried by Ambit staff who are aquainted with the products - and generally in the "thick of things". We have not managed to get in all we wanted to - so additional supplements are going to be produced on things such as

- \* The Radiometer Ferret
- \* The PCB/dalo pens
- \* Databooks
- \* Hardware including tuning pots etc
- \* Spaghetti farming in Tuscany

### But in the next issue proper.....

All that's new and wonderful in radio ICs, we hope to include details of the first Europeanized frequency synthesiser for FM and AM, some improved DFM chips (and ways to remove their RFI problems). A full report on the new family of noise blankers, introduced for the first time in this issue with the KB4423.

Words and details of UHF tunerhead techniques, with a TV preamp (tuneable) with printed inductors. But since we aim to keep as up-to-the minute as possible, it is difficult to predict much more than that.

We would appreciate any contributions from our readers/customers. These will be assessed quickly, and payment will be made on acceptance. The features must naturally relate to modern techniques, and modern components with a main theme of radio - or based on products appearing in our catalogue/price list. We particularly invite articles on the following:

Switching radios with the MA1012/MA1023  
Use of the TDA1083 in communication type circuits.

The KB4423 as a record scratch blanker/ IF noise blanker at IF frequencies.

A perpetual motion device that works.

### PS:

We know about the wonder decoder announced in April WW - the TCA4500A - and have given it a check. At present, we think its fine for car radio, but overall, the HA1196 is superior in all normal tuner applications. In fact, the HA1196 can be fitted with variable blend with a simple FET voltage dependant resistor in the separation circuit. A new IC from Hitachi with .02% stereo THD and 86dB S/N is likely to be our next decoder feature, when available. But all this is bit acedemic when you consider broadcast standards at the transmitter don't promise better than some 65dB S/N and we have heard of one BBC station broadcasting 3% THD, which was later reduced when they found out!

Trends seem to be towards Dolby broadcasting, and it can already be usefully employed in conjunction with certain IBA stations who we think are already testing. The BBC variable pre-emphasis technique also benefits from a Dolby approach to de-emphasis.

**This issue is something of new concept of combining sales promotion with feature articles (original ones, that is) and so we would like to know what you think of it.** The editorial on page 3 sets out our basic approach, namely this is a magazine for engineers, by engineers who can still remember which end of the soldering iron gets hot. Do you want more basic radio reference theory, cut out from transmission line principles that most humble wireless followers don't ever really use? Is it too boring? Has it been of any use? Would you buy another?

By using the term "engineers" we try to encompass both the professional, and of course the enthusiast, and since these are frequently the same creature - we don't really think a distinction in terms is necessary. There is certainly a distinction in terms of basic knowledge and experience, but since we know many hobby enthusiasts who know a whole lot more than many professionals, the choice of terms is difficult if one or other of our two main readerships is not to feel insulted. You're all really very wonderful.

Well, almost. Well, compared to the first synthesized HF receivers, this one is a revelation. All right then, it *does* use more than four ICs, six if you count the synthesiser 6 station dynamic memory and divide-by-100 prescaler. This feature is based on work carried out at *Ambit* in anticipation of low cost integration developments in radio at last beginning to catch up with those in data processing. Basically, it's an idea - one we are working on here at present - to revolutionize the general approach to consumer radio, bring standards up to communications levels without costing the earth. So far, results have justified our hopes - more will be told in the next issue:

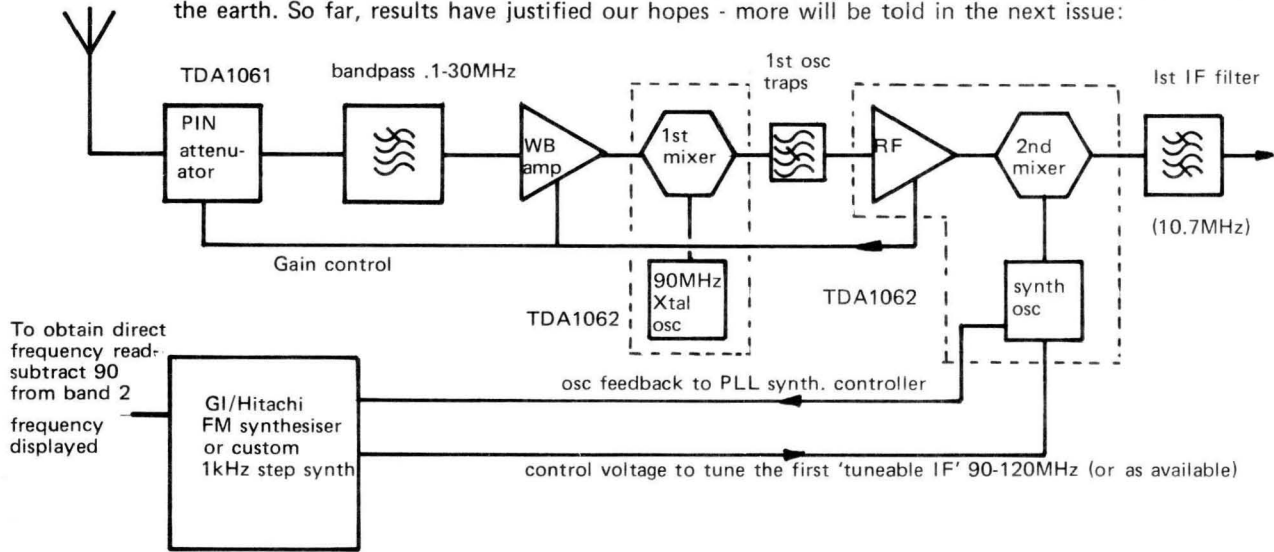

To obtain direct frequency read-subtract 90 from band 2 frequency displayed

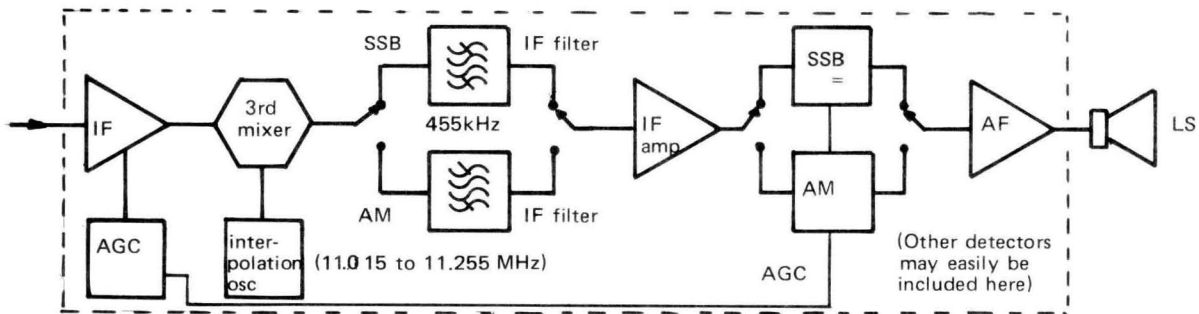

TDA1083

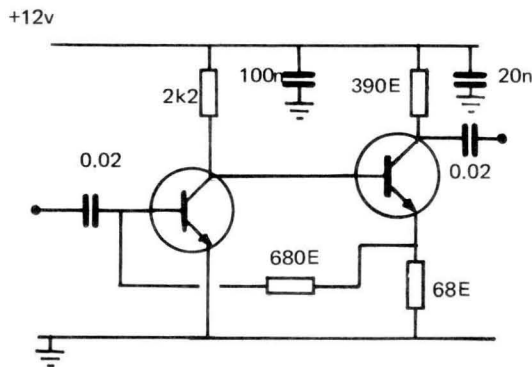

A wideband RF amplifier having a voltage gain of 24dB and a spot noise figure of 3.5dB at 100MHz. The upper -3dB point is 160MHz for 2N3570 transistors, largely dependant on component lead lengths. Use of new devices, such as the BF479 should result in superior results, with greatly reduced noise and improved gain. (Remember to invert the supply for PNP devices). In fact, the basic BF274 will be quite good enough for HF use.

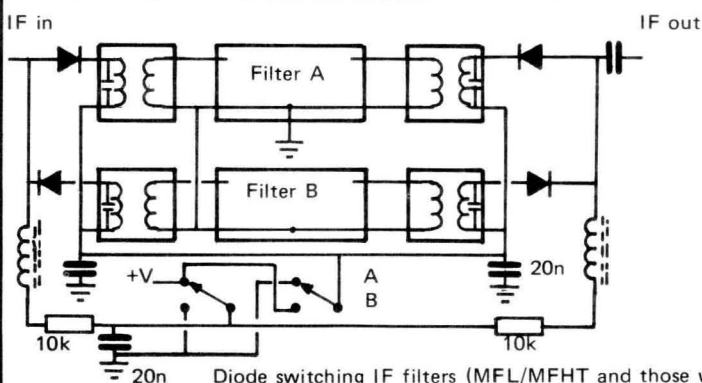

Diode switching IF filters (MFL/MFHT and those with input/output IFs)

All this may look fearsome - but consider the block diagram of £10 scientific calculator - probably a great deal more complex than this is. All of which serves to illustrate our point, and that is that now that ICs and MPU based processing are beginning to get to grips with low cost radio synthesisers, the technology is ready for exploitation in other ways. The dotted lines outline the three major signal processing ICs, two TDA1062, and one TDA1083. All possess fully balanced mixers, wide dynamic ranges and low cost. In fact, they probably outperform many devices in current use in some exotically priced communication receivers.

*Description of operation*

From the antenna stage, a TDA1061 constant impedance PIN attenuator precedes that main bandpass filter that restricts the input range to the wideband RF stage to 100kHz to 30MHz. This passes onto the first mixer - a TDA1062 is shown here, though an MC1496 may be preferred in the final design - which is fed oscillator from a 90MHz crystal oscillator. So that  $90\text{MHz} + 100\text{kHz} = 90.1\text{MHz}$  and  $90\text{MHz} + 30\text{MHz} = 120\text{MHz}$  which are covered in the next stage, a modified band two front end, based on the TDA1062, and using all its functions, including the pin attenuator drive. The agc line should have manual interception available - and maybe better derived further down the selectivity line to prevent blocking due to AGC action on strong adjacent carriers. On SSB, an audio derived signal processed via one LM3900 may be used in addition. Moving on, the IF output may be 10.7MHz exactly - provided the synthesiser is capable of sufficient resolution - say 1kHz. However, the problems of settle-down time and jitter would mean a fairly costly approach, so the low cost answer is to accept the commercial FM synthesiser, with its 200kHz channel spacing, and 'Interpolate' by making the final IF tuneable from 10.6 to 10.8MHz. The TDA1083 can then provide virtually all the last IF/audio functions, feeding via the appropriate low cost 455kHz mechanical filter to a variety of detectors. Now, that wasn't so difficult, was it? And the result is an approach to a communications receiver that should cost less than a bandswitched version in production. Alignment is cut right down, ready built "plug in" modules may be used.

Equipment boxes in Black ABS

**BOXES**

- \* Flanged lid
- \* Four screw fixing
- \* Excellent value

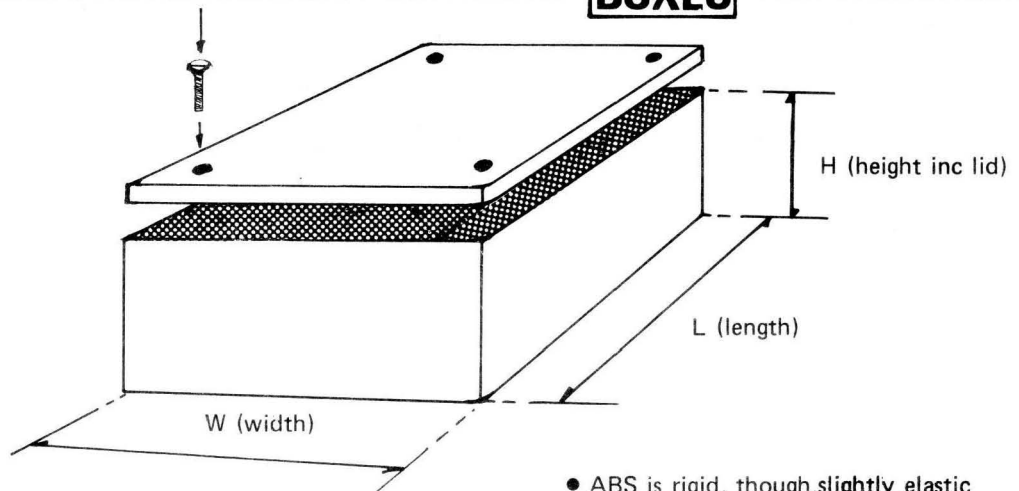

Dimensions: in mm

MB	W	H	L	price each
1	56	37	77	0.54
2	71	35	95	0.66
3	95	37	115	0.76

The following is ABS vacuum formed for potting purposes - no lid supplied

4	50	15	50	0.29
---	----	----	----	------

● ABS is rigid, though slightly elastic plastic, especially suitable for punching and drilling without the problems that are associated with the cheaper and more brittle styrenes.

**Specification 8001**

Input range 100 - 600mV RMS (optimum 180mV)  
 output adjustable with overall x 4 gain (voltage)  
 supply +12v  
 Response : within 1dB to 55kHz, -30dB at 200kHz.

Circuit diagram of 8001 "birdy filter"

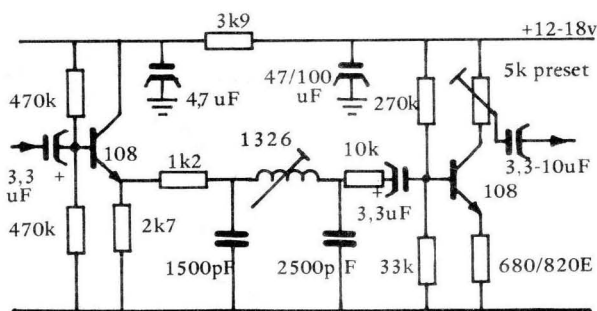

emitter follower input stage      π filter network (Fc = 60kHz)      output amplifier (gain approx 10x)

Where to fit the 8001

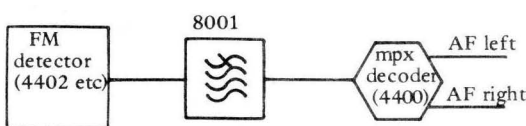

**The 8001 MPX Birdy filter**

**General**

The FM broadcast band is divided up into a series of channels 200kHz apart. (With a few minor exceptions in remote low powered relay station transmitters.) Whilst the mono broadcast spectrum occupies some 15kHz of AF bandwidth, the stereo Zenith-GE multiplex system requires 55kHz to contain the following : Pilot tone at 19kHz (generally 10% of system deviation, about 8kHz) DSB sub carrier at 38kHz DSB modulation bandwidth, making a total AF bandwidth requirement of some 55kHz.

This places a requirement on the FM detector for a linear bandwidth very much greater than has been the case for mono - and it also means that the preceding IF selectivity stages must not restrict the passage of the extremes of the IF signal. Nor should any phase distortion occur, which would have the effect of altering the group delay of the IF signal, so that the Left minus Right channel information contained in the 38 kHz sub carrier becomes out of phase with the 19kHz pilot signal, which is used in the decoder to accurately reconstruct the missing 38kHz carrier. (Thereby reducing the channel separation attainable in the system.)

One of the problems brought about by the increase in FM bandwidths is that interchannel interference cannot now be prevented by simply narrowing down the IF bandwidth. So in certain areas where adjacent channel interaction occurs, the only satisfactory answer is to employ the extra selectivity after the detector stage, in the form of a 55kHz low pass filter.

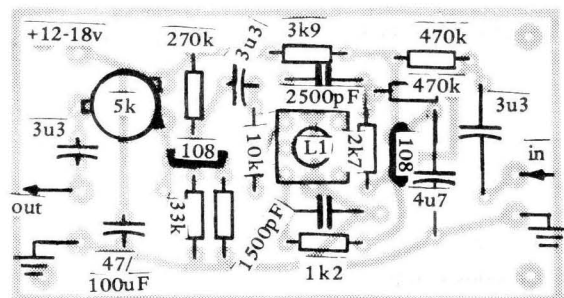

# MA1012 LED display digital electronic clock module

## connection diagram

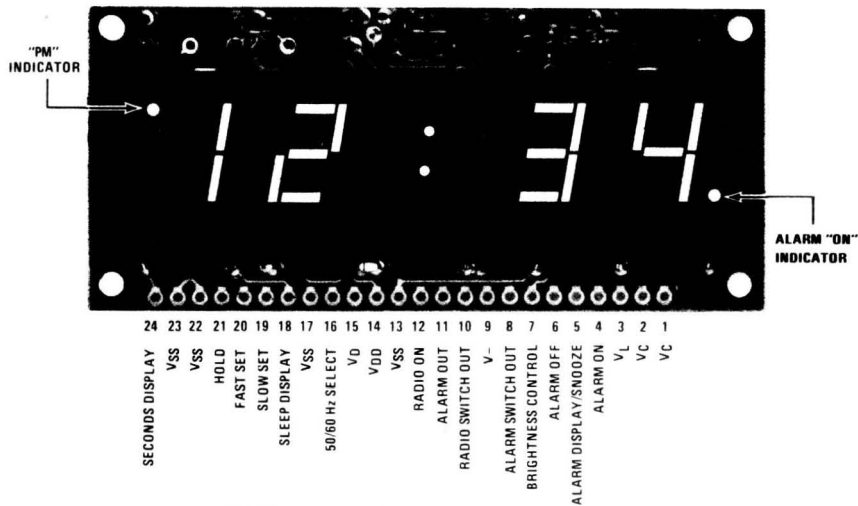

## general description

The MA1012 Series Electronic Clock Modules combine a monolithic MOS-LSI integrated clock circuit, 4-digit 0.5" LED display, power supply and other associated discrete components on a single printed circuit board to form a complete electronic clock movement. The user need add only a transformer and switches to construct a pretested digital clock for application in clock-radios, alarm or instrument panel clocks. Timekeeping may be from 50 or 60 Hz inputs and 12 or 24 hour display formats may be chosen. Direct (non-multiplexed) LED drive eliminates RF interference. Time setting is made easy through use of "Fast" and "Slow" scanning controls.

Features include 150 mA radio supply switch, alarm output switch, alarm "on" and "PM" indicators, blinking colon, "sleep" and "snooze" timers and variable brightness control capability. Power failure is indicated by flashing the display at a 1 Hz rate.

## features

- Bright 4-digit 0.5" LED display
- Complete - add only transformer and switch
- 150 mA radio B+ switch
- Alarm output switch
- 12 or 24 hour display format
- 50 or 60 Hz operation
- Power failure indication
- Brightness control capability
- "Sleep" and "snooze" timers
- Alarm "on" and PM indicators
- Direct drive - no RFI
- Fast and slow set controls
- Low cost, extremely compact design

## absolute maximum ratings

Voltage - Pins 15 to 13	20 Vrms
Voltage - Pins 1, 2 to 13	7.0 Vrms
Voltage - Pins 9 to 13	+0.3 to -26V <sub>DC</sub>
Voltage - Pins 8, 10 to 9	30 V <sub>DC</sub>
Operating Temperature Range	-25°C to +70°C
Storage Temperature Range	-65°C to +85°C
Lead Temperature (Soldering, 10 seconds)	300°C

## electrical characteristics

T<sub>A</sub> = 25°C; Pins 15 to 13 = 16 Vrms; Pins 1, 2 to 13 = 5.0 Vrms, unless otherwise specified. Normal operating conditions allow Pins 15 to 13 to vary between 14 and 18 Vrms; Pins 1, 2 to 13 to vary between 4.2 and 6.5 Vrms.

PARAMETER	CONDITIONS	MIN	TYP	MAX	UNITS	
V <sub>DD</sub>	MOS Supply Voltage	V <sub>SS</sub> = 0V	-18	-22	-25	V <sub>DC</sub>
I <sub>15</sub>	MOS Power Supply Current	100% Display Brightness		14	18	mA <sub>DC</sub>
I <sub>15</sub>	MOS Power Supply Current	Display Off		3	5	mA <sub>DC</sub>
	LED Power Supply Current	100% Display Brightness (20:08)		250	280	mA
V <sub>DD</sub>	Power Failure Indication Voltage	V <sub>SS</sub> = 0V		-5	-8	V <sub>DC</sub>
	LED Segment Display Current	Short Pin 7 to Pin 14 (R = 0Ω)		11		mA
		R = 12K		1.2		mA
		R = ∞		0.0		mA
V <sub>CE(SAT)</sub>	Radio Output	I <sub>C</sub> = 150 mA		0.1	0.3	V
V <sub>CE(SAT)</sub>	Alarm Output	I <sub>C</sub> = 15 mA		0.1	0.3	V
	Power Dissipation	100% Display Brightness (20:08) Max Input Voltage			2.3	w

## optical characteristics

PARAMETER	CONDITIONS	MIN	TYP	MAX	UNITS
Luminous Intensity Per Segment	I = 11 mA <sub>DC</sub>	100	300		μcd
Peak Wavelength			660		nM
Spectral Width	Half-Intensity		40		nM
Viewing Angle	1/2 Brightness Point	±60			degrees
Variation - Any Two Segments	R = 0, Pins 7 to 14 R = 4.3K, Pins 7 to 14			2:1 2:1	

## physical dimensions

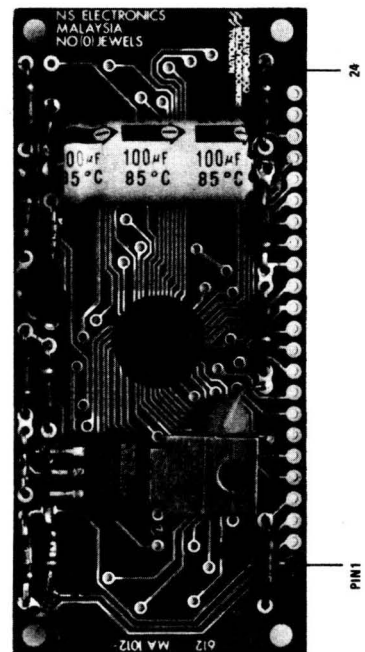
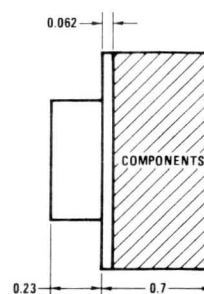
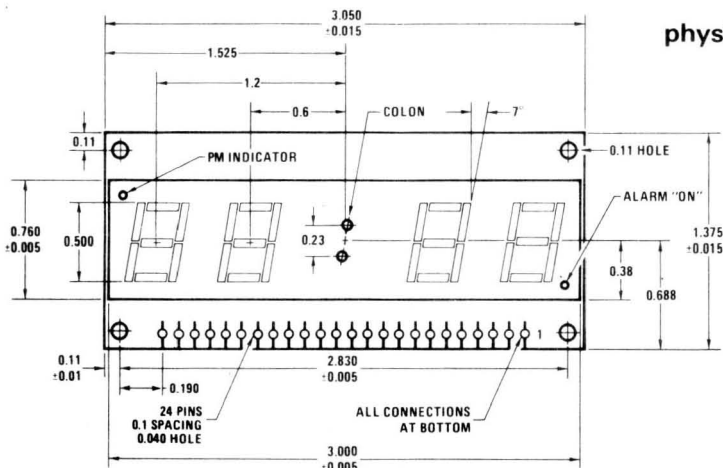

Only 12 hour module available

**FEATURES**

- \* User selectable 12/24 hour, Fixed/Flashing colon operation
- \* Direct drive (8 ohm) to alarm speaker (800 Hz gated at 2Hz)
- \* Direct drive LED display - no RFI
- \* .7 inch display
- \* 59 minute sleep counter
- \* Multiple 9 minute snooze counter
- \* 24 hour alarm
- \* Requires only transformer and setting switches
- \* Automatic display brightness control capability
- \* Back - up oscillator using a 9v battery
- \* Seconds display mode

This new National Clock module needs only the addition of a mains transformer, speaker and switches to produce a multi - feature alarm clock which may also be used as a time switch with a countdown timer of up to 59 min. Other display information gives power failure (display flashes when power is restored), alarm ON and PM indicators. The device also includes a back - up oscillator for use in the event of a power failure, driven from an external 9v battery.

Display setting is achieved by fast and slow setting inputs, and an additional input 'time set lock out' prevents accidental time setting without inhibiting alarm and timer setting.

Maximum flexibility is provided by user programmable 12/24 - hour display, 50 or 60 Hz input and fixed or steady state activity indicator (central colon). In addition display brightness level can be varied with a 10K ohm pot or a S.P.S.T. switch for bright/dim modes. Outputs from the module are Alarm and Timer, the alarm is an 800 Hz signal modulated at 2 Hz, and can drive directly an 8 ohm speaker. The timer output is an uncommitted P.N.P. transistor which may be used to switch external circuits.

(Further data supplied with device or available on request)

MA 1023 pin layout (smaller than actual size)

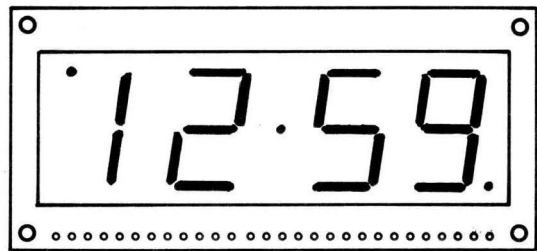

L. 84mm  
W. 34mm  
D. 16.25

- 1 Vled
- 2 Vled
- 3 Battery
- 4 Vac
- 5 Vled
- 6 Display dim
- 7 Vss
- 8 Vss
- 9 Colon control
- 10 50/60 Hz select
- 11 12/24 hour select
- 12 Fast set
- 13 Slow set
- 14 Time set allow
- 15 Seconds display
- 16 Alarm display
- 17 Sleep display
- 18 Alarm off
- 19 Snooze input
- 20 Snooze output
- 21 Sleep output
- 22 Radio supply +
- 23 Radio supply -
- 24 Alarm output
- 25 Speaker output
- 26 Speaker output
- 27 Vdd
- 28 Vdd

**Alarm Clock application**

Mains Transformer Connections

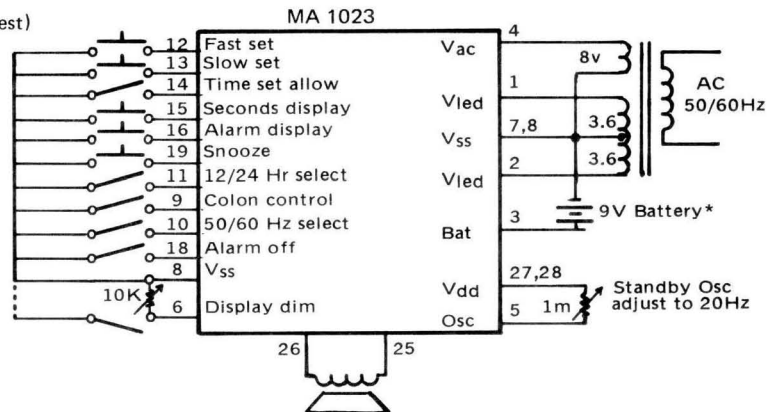
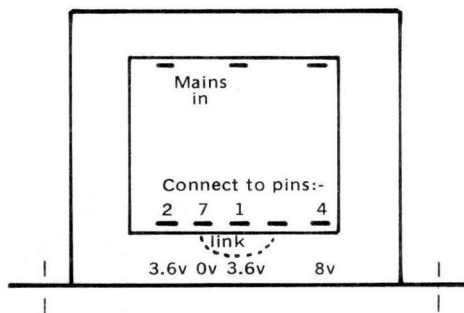

\* Battery and 1 meg standby oscillator adjust optional  
Make no connection to pin 6 for maximum brightness  
Connect pin 10 to V<sub>SS</sub> for U.K.

**Positive supply clock - radio application**

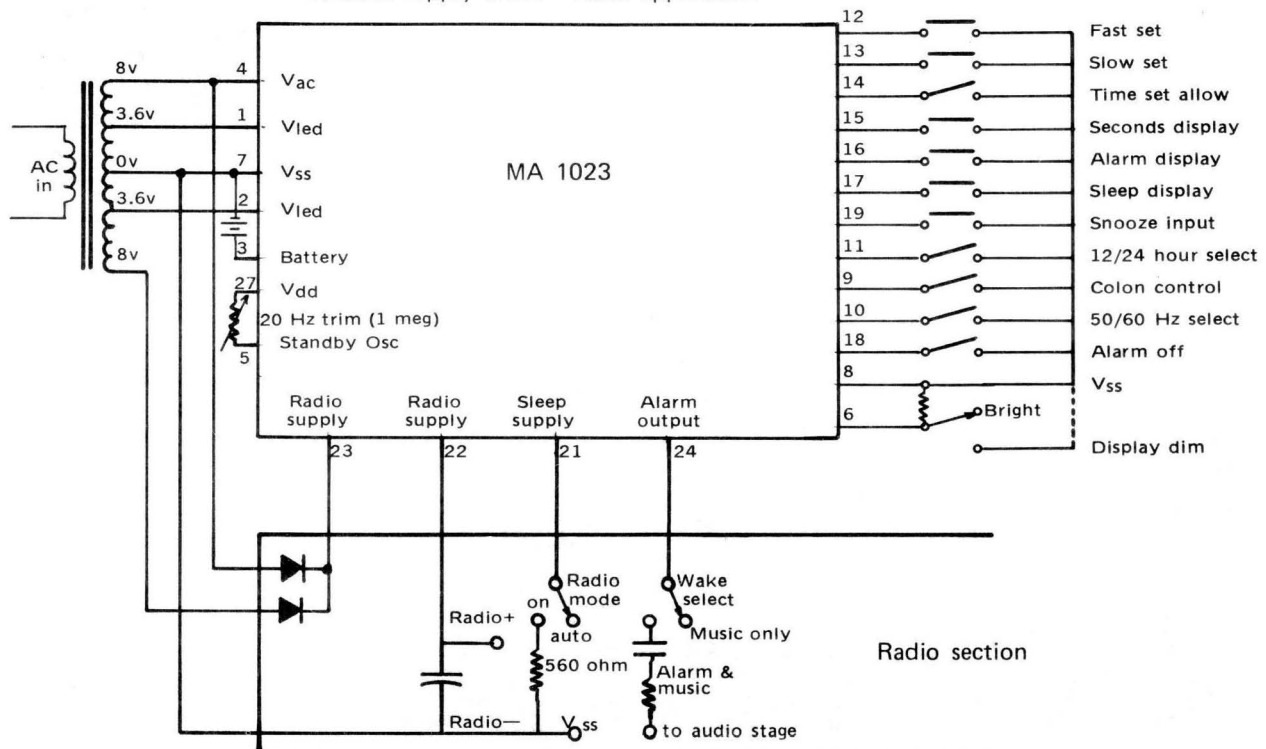

## Car Radio

This superb U.K. built Crusador car radio is supplied with a full installation kit, speaker and a 2 year guarantee. It uses a TBA 810 I.C. in the audio stage and a CA 3123 A.M. Radio I.C. .

### Features

- \* 12 volt dual polarity
- \* Short circuit proof output
- \* 5 push-button tuning (4 Medium, 1 Long-wave)
- \* Over-ride manual control
- \* Illuminated tuning scale
- \* 5 Watt output

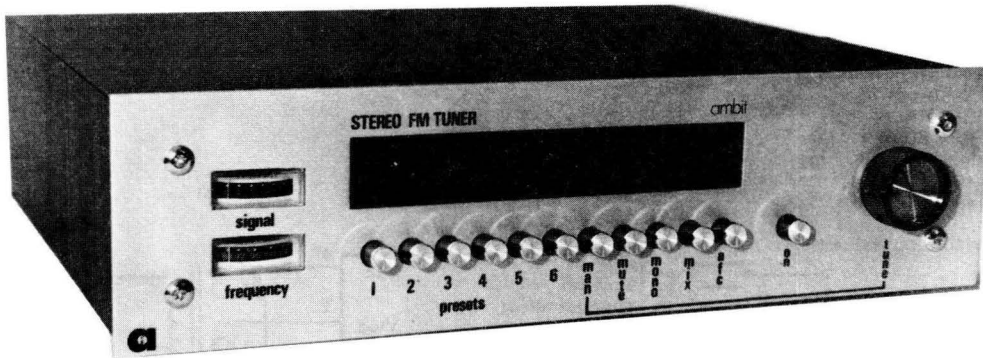
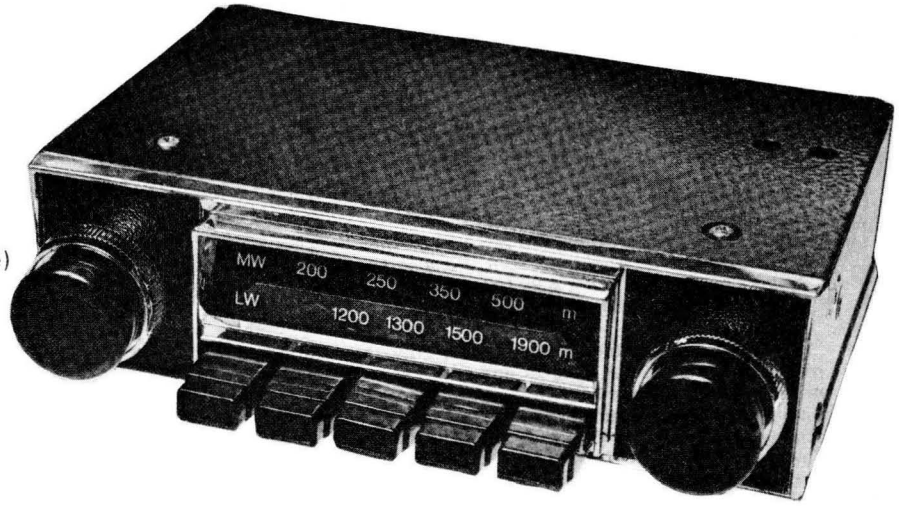

7030 I.F. Module (see page 52)

## International Mk 11

Our own Stereo F.M. Tuner kit (International Mk 11). Uses a Larsholt 7253 tuner module. Contains all the parts to build the high quality tuner pictured above.

### Features

- \* Brushed aluminium front panel, smoked grey visor, walnut vinyl veneer cabinet
- \* 6 preset stations plus manual tune.
- \* Balanced LED tuning indicator
- \* Frequency and signal strength illuminated meters
- \* Mute, Mono, Blend and AFC controls
- \* Pilot tone filter
- \* Adjustable audio output

The kit may also be supplied without the 7253 module but including the PSU, preset board, switches, meters Knobs ect, for the more experienced constructor who may wish to install a different set of modules, such as the 5800 tuner, 7030 I.F. and 91196 decoder.

*n.b. The latest kits have an improved front panel, not as shown in the photograph*

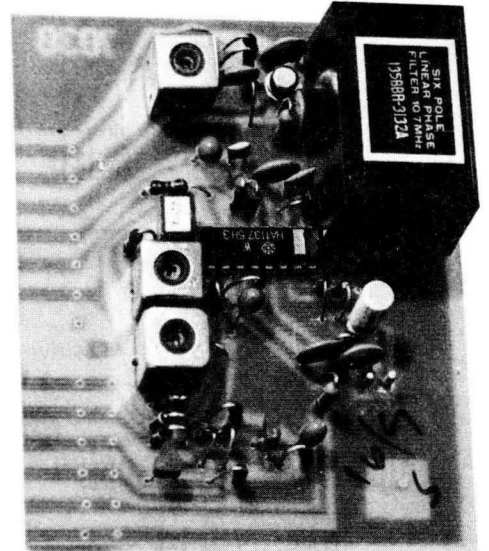

Larsholt Signalmaster Tuner (page 48)  
Very high quality tuner kit, yet can be built in one evening.

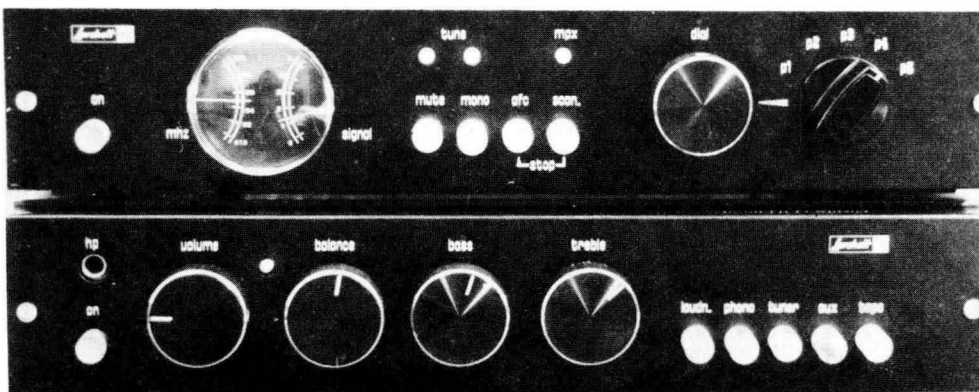

Larsholt Audiomaster Amplifier (page 49)  
Amplifier to match the Signalmaster  
30 Watts R.M.S. per channel.

We present the basic styles of Ex-Stock series, a range of scales is available for each type, details in price list with a separate illustrated leaflet (Customized scales and a wider range of basic styles for OEM customers- details on application)

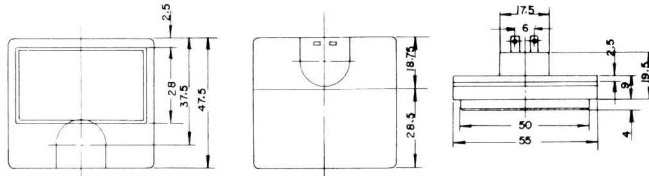
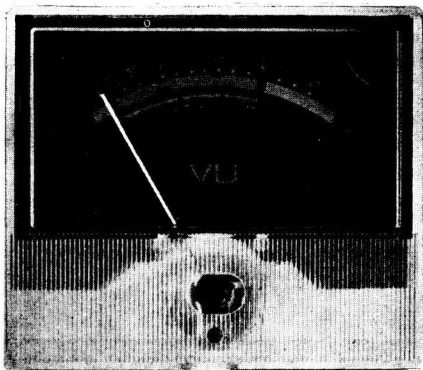

The HS13 series are widely used in recording and tuner applications with mounting either way up. The translucent back permits illumination of scale from behind.

Standard unit 200uA FSD 77uA 50%FSD R 750 ohms  
 Standard scales 'TUNING' 1-5, and VU for back illumination  
 Centre null scaled 0 - 1 - 2 - 3 - 4 - 5 representing 100 - 0 -100uA linear  
 Scale range in leaflet

HS12: 920 series

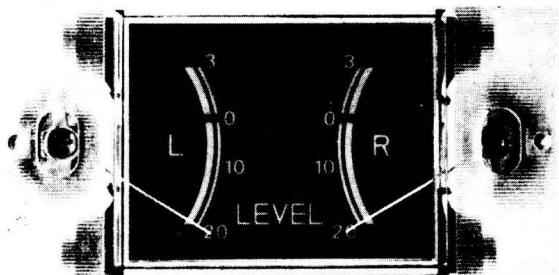

HW15 940 series

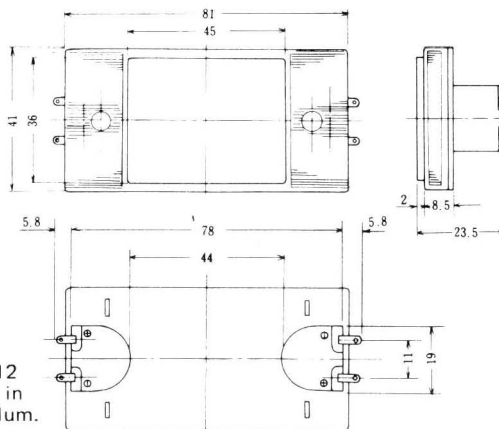

A very low priced double meter, with movement characteristics similar to the HS12. It is possible to combine a centre null function with a left/right biased movement in this style - for example as a combined tuning and signal level meter. OK for rear illum. Standard scales in leaflet 200uA FSD movement R 750 ohms

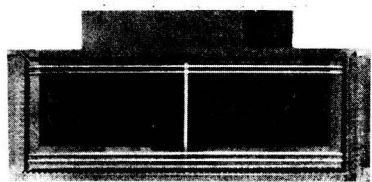

HS12 901 series

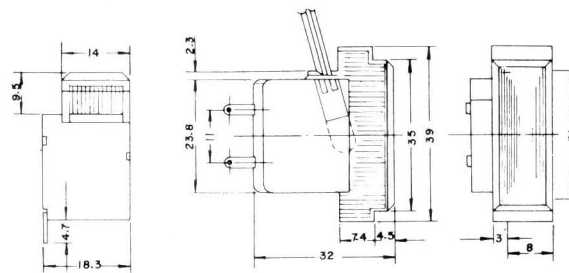

The HS12 is probably one of the most widely used basic styles in equipment today - like the others illustrated here, it is also widely copied by many other sources. Illumination may be provided by an internally mounted bulb (as illustration)

Standard scales in leaflet 200uA FSD, R 750 ohms 77uA at 50% FSD  
 12v 30mA bulb optional (recommended to be run at 10v to prolong life and not glow like a searchlight from your panel!!)

**The HS50 for a touch of class at a bargain price**

The HS50 employs a linear movement - and examination of examples shows linearity to be with 2% overall, which is exceptional for a meter at this price. Illumination is internally provided with a 12v/30mA for lighting from the scale front

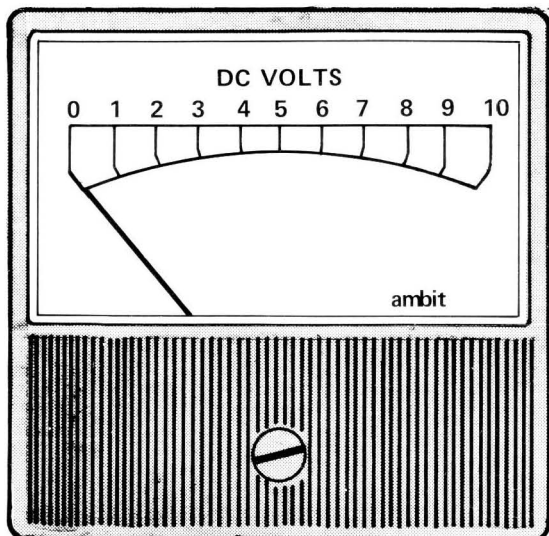

The HS50 - 930 series

The linearity permits ready adaption of this style to applications as current and voltmeters  
 The basic movement: 200uA R: 750 ohms

So to provide 10v FSD, from ohms law use a series R of  $\frac{10}{0.0002} = 50k$  total

The internal R should be subtracted to give 49,750 ohms - not a practical value, so use 47k and 4k7 preset and calibrate from a known reference (multimeter etc)

For a 1mA movement a shunt resistance is used according to ohms law:

$$2.750 = 8.R_{shunt} = \text{current Resistance}$$

$$R_{shunt} = 187.5 \text{ ohms}$$

$$\text{and total 'int. Resistance' = 150 ohms}$$

# ambit international

Coming soon.



How to find us: —

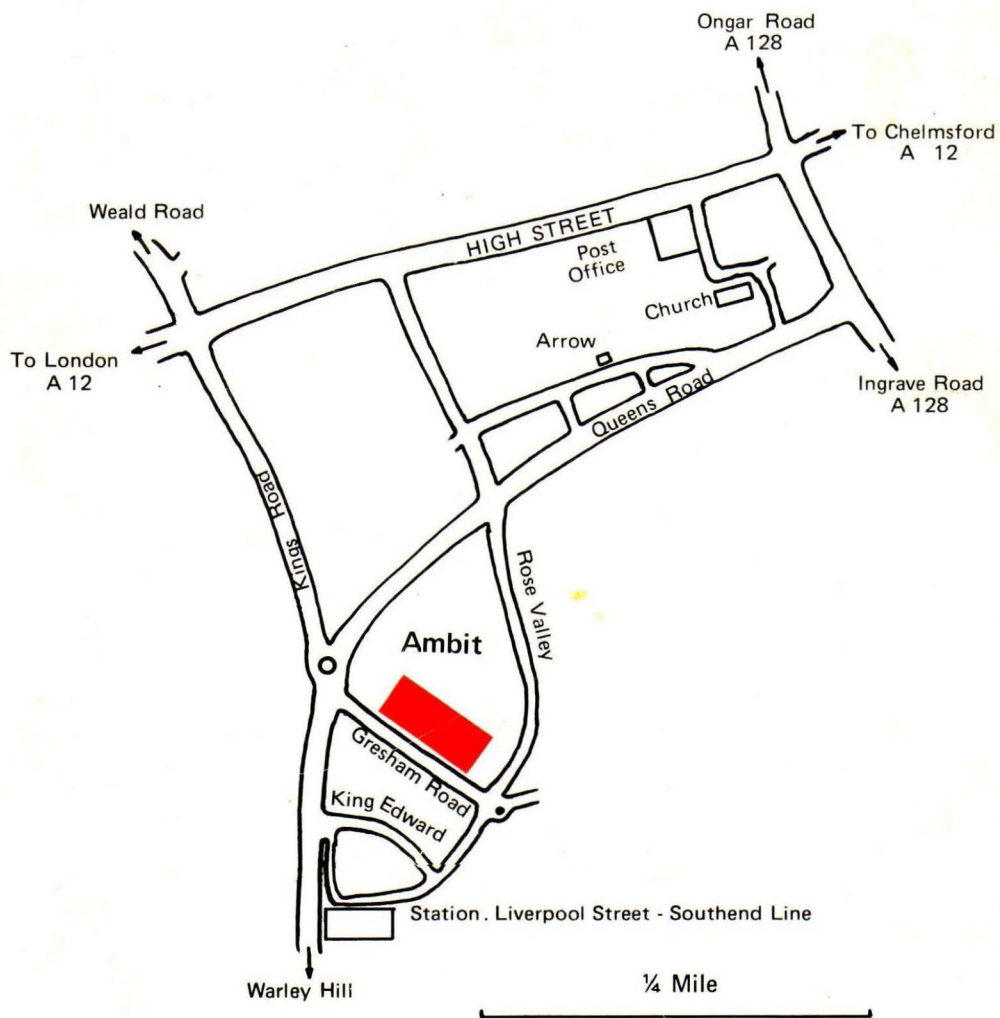

2 Gresham Road, Brentwood, Essex CM14 4HN  
tel. 0277-216029